

Right choice for ultimate yield

LSIS strives to maximize customers' profit in gratitude of choosing us for your partner.

Programmable Logic Controller

RAPIDnet I/F Module

XGT Series

User's Manual

XGL-EIMT	XBL-EIMT
XGL-EIMF	XBL-EIMF
XGL-EIMH	XBL-EIMH
XGL-ES4T	XOL-EIMT
XOL-ES4T	XOL-EIMF



Safety Instructions

- Read this manual carefully before installing, wiring, operating, servicing or inspecting this equipment.
- Keep this manual within easy reach for quick reference.

LSIS

<http://eng.lsis.biz>

Safety Instructions

Before using the product ...

For your safety and effective operation, please read the safety instructions thoroughly before using the product.

- ▶ Safety Instructions should always be observed in order to prevent accident or risk with the safe and proper use the product.
- ▶ Instructions are divided into “Warning” and “Caution”, and the meaning of the terms is as follows.





This symbol indicates the possibility of serious injury or death if some applicable instruction is violated



This symbol indicates the possibility of severe or slight injury, and property damages if some applicable instruction is violated

Moreover, even classified events under its caution category may develop into serious accidents relying on situations. Therefore we strongly advise users to observe all precautions properly just like warnings.

- ▶ The marks displayed on the product and in the user’s manual have the following meanings.
 -  Be careful! Danger may be expected.
 -  Be careful! Electric shock may occur.
- ▶ The user’s manual even after read shall be kept available and accessible to any user of the product.

Safety Instructions

Safety Instructions for design process

Warning

- ▶ **Please install a protection circuit on the exterior of PLC so that the whole system may operate safely regardless of failures from external power or PLC.** Any abnormal output or operation from PLC may cause serious problems to safety in whole system.
 - Install protection units on the exterior of PLC like an interlock circuit that deals with opposite operations such as emergency stop, protection circuit, and forward/reverse rotation or install an interlock circuit that deals with high/low limit under its position controls.
 - If any system error (watch-dog timer error, module installation error, etc.) is detected during CPU operation in PLC, all output signals are designed to be turned off and stopped for safety. However, there are cases when output signals remain active due to device failures in Relay and TR which can't be detected. Thus, you are recommended to install an addition circuit to monitor the output status for those critical outputs which may cause significant problems.

- ▶ **Never overload more than rated current of output module nor allow to have a short circuit.** Over current for a long period time may cause a fire .

- ▶ **Never let the external power of the output circuit to be on earlier than PLC power,** which may cause accidents from abnormal output or operation.

- ▶ **Please install interlock circuits in the sequence program for safe operations in the system when exchange data with PLC or modify operation modes using a computer or other external equipments**
Read specific instructions thoroughly when conducting control operations with PLC.

Safety Instructions

Safety Instructions for design process

Caution

- ▶ **I/O signal or communication line shall be wired at least 100mm away from a high-voltage cable or power line.** Fail to follow this instruction may cause malfunctions from noise

Safety Instructions on installation process

Caution

- ▶ **Use PLC only in the environment specified in PLC manual or general standard of data sheet.** If not, electric shock, fire, abnormal operation of the product may be caused.
- ▶ **Before install or remove the module, be sure PLC power is off.** If not, electric shock or damage on the product may be caused.
- ▶ **Be sure that every module is securely attached after adding a module or an extension connector.** If the product is installed loosely or incorrectly, abnormal operation, error or dropping may be caused. In addition, contact failures under poor cable installation will be causing malfunctions as well.
- ▶ **Be sure that screws get tighten securely under vibrating environments.** Fail to do so will put the product under direct vibrations which will cause electric shock, fire and abnormal operation.
- ▶ **Do not come in contact with conducting parts in each module,** which may cause electric shock, malfunctions or abnormal operation.

Safety Instructions

Safety Instructions for wiring process

Warning

- ▶ **Prior to wiring works, make sure that every power is turned off.** If not, electric shock or damage on the product may be caused.
- ▶ **After wiring process is done, make sure that terminal covers are installed properly before its use.** Fail to install the cover may cause electric shocks.

Caution

- ▶ **Check rated voltages and terminal arrangements in each product prior to its wiring process.** Applying incorrect voltages other than rated voltages and misarrangement among terminals may cause fire or malfunctions.
- ▶ **Secure terminal screws tightly applying with specified torque.** If the screws get loose, short circuit, fire or abnormal operation may be caused. Securing screws too tightly will cause damages to the module or malfunctions, short circuit, and dropping.
- *
 - ▶ **Be sure to earth to the ground using Class 3 wires for FG terminals which is exclusively used for PLC.** If the terminals not grounded correctly, abnormal operation or electric shock may be caused.
 - ▶ **Don't let any foreign materials such as wiring waste inside the module while wiring,** which may cause fire, damage on the product or abnormal operation.
 - ▶ **Make sure that pressed terminals get tighten following the specified torque. External connector type shall be pressed or soldered using proper equipments.**

Safety Instructions

Safety Instructions for test-operation and maintenance

Warning

- ▶ **Don't touch the terminal when powered.** Electric shock or abnormal operation may occur.
- ▶ **Prior to cleaning or tightening the terminal screws, let all the external power off including PLC power.** If not, electric shock or abnormal operation may occur.
- ▶ **Don't let the battery recharged, disassembled, heated, short or soldered.** Heat, explosion or ignition may cause injuries or fire.

Caution

- ▶ **Do not make modifications or disassemble each module.** Fire, electric shock or abnormal operation may occur.
- ▶ **Prior to installing or disassembling the module, let all the external power off including PLC power.** If not, electric shock or abnormal operation may occur.
- ▶ **Keep any wireless equipment such as walkie-talkie or cell phones at least 30cm away from PLC.** If not, abnormal operation may be caused.
- ▶ **When making a modification on programs or using run to modify functions under PLC operations, read and comprehend all contents in the manual fully.** Mismanagement will cause damages to products and accidents.
- ▶ **Avoid any physical impact to the battery and prevent it from dropping as well.** Damages to battery may cause leakage from its fluid. When battery was dropped or exposed under strong impact, never reuse the battery again. Moreover skilled workers are needed when exchanging batteries.

Safety Instructions

Safety Instructions for waste disposal

 **Caution**

- ▶ **Product or battery waste shall be processed as industrial waste.**
The waste may discharge toxic materials or explode itself.

Revision History

Version	Date	Details	Page
V 1.0	'08.01	First Edition	-
V 1.1	'10.03	1. Number of modules available by CPU types (new model added) 2. Specification added	Ch1.3.2 Ch2.2
V 1.2	'10.09	XGB RAPIEnet added	-
V 1.3	'11.05 '11.11	1. How to enable link through flag added 2. XGB RAPIEnet new model (XBL-EIMF/EIMH) added	Ch 5.5.2 -
V 1.4	'13.03	1. Separated text(RAPIEnet, RAPIEnet PC card) 2. Added RAPIEnet PC card for O/S Version Up(V2.0) 3. Added module(XGL-ES4T)	Ch1, 3, 20 Ch15, 16, 17, 18, 19 All Chapter
V 1.5	'14.11	XG5000 V4.0 Tool UI Updated	-
V1.6	'16.12	Added module(XOL-ES4T)	Ch1~4, Appendix

※ The number of User's manual is indicated right part of the back cover.

Copyright © 2013 LSIS Co., Ltd All Rights Reserved.

Thank you for purchasing PLC of LSIS Co.Ltd.

Before use, make sure to carefully read and understand the User's Manual about the functions, performances, installation and programming of the product you purchased in order for correct use and importantly, let the end user and maintenance administrator to be provided with the User's Manual.

The following user's manuals are related with this product.

The User's Manual describes the product. If necessary, you may refer to the following description and order accordingly. In addition, you may connect our website (<http://eng.lsis.biz>) and download the information as a PDF file.

Relevant User's Manuals

Title	Description	Manual number
XG5000 User's Manual (for XGK, XGB)	XG5000 software user manual describing online function such as programming, print, monitoring, debugging by using XGK, XGB CPU	10310000512
XG5000 User's Manual (for XGI, XGR)	XG5000 software user manual describing online function such as programming, print, monitoring, debugging by using XGI, XGR CPU	10310000834
XGK/XGB Instructions & Programming User's Manual	User's manual for programming to explain how to use instructions that are used PLC system with XGK, XGB CPU.	10310000510
XGI/XGR Instructions & Programming User's Manual	User's manual for programming to explain how to use instructions that are used PLC system with XGI, XGR CPU.	10310000833
XGK CPU User's Manual (XGK-CPUA/CPUE/CPUH/CPUS/CPUU)	XGK-CPUA/CPUE/CPUH/CPUS/CPUU user manual describing about XGK CPU module, power module, base, IO module, specification of extension cable and system configuration, EMC standard	10310000508
XGI CPU User's Manual (XGI-CPUU)	XGI-CPUU user manual describing about XGK CPU module, power module, base, IO module, specification of extension cable and system configuration, EMC standard	10310000832
XGR redundant series User's Manual	XGR-CPUU user manual describing about XGR CPU module, power module, extension drive, base, IO module, specification of extension cable and system configuration, EMC standard	10310001059
XGB Hardware User's Manual	XGB Hardware user's manual describing about power, I/O of XGB basic unit, specification of extension, system configuration, specification of high-speed counter	10310000694

RAPiEnet I/F module user's manual has been written based on the following version

[List of relevant product OS version]

Product		OS version(recommend)
XGK/I/R Series	XGK-CPUH, CPUS, CPUA, CPUE, CPUU	V1.7
	XGI-CPUU, CPUH	V2.0
	XGR-CPUH/F, CPUH/T	V1.0
XGB series	XGB Hardware	V2.0
XG5000		V4.10

© Contents ©

Chapter 1 Introduction

1.1 Introduction	1-1
1.2 Features	1-2
1.3 Product Configuration	1-3
1.3.1 Type	1-3
1.3.2 Number of modules available by CPU types	1-3
1.4 Software for Product	1-4
1.4.1 Check point for Software	1-4
1.4.2 XG5000	1-4
1.4.3 Version information	1-5

Chapter 2 Product Specifications

2.1 General Specifications	2-1
2.2 Performance Specifications	2-3
2.2.1 Expectation of Communication Load	2-4
2.3 Structure and Characteristics	2-6
2.4 Cable Specifications	2-10
2.4.1 UTP cable	2-10
2.4.2 Optical cable	2-12

Chapter 3 Installation and Test Operation

3.1 Installation Environment	3-1
3.2 Precaution for Handling	3-6
3.3 Sequence from installation to operation	3-7
3.3.1 RAPIEnet I/F Module for PLC	3-7
3.3.2 RAPIEnet I/F Module for PC	3-8
3.3.3 MRS(XGL-ES4T) I/F Module	3-9
3.3.4 Stand-alone MRS(XOL-ES4T) Module	3-10
3.4 Parameter setting in the XG5000	3-11
3.4.1 Parameter setting	3-11
3.5 I/O Allocation and Device Information	3-12
3.5.1 I/O allocation	3-12

3.6 Installation	3-18
3.6.1 Installation of XGL-EIMT and XOL-EIMT	3-18
3.6.2 Installation of XGL-EIMF and XOL-EIMF	3-20
3.6.3 Installation of XGL-EIMH	3-21
3.6.4 Installation of XGL-ES4T and XOL-ES4T	3-22
3.7 Test Operation	3-23
3.7.1 Precautions for system configuration	3-23

Chapter 4 System Configuration

4.1 Available System Configuration	4-1
4.1.1 Ring type system with electric module	4-1
4.1.2 Ring type system with optical module	4-3
4.1.3 Ring type system with combined module	4-4
4.1.4 Line type system with optical module	4-5
4.1.5 System with MRS module	4-6
4.1.6 System with Stand-alone MRS module	4-7

Chapter 5 Communication Parameters

5.1 Introduction	5-1
5.1.1 High-speed link setting parameters	5-1
5.1.2 P2P Setting Parameters	5-2
5.1.3 Comparison between high speed link and P2P	5-3
5.2 Installation and Execution of Software	5-4
5.2.1 Installation of XG5000	5-4
5.2.2 Installation of USB device driver	5-7
5.2.3 Confirmation of installed USB device drive	5-10
5.3 Registration of Communication Module	5-16
5.3.1 Off-line registration	5-16
5.3.2 On-line registration	5-18
5.3.3 How to read the parameter saved in the PLC	5-19
5.3.4 Module setting method	5-20
5.3.5 Menu bar and shortcut of XG5000	5-21
5.4 How to set the parameter according to service	5-23
5.4.1 High-speed link service	5-23
5.4.2 P2P Service	5-26
5.4.3 MRS parameters setting	5-27
5.5 Operation Start-up	5-28
5.5.1 XG5000 setting	5-28
5.5.2 When operating in high speed link service	5-29
5.5.3 Operating in P2P service	5-35

Chapter 6 High-speed Link

6.1 Introduction	6-1
6.2 HS link Tx/Rx Data Processing	6-2
6.3 Operation Sequence through High-speed Link	6-3
6.4 HS link parameters setting	6-4
6.4.1 HS link parameters setting of XG5000	6-4
6.5 High-speed link information	6-9
6.5.1 High-speed link flag	6-9
6.5.2 Monitor of High-speed link information	6-11

Chapter 7 P2P Service

7.1 Introduction	7-1
7.2 P2P Instruction	7-1
7.3 P2P Application	7-2
7.3.1 Functions and setting of P2P	7-4
7.4 Operation Sequence of P2P Service	7-6
7.5 P2P Service Information	7-7
7.5.1 P2P service from the XG5000 system diagnosis	7-7

Chapter 8 Remote Connection Service

8.1 Introduction	8-1
8.2 Setting and Connection	8-2
8.2.1 Remote 1 connection	8-2
8.2.2 Remote 2 connection	8-5

Chapter 9 Example Program

9.1 High Speed Link Program	9-1
9.1.1 High Speed Link parameter setting	9-1
9.1.2 How to set HS link speed	9-4
9.1.3 High Speed Link Diagnosis service	9-5
9.2 P2P Program	9-6
9.2.1 P2P parameter setting	9-6
9.2.2 P2P Diagnosis	9-10
9.3 MRS setting example	9-11
9.3.1 Communication parameter setting	9-11
9.3.2 Check system operation	9-11

Chapter 10 Diagnostic Function

10.1 System diagnosis	10-1
10.2 Communication module information	10-3
10.2.1 XGL-EIMx	10-3
10.2.2 XGL-ES4T	10-4
10.3 Auto Scan	10-5
10.3.1 Auto scan	10-5
10.3.2 Cable distance measurement	10-7
10.3.3 Diagnosis on the status information of remote modules	10-7
10.4 Media information diagnosis	10-11
10.4.1 Media information	10-11
10.4.2 View error details	10-12
10.5 Troubleshooting	10-13
10.5.1 Diagnosis through communication Module LED	10-13
10.5.2 Diagnosis of Communication Module through XG5000	10-15
10.5.3 Checking module healthiness with system log	10-16

Chapter 11 System Configuration of RAPIenet PC Card

11.1 Installation and Execution of Software	11-1
11.1.1 Installation of RAPIenet-PD	11-1
11.1.2 Menu Information of RAPIenet-PD	11-5
11.2 Basic Settings of RAPIenet-PD	11-6
11.2.1 Basic Settings	11-6

Chapter 12 High-Speed Link of RAPIenet PC Card

12.1 Introduction	12-1
12.2 Driving Sequence by High-Speed Link	12-2
12.3 Setting High-Speed Link Parameter	12-3
12.4 Checking High-Speed Link Action	12-7
12.4.1 Example of Setting Parameter	12-7
12.4.2 Device Monitor	12-7
12.4.3 Comparison between Communication Modules	12-8
12.4.4 Diagnosis function	12-8

Chapter 13 Program Realization of RAPIEnet PC Card

13.1 Introduction	13-1
13.1.1 Realization Sequence of High-Speed Link	13-1
13.1.2 Realization Sequence of P2P Service	13-1
13.2 Program Realization Method	13-2
13.2.1 COM Interface Registration Method	13-2
13.2.2 User Function	13-3
13.3 Performance Measure	13-7

Chapter 14 Example Program of RAPIEnet PC Card

14.1 System Configuration	14-1
14.2 Example Program	14-2
14.2.1 Configuration of Example Program	14-3
14.2.2 High-Speed Link	14-3
14.2.3 P2P	14-3

Chapter 15 Diagnosis Function of RAPIEnet PC Card

15.1 Communication Module Information	15-1
15.2 Auto Scan	15-2
15.3 Media Diagnosis Program	15-3

Appendix

A.1 Terminology	A-1
A.2 List of Flags	A-3
A.2.1 List of Special Relays (F)	A-3
A.2.2 List of Communication Relays (L)	A-11
A.2.3 List of Link device (N)	A-13
A.3 Dimension	A-15
A.4 Troubleshooting	A-19
A.4.1 Hardware failure	A-19
A.4.2 Interface failure	A-20
A.4.3 CPU and interface failure during operation	A-21
A.4.4 High-speed link parameter error	A-22
A.4.5 High-speed link operation failure	A-23
A.5 Performance Table	A-24
A.5.1 High-speed link performance table	A-24
A.6 Error Code	A-25
A.6.1 P2P client error code	A-25
A.6.2 Error Code of RAPIEnet PC Card	A-26
A.7 User Function of RAPIEnet PC Card	A-27
A.7.1 Main Function	A-27
A.7.2 Control Function	A-27
A.7.3 Diagnosis Function	A-28

Chapter 1 Introduction

1.1 Introduction

This User Manual describes the Ethernet RAPIEnet I/F module (hereinafter, RAPIEnet I/F Module) for the exclusive use on dual port in the XGT PLC system network. The RAPIEnet I/F Module carries out the communication between the PLCs in the XGT series on the basis of Ethernet communication, and provides two Ethernet ports which can be configured in line (daisy chain) and ring structure, enabling construction of network which is more flexible than conventional star-type PLC communication module. The RAPIEnet I/F Module can be classified into 2 electrical ports (10/100BASE-TX), 2 optical ports (100BASE-FX), and hybrid (10/100BASE-TX, 100BASE-FX) according to the media type. The Module is an interface module for data transmission between PLCs using these ports.

To create a program, refer to the following manuals together.

- XG5000 user manual
- XGK instruction
- XGK user manual
- XGI/XGR instruction
- XGI/XGR user manual

When configuring communication module system, pay attention to each program and module version.

- 1) When configuring a XGT RAPIEnet I/F module system
 - XGT PLC XG5000 (Programming Tool): V2.0 or above
 - XGK CPU series: V2.0 or above
 - XGI CPU series: V2.0 or above
 - XGR CPU series: V1.0 or above
- 2) When configuring a XGB RAPIEnet I/F module system
 - XGT PLC XG5000 (Programming Tool): V3.3 or above
 - XBC high-end type CPU series: V2.0 or above
- 3) When configuring a MRS(Multiport RAPIEnet Switch) module system
 - XGT PLC XG5000 (Programming Tool): V3.66 or above
 - XGL-EIMx, XOL-EIMx, XBL-EIMx : V2.0 or above
- 4) When configuring a MRS(Multiport RAPIEnet Switch) module system
 - XGT PLC XG5000 (Programming Tool): V4.10 or above
 - XGL-EIMx : V3.1 or above
 - RAPIEnet Smart I/O : V1.1 or above

1.2 Features

The XGT RAPIEnet I/F Nodule has following features.

- (1) Supports IEEE 802.3 Standard.
- (2) Supports high speed link between RAPIEnet modules for high speed data communication.
(Max. 64 blocks for transmission, max. 128 blocks for reception, min. 5ms of high speed link cycle)
- (3) Provides 100BASE-TX and 100BASE-FX media, and supports full duplex of 100Mbps.
- (4) Supports Dynamic Connection/Disconnection using P2P service.
- (5) Suitable for large volume data exchange. (Max. high speed link communication rate: $25,600 * 12 = 307,200$ words)
- (6) Max. 24 modules can be installed per CPU module, available for both principal and extended bases. However, in the XGR system, the module can be installed on the principal base only. The I/F card for PC can be installed 1 per 1 PC.
- (7) Supports ring and line (daisy chain) topology to enable construction of networks most suitable for on-site use. Ring topology structure supports redundancy function.
- (8) Optical, electrical, and hybrid modules are provided for various control networks, overcoming the limitation in distance.
(Built-in switching function enables construction of ring and line topology without additional switch or hub, with reduced wiring and improved flexibility in installation.)
- (9) Provides alarm function for station number conflict.
- (10) Auto Cross-Over function is provided for convenient cable work.
- (11) Cable distance measuring function is provided for the use of electrical cable
- (12) Network-based simultaneous OS upgrade
- (13) Various diagnoses functions are provided. The status information of modules and network is provided.
 - (a) CPU module status
 - (b) Communication module status
 - (c) Communication service (high-speed link, exclusive service, P2P) status
 - (d) Auto Scan function provides the information on the modules belong to the company connected in the network
 - (e) Provides information on the type and data volume of packet received through communication module, which enables network load prediction.
 - (f) Diagnosis of communication modules through network
- (14) Module can be set up simply with station number, without IP

1.3 Product Configuration

1.3.1 Type

It describes product spec. of XGT RAPIEnet I/F module.

Type		Description	Remarks
XGK/I/R	XGL-EIMT	Electric 2 ports	Category 5 or above Multi-mode optical cable of two wires
	XGL-EIMF	Optical 2 ports	
	XGL-EIMH	Electric 1 port, optical 1port	
	XGL-ES4T	Electric 4 ports(RAPIEnet Switch)	
XGB	XBL-EIMT	Electric 2 ports	
	XBL-EIMF	Optical 2 ports	
	XBL-EIMH	Electric 1 port, optical 1port	
Option	XOL-EIMT	Electric 2 ports	
	XOL-EIMF	Optical 2 ports	
Stand-alone	XOL-ES4T	Electric 4 ports(RAPIEnet Switch)	

1.3.2 Number of modules available by CPU types

RAPIEnet I/F Modules can be installed up to 24 sets regardless of main or extension bases. It is recommended to install the modules on the main base for maximum usability. The table below shows the types of services available for each CPU. You can use this table for system construction considering the number of communication modules.

Classification	XGK					XGI				XGR ^{note1)}		XGB	PC I/F Card
	CPUH	CPUH	CPUA	CPUS	CPUE	CPUU	CPUH	CPUS	CPUE	CPUH/F	CPUH/T	XBC	
Max. number of modules using high speed link	12									6 ^{note2)}		2	5
Max. number of modules using P2P	8									6 ^{note2)}		2	-
Max. number of module (including the modules using exclusive services)	24									6 ^{note2)}		2	5

Note

Note1) Installation position of RAPIEnet I/F module according to CPU type

- When using XGK/XGI CPU, you can install the RAPIEnet I/F module at main both base and expansion base.

- When using XGR CPU, you can install the RAPIEnet I/F module at main base only.

Note2) The number of XGR's module using P2P

- For RAPIEnet, it can be installed at main base so the number of module using High speed link and P2P is up to 6.

Note3) XOL-ES4T can mount Basic base and extension base in XGK/XGI system(Can mount 1 module per base)

But, MRS can mount Extension base in XGR system.

1.4 Software for Product

It describes major programming tool and other developer's software for using XGT RAPIEnet I/F module. For more accurate application of program and communication, it is useful to refer to the follows before applying to the system.

1.4.1 Check point for Software

Category	Item	Communication setting
XGL-EIMT	Comm. Module for XGT	XG5000
XGL-EIMF		
XGL-EIMH		
XBL-EIMT		
XBL-EIMF		
XBL-EIMH		
XGL-ES4T		
XOL-ES4T		
XOL-EIMT	PCI interface hardware	User application, RAPIEnet-PD
XOL-EIMF	Device driver (*.DLL)	(Visual basic, Visual C etc.)

Note

1) The above program is downloadable from the website below. If Internet is not available, it is also possible to use it from Installation CD-ROM by visiting the close agency.

Internet Website: <http://www.lsis.biz>

2) XG5000 is programmable through RS-232C port of CPU module and USB. For the cable type, refer to XGT Catalog Product Exhibit(USB-301A, K1C-050A).

1.4.2 XG5000

XG5000 is the dedicated communication software supporting basic parameter setting, frame creation and diagnostics of module and network for the operation of all communication modules including RAPIEnet I/F module.

The following figure shows the initial window when starting XG5000.

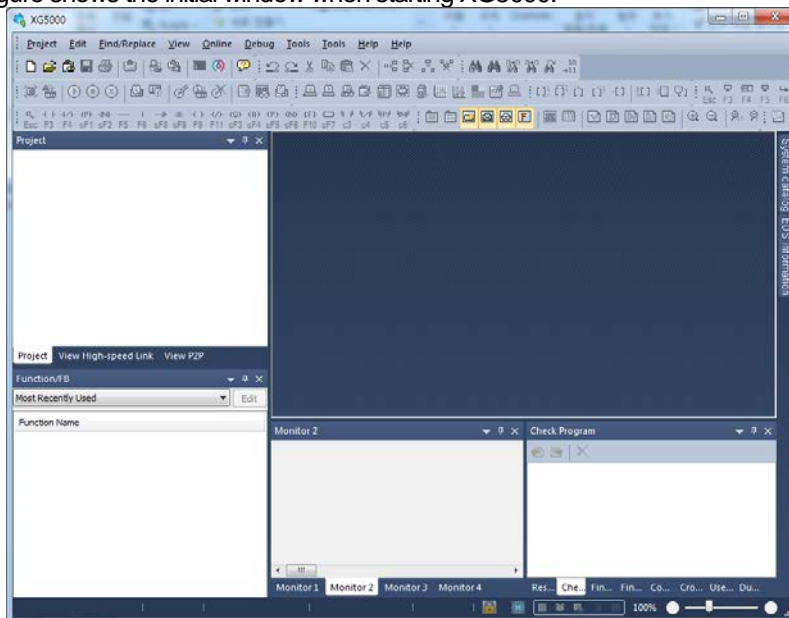

[Fig. 1.4.1] XG5000 Initial Window

1.4.3 Version information

Before using RAPIE I/F module, MRS module, check the version of module.

(1) Check by XG5000

It directly connects communication module online to read the info of communication module. During normal interface with CPU, it can show the following information.

- (a) Run XG5000.
- (b) With online connection, connect to CPU.
- (c) If connected to CPU, it executes System Diagnosis of XG5000.
- (d) In the system diagnosis window from the [online]-[Communication module setting] menu, place the mouse pointer on the pertinent communication module.
- (e) Double-click the communication module, or right-click the mouse button. Select detail information of the communication module.

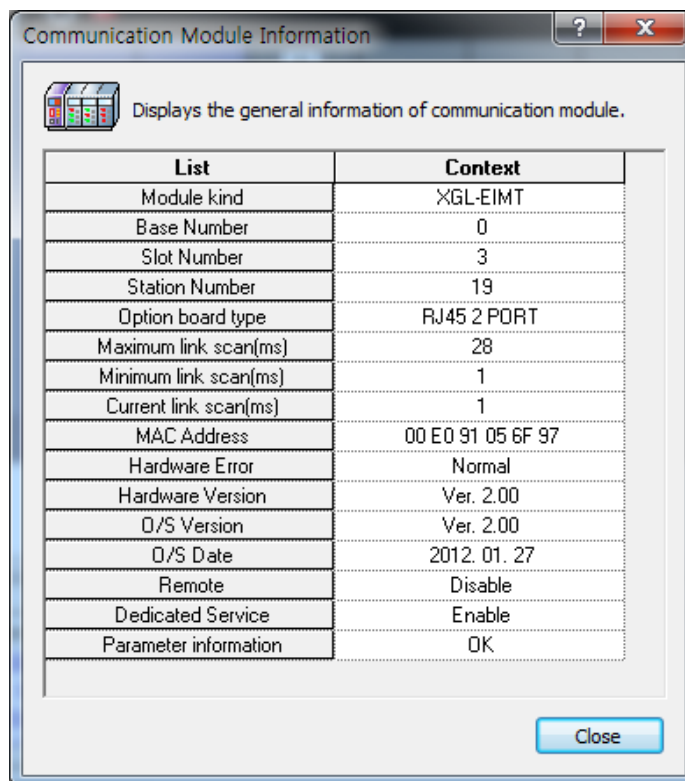

[Fig. 1.4.2] Checking module's version by XG5000

(2) Check by product's case label

Each communication module is with module's product info on its external case.

If online check is not possible due to absence of any external device interfacing with a PC, it can be checked after detaching a module.

The rear side has product label showing the product's type and version.

Chapter 2 Product Specifications

2.1 General Specifications

General specifications of XGT series are as shown below.

No.	Items	Specifications	Related standards			
1	Operating temperature	0 ~ 55 °C				
2	Storage temperature	-25 ~ +70 °C				
3	Operating humidity	5 ~ 95%RH (Non-condensing)				
4	Storage humidity	5 ~ 95%RH (Non-condensing)				
5	Vibration resistance	Occasional vibration			-	IEC61131-2
		Frequency	Acceleration	Amplitude	times	
		$5 \leq f < 8.4\text{Hz}$	-	3.5mm	10 times each directions (X, Y and Z)	
		$8.4 \leq f \leq 150\text{Hz}$	$9.8\text{m/s}^2(1\text{G})$	-		
		Continuous vibration				
		Frequency	Acceleration	Amplitude		
		$5 \leq f < 8.4\text{Hz}$	-	1.75mm		
$8.4 \leq f \leq 150\text{Hz}$	$4.9\text{m/s}^2(0.5\text{G})$	-				
6	Shock resistance	<ul style="list-style-type: none"> • Peak acceleration: $147\text{ m/s}^2(15\text{G})$ • Duration: 11ms • Half-sine, 3 times each direction per each axis 	IEC61131-2			
7	Noise resistance	Square wave Impulse noise	AC: $\pm 1,500\text{ V}$ DC: $\pm 900\text{ V}$	LSIS standard		
		Electrostatic discharge	4.0kV (Contact discharge)	IEC61131-2 IEC61000-4-2		
		Radiated electromagnetic field noise	80 ~ 1,000 MHz, 10V/m	IEC61131-2, IEC61000-4-3		
		Fast transient/bust noise	Segment Voltage	Power supply module 2kV	Digital/analog input/output communication interface 1kV	IEC61131-2 IEC61000-4-4
8	Environment	Free from corrosive gasses and excessive dust				
9	Altitude	Up to 2,000 ms				
10	Pollution degree	2 or less				
11	Cooling	Air-cooling				

[Table 2.1.1] General specification for PLC

Chapter 2 Product Specifications

General specifications of PC I.F card are as shown below.

No.	Items	Specification	Reference
1	Ambient Temp.	0°C ~ +55°C	
2	Storage Temp.	-25°C ~ +70°C	
3	Ambient humidity	5 ~ 95%RH, (Non-condensing)	
4	Storage humidity	5 ~ 95%RH, (Non-condensing)	
5	Noise Immunity	Square wave impulse noise	AC: ±1,500V DC: ±900V LSIS internal test spec.
		Electrostatic discharge	4.0kV (Contact discharge) IEC 61131-2, IEC 61000-4-2
		Radiated electromagnetic field noise	80 ~ 1,000MHz, 10 V/m IEC 61131-2, IEC 61000-4-3
6	Operation ambience	Free from corrosive gases and excessive dust	
7	Altitude	Less than 2,000m	
8	Pollution degree	Less than 2	
9	Cooling method	Air-cooling	

[Table2.1.2]General specification for PC I/F card

Notes

1) IEC (International Electrotechnical Commission):

An international nongovernmental organization which promotes internationally cooperated standardization in electric/electronic field, publishes international standards and manages applicable estimation system related with.

2) Pollution degree:

An index indicating pollution degree of the operating environment which decides insulation performance of the devices. For instance, Pollution degree 2 indicates the state generally that only non-conductive pollution occurs. However, this state contains temporary conduction due to dew produced.

2.2 Performance Specifications

Specifications for system configuration are as described below according to media of RAPIEnet I/F module. Refer to the table below for system configuration.

Item		XGK/I/R		XGB		Stand-alone		
		100BASE-FX	100BASE-TX	100BASE-FX	100BASE-TX	100BASE-FX	1000BASE-TX	
Transmission Specification	Baud rate	100Mbps	100Mbps	100Mbps	100Mbps	100Mbps (1, 2 Ch)	100M/1Gbps (3, 4 Ch)	
	Transmission Type	Base band						
	Max. extended length between nodes	2km	100m	2km	100m	100m		
	Max. number of nodes	64						
	Max. protocol size	1,516 byte						
	Access method to service zone	CSMA/CD						
	Frame error check	CRC 32 = $X^{32} + X^{26} + X^{23} + \dots + X^2 + X + 1$						
	Max. equipment no. <small>note1)</small>	PLC	24		2		-	
		PC	1		-	-	-	
		Stand-alone	-		-	-	1 (per network)	
	Equip-able location	P L C	XGK-CPUU/H, XGI-CPUU	Main base-extension step 7	-	-	-	
			XGK-CPUE	Main base-extension step 1	-	-	-	
			XGK-CPUA/S, XGI-CPUH/S	Main base-extension step 3	-	-	-	
			XGR-CPUH/F, XGR-CPUH/T	Main base	-	-	-	
XBC			-	Main base extension		-		
PC			Empty PCI slot	-	-	-		
Normal communication guarantee		Max. 3,600(packet/sec) <small>note2)</small>		Max. 1,200 (packet/sec) <small>note3)</small>		Max. 3,600(packet/sec) <small>note2)</small>		
Basic Specification	Dimension (mm)	PLC	98(H) X 27(W) X 90(D)	90(H) X 27(W) X 63(D)		112.8(H) X 36(W) X 112(D)		
		PC	18(H) X 120(W) X 174(D)	-	-			
	Consumption current (mA)	PLC	Electric: 330, Optical: 670, Combined: 510, MRS: 796		Electric: 280, Optical: 670, Combined: 480		300	
		PC	Electric: 630, Optical: 630		-	-		
	Weight (g)	PLC	Electric: 102, Optical: 109, Combined: 105, MRS: 104		Electric: 78, Optical: 98, Combined: 95		140	
		PC	Electric: 104, Optical: 128,		-	-		

[Table 2.2] Performance Specifications

Notes

- 1) For XGR, you can install up to 6 at PLC. But, MRS(XGL-ES4T) Can mount 1 module per base
- 2) Normal communication guarantee means the amount of maximum RX packet that guarantees normal communication when using RAPIEnet I/F module. If the amount of maximum RX packet is exceeded, communication, system monitoring and remote connection service may be abnormal.
 - ▶ The amount of packet is applied to only High Speed Link communication.
 - ▶ The amount of packet of normal communication guarantee is applied to only RX.
- 3) For XGB, data size per sec is maximum 10Kbyte/sec. If there are more TRX data, communication may not be normally conducted. So adjust your network load.
- 4) When starting the initial communication, 2~3 sec is needed to check the connected module. During initialization, communication may not be normally conducted.

2.2.1 Expectation of Communication Load

Communication load is classified into load by media interrupt received every second on RAPIEnet media and TX load (load by Link I/F) transmitted by CPU module to RAPIEnet. In case the guarantee amount of load by media interrupt and TX load is exceeded, data communication, system monitoring and remote connection may be abnormal.

(1) Communication load by media interrupt

- ▶ Load by the frame coming from the media
- ▶ Determines the amount of load according to packet per second
- ▶ Max load of RAPIEnet module by media interrupt: about 3600 packet/sec
- ▶ How to check: XG5000 → online → Communication module setting → system diagnosis → media information → Broadcast (RX) monitoring

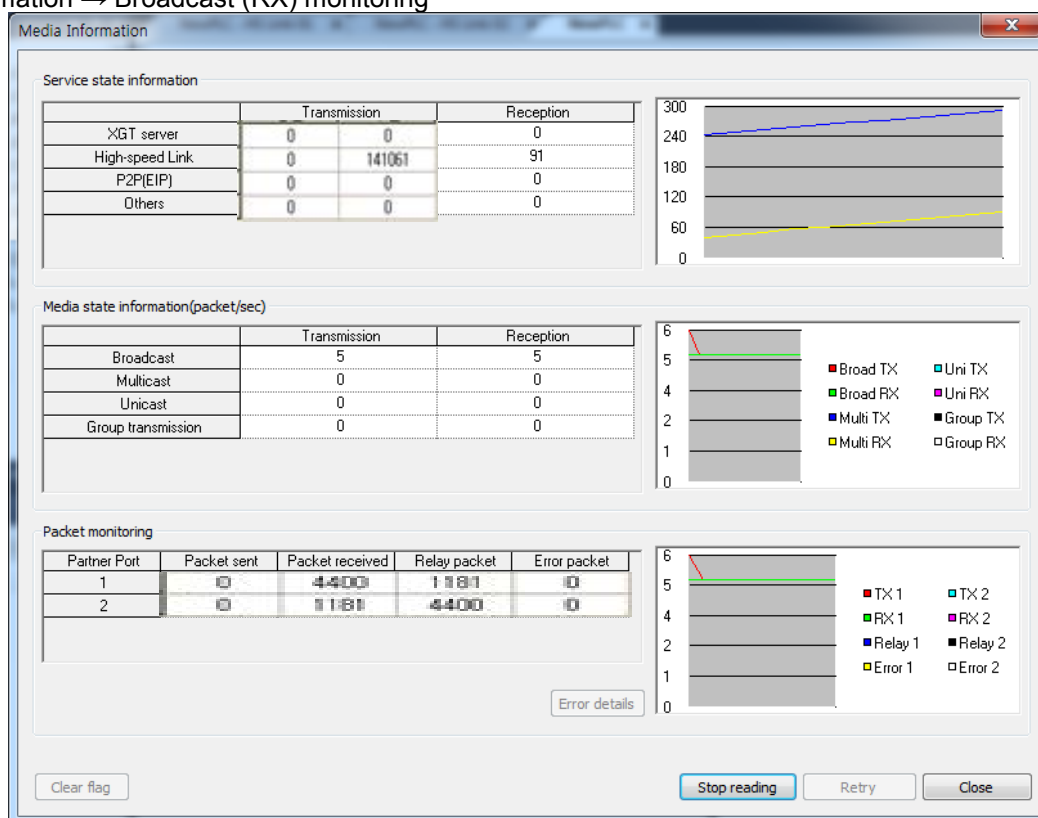

- ▶ When the maximum amount of load is exceeded, RAPIEnet operates abnormally:
Abnormal communication, diagnosis unavailable, remote connection unavailable and etc.
- ▶ Though RX block is not set in High Speed link parameter; media interrupt can occur and affect the load.
- ▶ Measure in case of exceeding the maximum amount of load: increase the communication period. Ex) 20ms → 100ms

(2) XGK/I/R system's TX load (load by Link I/F interrupt)

- ▶ Load by the data transmitted by CPU module to communication module
- ▶ Determines the amount of load according to link scan time of CPU module and High Speed Link service period
- ▶ How to calculate the maximum number of high speed link block available to transmit based on link I/F interrupt:

$$((\text{TX period}/\text{CPU max. scan time}) \times 8\text{block}) / 2 = \text{No. of max. TX block}$$
- ▶ Measure when max. TRX load is exceeded: increase TX period of RAPIEnet module and change the number of block
- ▶ The max number of TX block considering CPU scan time and High Speed Link communication period

HS link Comm. Period (ms)	CPU scan time (ms)	Max. no. of TX block	Time to process TX frame (ms)
5	5 or less	4	2
	Over 5	No guarantee	-
10	5 or less	8	4
	10 or less	4	2
	Over 10	No guarantee	-
20	5 or less	16	8
	10 less	8	4
	20 or less	4	2
	Over 20	No guarantee	-
50	5 or less	32	16
	10 or less	16	8
	20 or less	8	4
	50 or less	4	2
	Over 50	No guarantee	-
100	5 or less	64	32
	10 or less	32	16
	20 or less	16	8
	50 or less	8	4
	100 or less	4	2
	Over 100	No guarantee	-
200	10 or less	64	32
	20 or less	32	16
	50 or less	16	8
	100 or less	8	4
	200 or less	4	2
	Over 200	No guarantee	-
500	20 or less	64	32
	50 or less	32	16
	100 or less	16	8
	200 or less	8	4
	500 or less	4	2
	Over 500	No guarantee	-
1000	50 or less	64	32
	100 or less	32	16
	200 or less	16	8
	500 or less	8	4
	Over 500	No guarantee	-

2.3 Structure and Characteristics

Names of each part of module for PLC are as follows

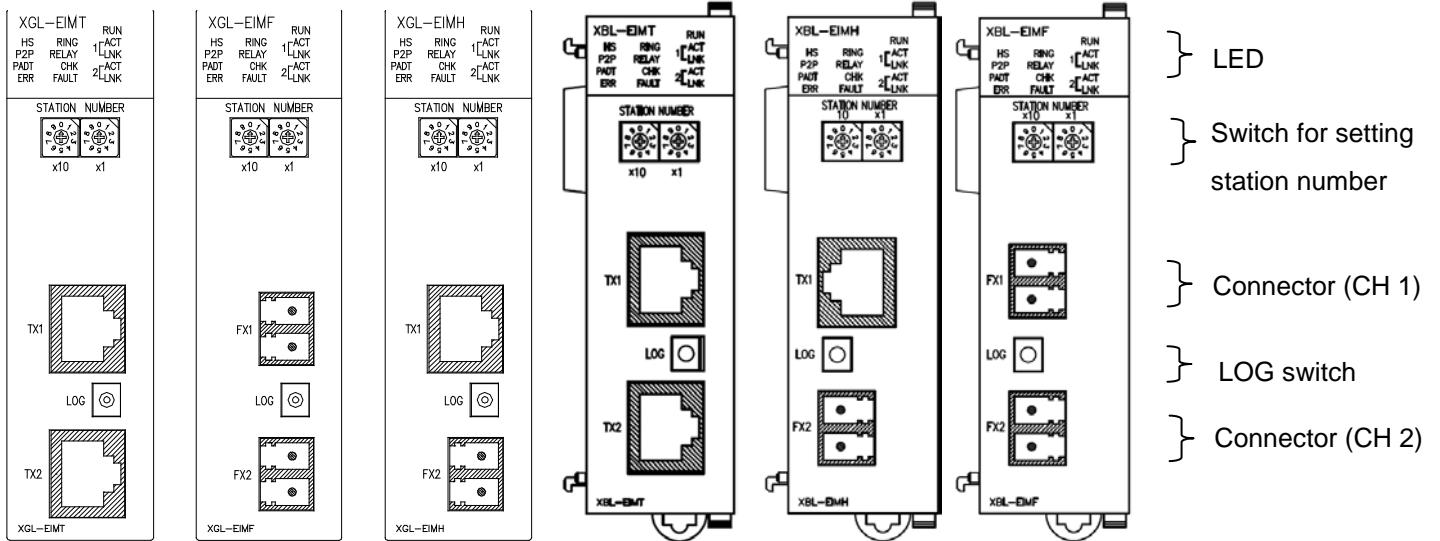

[Fig. 2.3.1] Front part of I/F module for PLC

<LED name and details>

LED	Status	Details
RUN	ON	Power on and CPU normal
	OFF	Power off and CPU abnormal
HS (High Speed)	ON	High speed link is set
	OFF	High speed link is not set
P2P	ON	P2P service is set
	OFF	P2P service is not set
PADT	ON	XG5000 remote connecting
	OFF	XG5000 remote connection cancel
RING	ON	Ring network
	Flicker	Change from Ring to Line
	OFF	Line network
RELAY	ON	In case of Frame relay
LNK	ON	Network link configuration
ACT	Flicker	Send/receive frame
CHK	ON	There are duplicated modules in the same network
	Flicker	Alarm for the Receive packet over 3,500(only XGL-EIMx)
FAULT	ON	There is module whose station number is same with this module
ERR	ON	H/W error

Note

- 1) When using switch for setting station number, please use the precision screwdriver of 1~2mm.
- 2) If switch for setting station number placed in the incorrect position, station may be set incorrectly.

Names of each part of module for PC are as follows

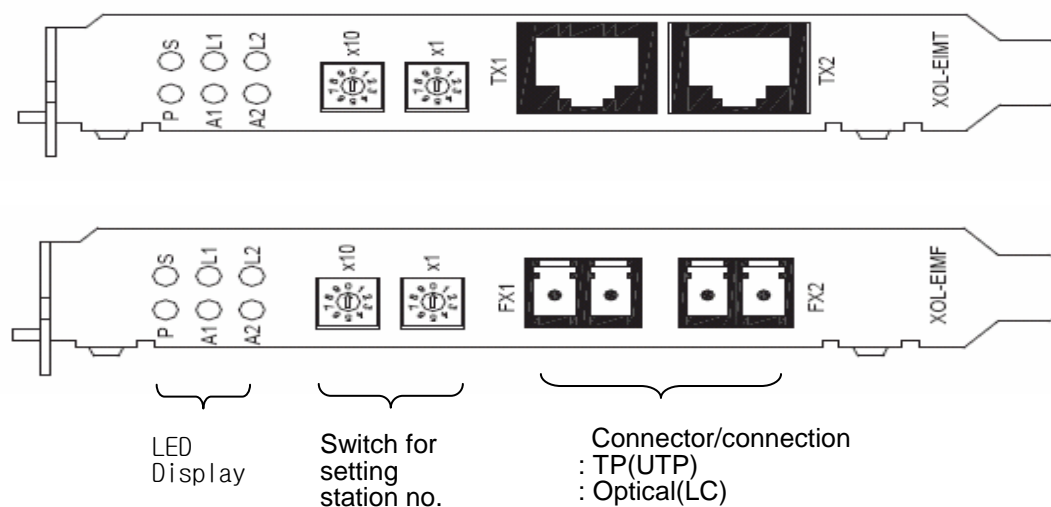

[Fig. 2.3.2] Front part of I/F module for PC

<LED name and details>

LED	Status	Details
P (Power)	ON	Power on
	OFF	Power on or power part abnormal
S (Status)	ON	CPU normal
	OFF	CPU abnormal
L1 (Link 1)	ON	CH1 network link configuration
A1 (ACT 1)	Flicker	CH1 send/receive frame
L2 (Link2)	ON	CH2 network link configuration
A2 (ACT 2)	Flicker	CH2 send/receive frame

Note

- 1) When using switch for setting station number, please use the precision screwdriver of 1~2mm.
- 2) If switch for setting station number placed in the incorrect position, station may be set incorrectly.

Names of each part of module for XGL-ES4T MRS is as follows

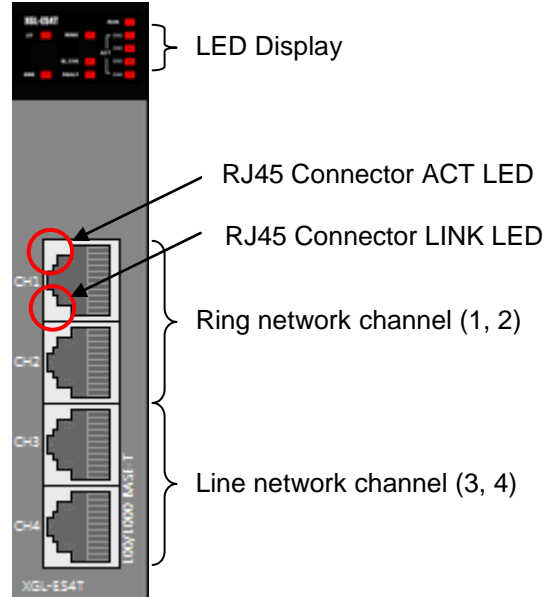

[Fig 2.3.3] Front part of MRS

<LED Status for MRS>

Silk	LED Status	Contents
RUN	On	Power On and module initialization is complete
	Off	Power Off and module initialization error
I/F	Flicker	MRS and CPU Interface is OK
	On/Off	MRS and CPU Interface isn't OK
RING	On	Channel 1,2 Ring topology
	Flicker	After channel 1, 2 is Ring topology, It is changed Line topology.
	Off	When power on, Channel 1,2 is Line topology.
M_CHK	On	When module has warning(Ex. Station conflict)
	Off	No warning
ERR	On	When module has error(Ex, Station conflict)
	Off	No error
FAULT	On	When H/W has Error(EX. Memory error)
	Off	Normal state
CHK	On	When CRC Err on the port occurred, Error resolved after lights out
	Flicker	Port data exceeded
	Off	Normal
ACT	Flicker	When each port is sending and receiving (RJ45 Connector LED)
LINK	On	When each port is connected(RJ Connector LED)

Note

- 1) When using switch for setting station number, please use the precision screwdriver of 1~2mm.
- 2) If switch for setting station number placed in the incorrect position, station may be set incorrectly.

Names of each part of module for XOL-ES4T Stand-alone MRS is as follows

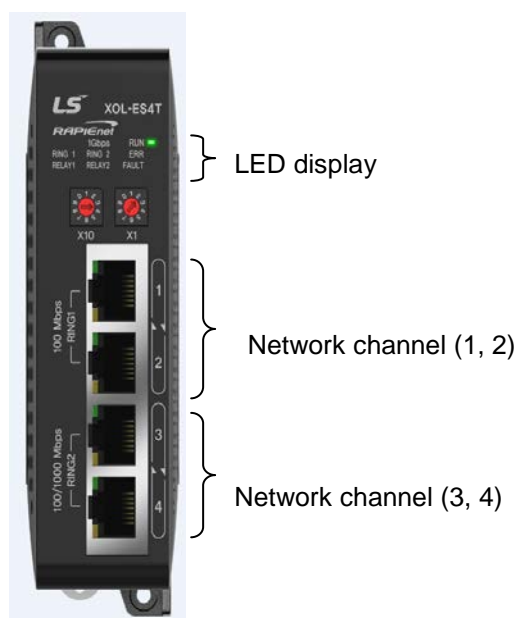

[Fig 2.3.4] Front part of Stand-alone MRS

<LED Status for Stand-alone MRS>

Silk	LED Status	Contents
RUN	On	Power On and module initialization is complete
	Off	Power Off and module initialization error
RING1	On	Channel 1, 2 Ring topology
	Flicker	After channel 1, 2 is Ring topology, It is changed Line topology.
	Off	When power on, Channel 1, 2 is Line topology.
RING2	On	Channel 3, 4 Ring topology
	Flicker	After channel 3, 4 is Ring topology, It is changed Line topology.
	Off	When power on, Channel 3, 4 is Line topology.
RELAY1	On	Channel 1, 2 when frames are relayed
RELAY2	On	Channel 3, 4 when frames are relayed
FAULT	On	When module has error(Ex, Station conflict)
	Off	Normal state
ERR	On	When H/W has Error(EX. Memory error)
	Off	No error
1Gbps	On	When Channel 3, 4 are 1Gbps connection
	Off	When Channel 3, 4 are 100Mbps connection

2.4 Cable Specifications

2.4.1 UTP cable

UTP cable is classified into 3 types based on the following criteria.

- Shield: classified into 3 (UTP, FTP, STP)
- Frequency band used: classified into 7 (Cat.1~7)
- Fire: classified into 4(CMX, CM, CMR, CMP)

(1) Type of cables (shield)

Classification	Details	Purpose
UTP (or U.UTP)	Unshielded cable. High speed data transmission.	Max. 200MHz Phonetic+Data+Low grade of video signal
FTP (or S.UTP)	Shielded cable core only.	Max.100MHz Electronic impediment (EMI) and electric stability considered Phonetic+Data+Low grade of video signal
STP (or S.STP)	Double-shielded cable. Shielded core and Individually Pair cable	Max. 500MHz Phonetic+Data+Video signal Substitute for 75Ω coaxial cable

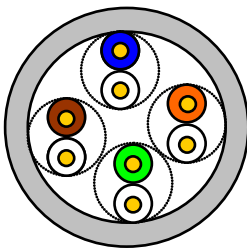

UTP

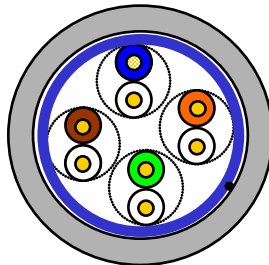

FTP

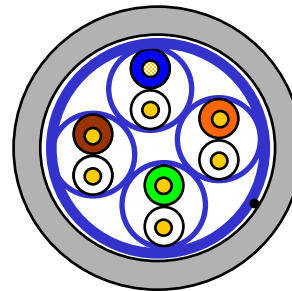

STP

Notes

1) UTP : Unshielded Twisted Paired Copper Cable

FTP : (Overall) Foiled Twisted Paired Copper Cable

STP : (Overall) Shielded(and Shielded Individually Pair)Twisted Paired Copper Cable

2) Patch Cable(or Patch Cord)

Conductor composed of stranded cable instead of solid conductor may be used to increase the flexibility of UTP 4-pair cable. And surface specification and materials used is Un-coated AWG 24 (7/0203A).

In other words, the diameter of a single cable is 0.203mm, and this cable is of 1+6 structure as standardized with annealed copper cable.

3) When Stabilize EMI or electric noise, Please use EMI core or use STP, FTP cable.

(2) Classification based on frequency used

Classification	Frequency used (MHz)	Transmission Speed (Mbps)	Purpose
Category 1	Phonetic Frequency	1	Phone network (2-Pair)
Category 2	4	4	Multi-Pair communication cable
Category 3	16	16	Phone network + Computer network
Category 4	20	20	1) Computer network transmission speed Up 2) Low-loss communication cable
Category 5 and Enhanced Category 5	100	100	1) Digital Phone network + Computer network 2) Low-loss, broadband cable

Notes

- 1) Presently classified items are Category 3, 5, En-Cat.5 and Cat.6 inside and outside of the country, where Category 4 has been replaced by Category 5 and Category 7 is being under development all over the world as STP structure.

(3) Classification based on fire (UL standard)

Classification	Heat	Time	Length of fire	Smoke suppression	Reference
CMP	88(kW)	20 min	73m or less	Restriction	<ul style="list-style-type: none"> • For ceiling without duct • High voltage (Plenum) cable • UL 910 (Plenum test)
CMR	150(kW)	30 min	3.6m or less	Non-Restriction	<ul style="list-style-type: none"> • Vertical installation • Non high voltage (Non-Plenum) cable • UL 1666(Riser test)
CM	21(kW)	20 min	2.4m or less	Non-Restriction	<ul style="list-style-type: none"> • Standard type • Non high voltage (Non-Plenum) cable • UL 1581(VTFT test)
CMX	1(kW)	1 min	0.5m or less	Non-Restriction	<ul style="list-style-type: none"> • Restriction use • Non high voltage (Non-Plenum) cable • UL 1581 (VW-1 test)

Notes

- 1) Though there is CMG between CM and CMR level, that is not applied to LAN cable such as UTP cable
 Ex) CMG: it is CAS FT4 (VTFT test) and similar with CM
 →Sample condition (1/2 interval array → 6 bundles x 6) is different with that of Burner angle (horizontal→45degrees upward)

(4) Example (CTP-LAN5) of Category 5 twisted-pair cable (UTP)

Item	Unit	Value	
Conductor resistance(Max)	Ω /km	93.5	
Insulation resistance(Min)	M Ω ·km	2,500	
Voltage endurance	V/min	AC 500	
Characteristic impedance	Ω (1~100MHz)	100 \pm 15	
Attenuation	dB/100m or less	10MHz	6.5
		16MHz	8.2
		20MHz	9.3
Near-end crosstalk Attenuation	dB/100m or less	10MHz	47
		16MHz	44
		20MHz	42

2.4.2 Optical cable

Item	Value
Cable Type	Twin strands of multi-mode fiber optic cable(MMF)
Connector	SC type connector
Diameter of optical fiber	62.5/125 μ m (62.5 μ m fiber optic core and 125 μ m outer cladding)
Wavelength used	1,350 nm
Attenuation	2dB/1,000m or less
Near-end crosstalk Attenuation	11dB or less

Notes

- 1) Since the type of the connectable cable used for communication module differs from each other based on the system configuration and its environment, applicable professional advice will be required prior to installation.
- 2) The optical cable may have communication errors due to attenuation if any fingerprint or contamination is stuck on the sectional end of the cable during its treatment.

Chapter 3 Installation and Test Operation

3.1 Installation Environment

This product is of high reliance regardless of installation environment. However, for the sake of reliance and stability of the system, please pay attention to those precautions described below.

(1) Environmental Conditions

- (a) To be installed on the control panel waterproof and dustproof.
- (b) No continuous impact or vibration shall be expected.
- (c) Not to be exposed to the direct sunlight.
- (d) No dew shall be caused by rapid temperature change.
- (e) Ambient temperature shall be kept 0-55°C.

(2) Installation Work

- (a) No wiring waste is allowed inside PLC when wiring or drilling screw holes.
- (b) To be installed on a good location to work on.
- (c) Don't let it installed on the same panel as a high-voltage device is on.
- (d) Let it kept at least 50 mm away from duct or near-by module.
- (e) To be grounded in an agreeable place free from noise.

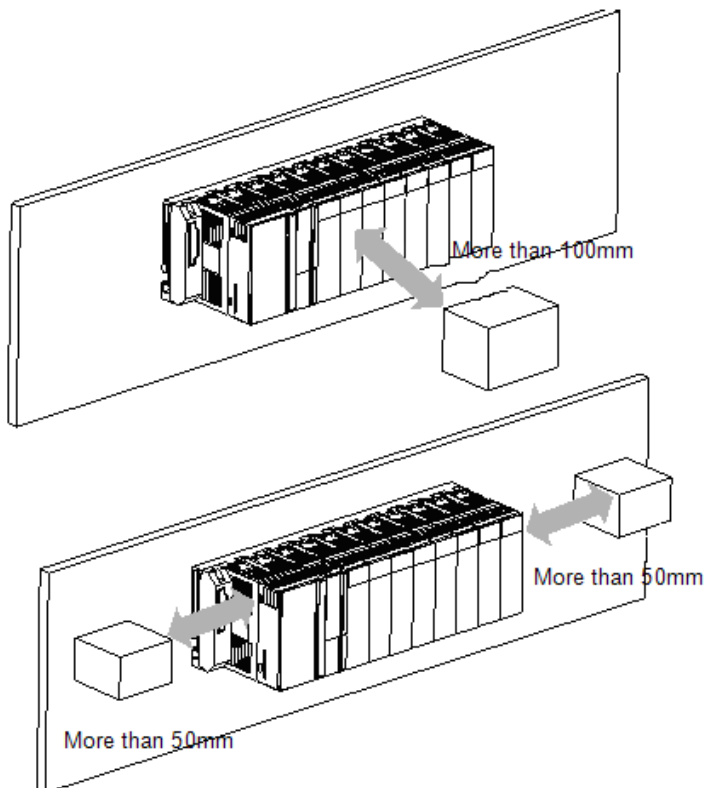

Chapter 3 Installation and Test Operation

(3) Equipment of XGB module

- (a) Eliminate the extension cover at the upper of module.
- (b) Push the module and connect it in agreement with hook for fixation of four edges and hook for connection at the bottom.
- (c) After connection, get down the hook for fixation at the upper part and lower part and fix it completely.

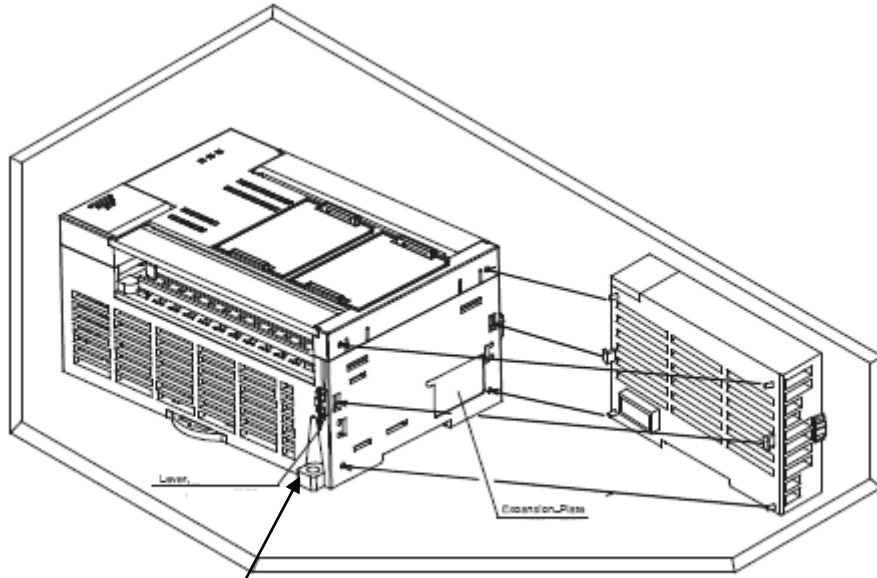

Module fixation (Hook)

(4) Detachment of module

- (a) Get up the hook for fixation of upper part and lower part and disconnect it.
- (b) Detach the module with two hands. (Don't force over-applied force.)

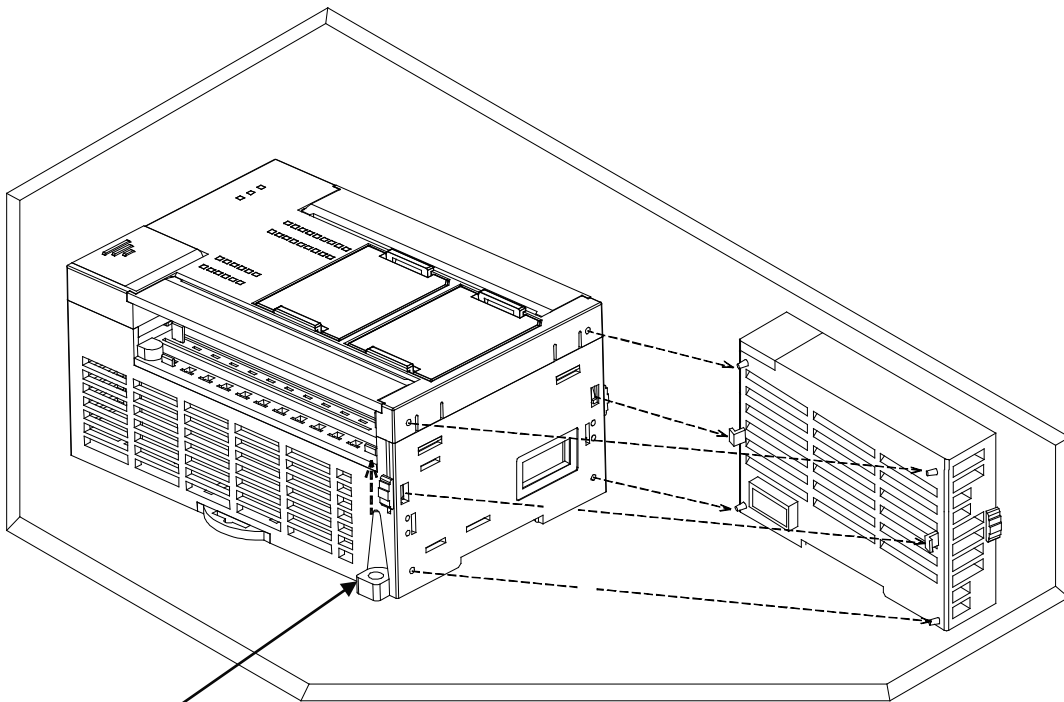

Hook for module fixation

(5) Installation of XGB module

XGB PLC is having hook for DIN rail (rail width: 35mm) so that can be installed at DIN rail.

(a) In case of installing at DIN rail

- Pull hook for DIN rail at the bottom of module and install it at DIN rail
- Push hook to fix the module at DIN rail after installing module at DIN rail

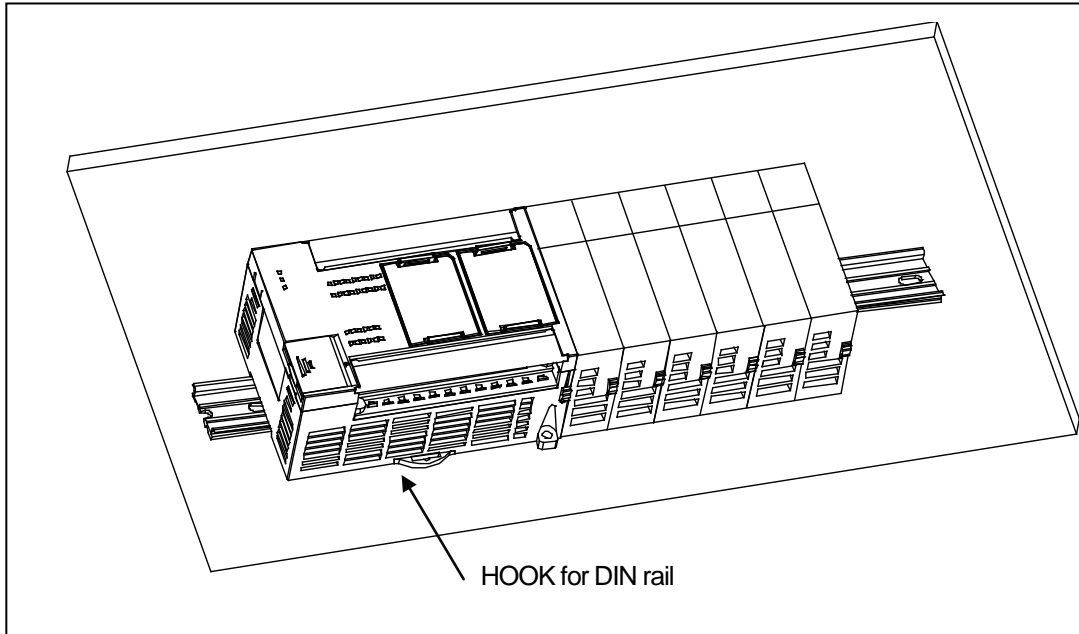

(b) In case of installing at panel

- You can install XGB compact type main unit at panel directly using screw hole
- Use M4 type screw to install the product at panel.

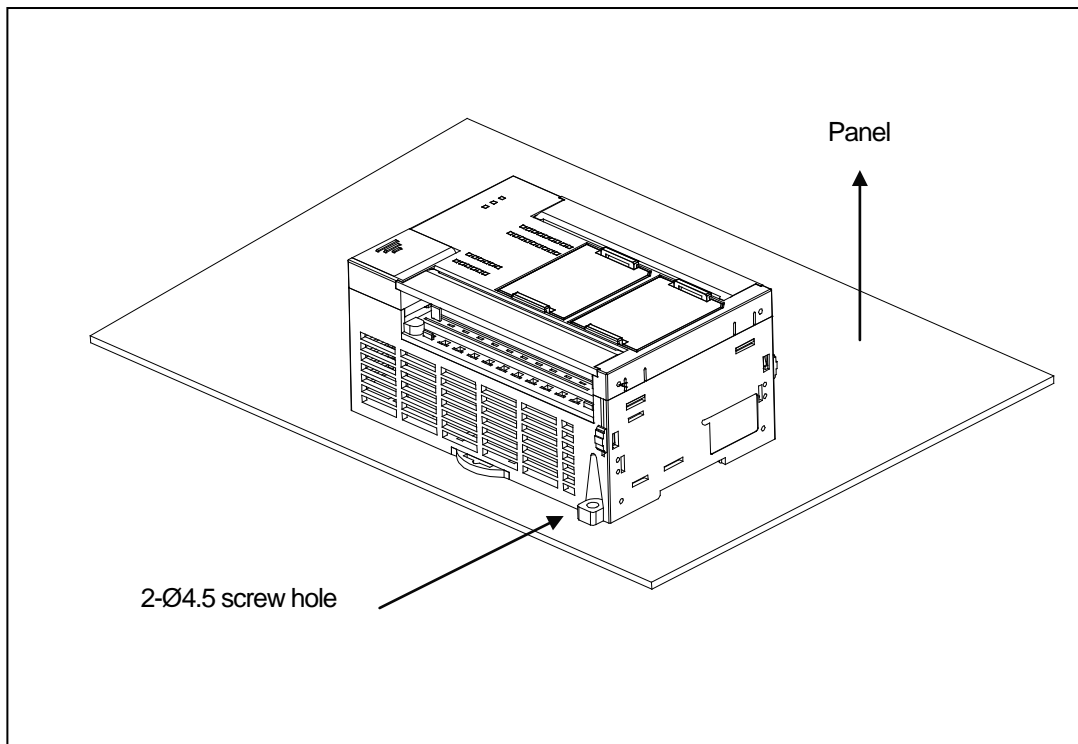

Chapter 3 Installation and Test Operation

(6) XGB module equipment location

Keep the following distance between module and structure or part for well ventilation and easy detachment and attachment.

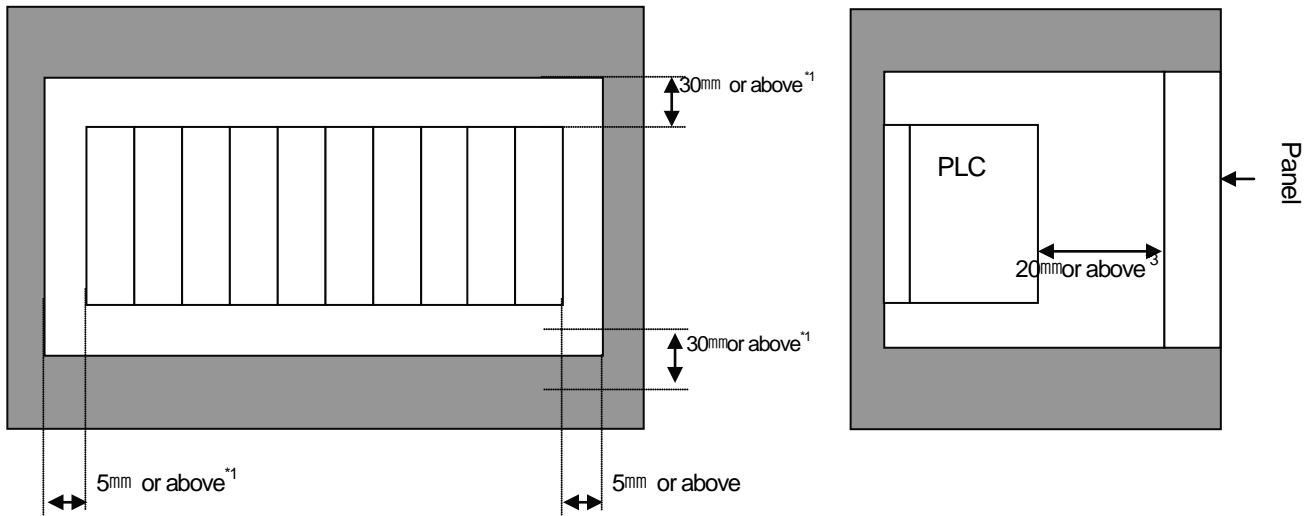

*1 : In case height of wiring duct is less than 50 mm (except this 40mm or above)

*2 : In case of equipping cable without removing near module, 20mm or above

*3 : In case of connector type, 80mm or above

(7) Module equipment direction

(a) For easy ventilation, install like the following figure.

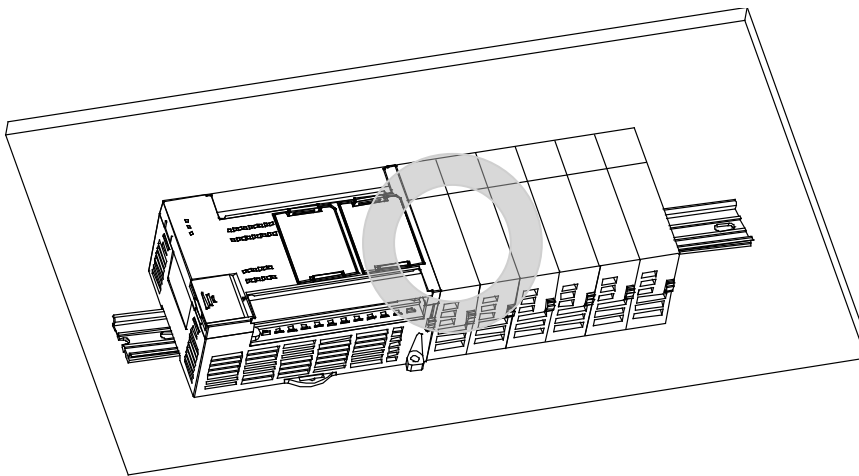

(b) Don't install like the following figure

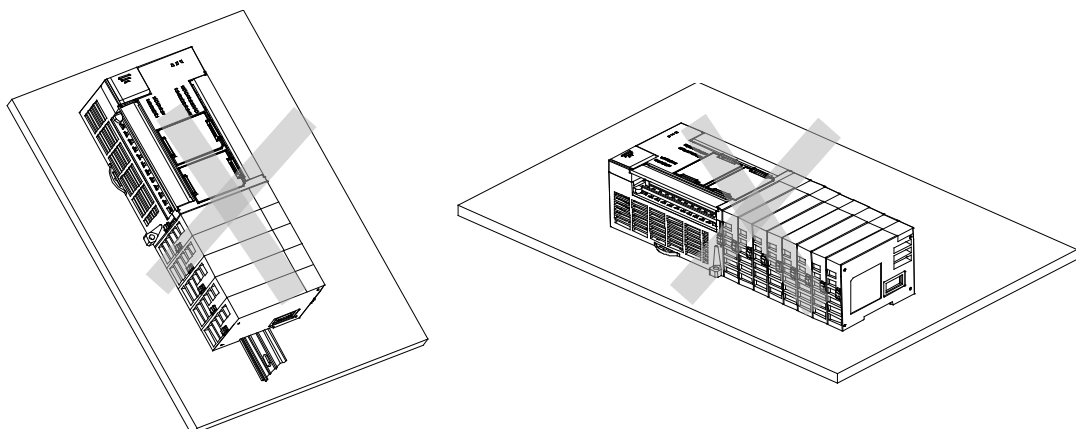

(8) Distance with other device

To avoid radiation noise or heat, keep the distance between PLC and device (connector and relay) as far as the following figure.

Device installed in front of PLC: 100 mm or above

Device installed beside PLC: 50 mm or above

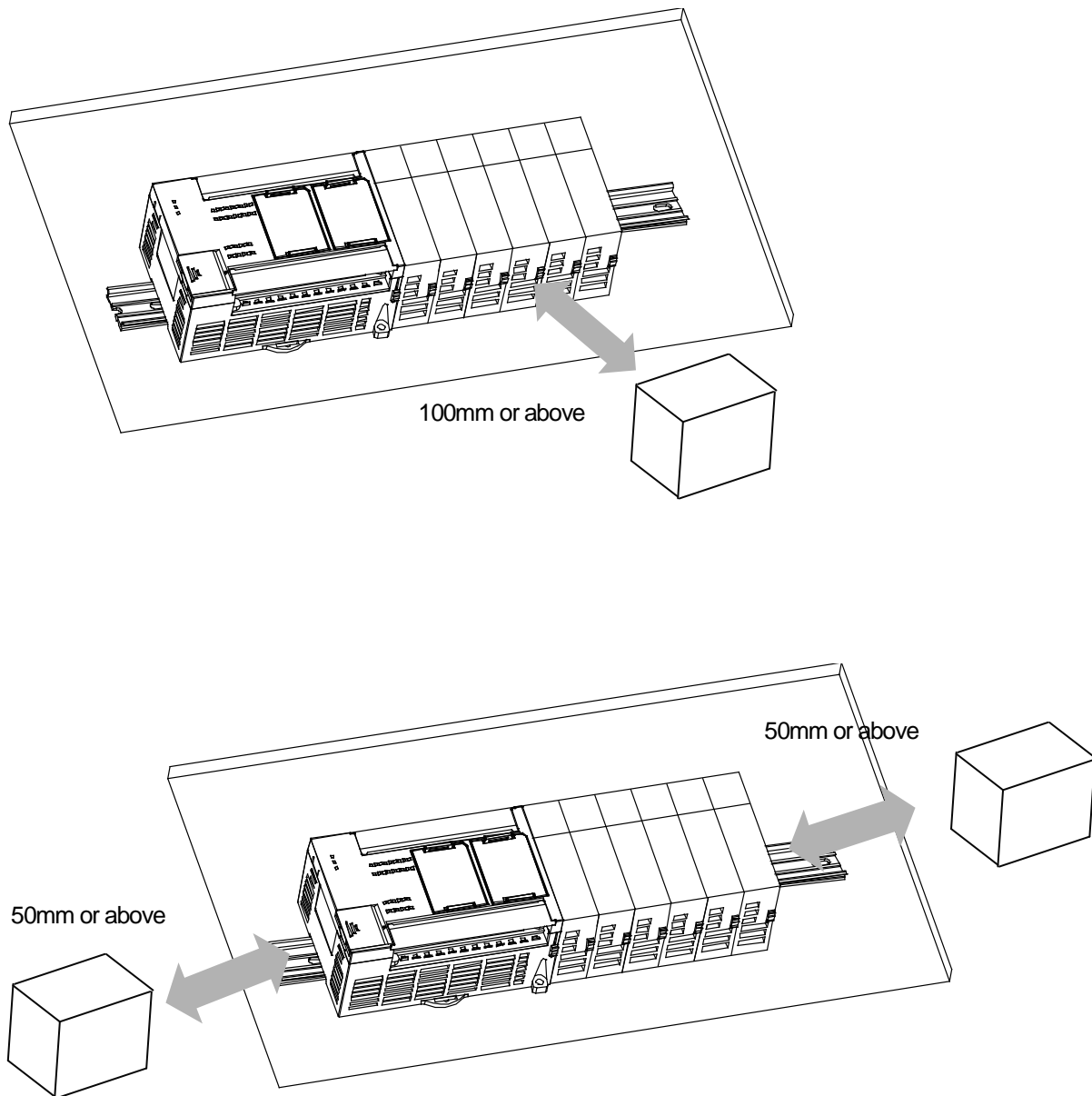

(9) Installation of XOL-ES4T Stand-alone MRS module

XOL-ES4T is having hook for DIN rail (rail width: 35mm) so that it can be installed at DIN rail.

(a) In case of installing at DIN rail

- ① Pull hook for DIN rail at the bottom of module and install at DIN rail.
- ② Push hook to fix the module at DIN rail after installing module at DIN rail.
* Make sure installing stoppers at DIN rail with the module.

(b) In case of installing at panel

- ① You can install XOL-ES4T at panel directly using screw hole.
- ② Use M3 type screw to install the product at panel.

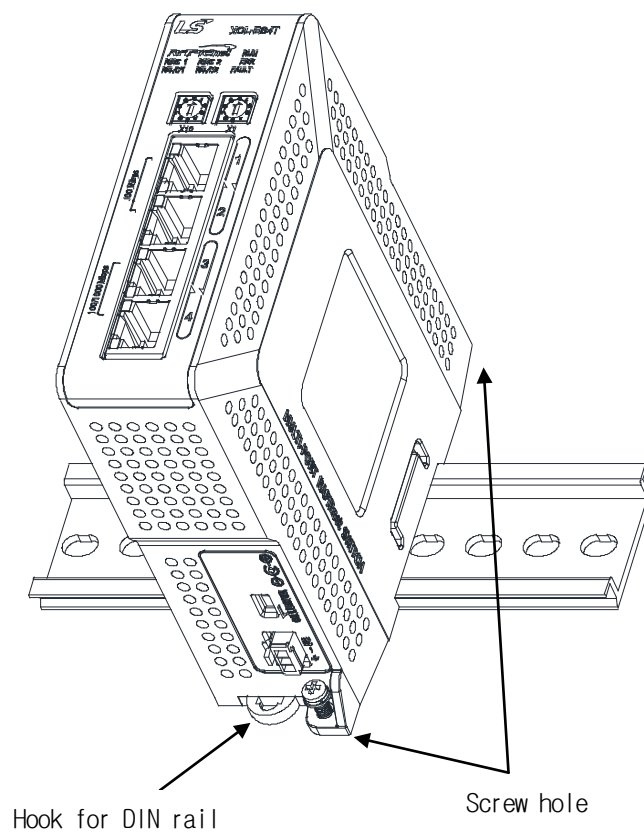

3.2 Precaution for Handling

The system configuration with RAPIEnet I/F module shall be performed under the following precautions.

- (a) Don't let it dropped or shocked hard.
- (b) Don't remove PCB from the case. It will cause abnormal operation.
- (c) Don't let any foreign materials including wiring waste inside the top of the module when wiring.
- (d) Get rid of foreign materials if any.
- (e) Don't install or remove the module while powered on.
- (f) Use standard cable only and let it installed within the maximum distance specified.
- (g) Let the communication cable free from the surge and inductive noise generated by or from the alternating current.
- (h) Don't let wiring too close to hot device and material or in direct contact with oil for long, which will cause damage or abnormal operation due to short-circuit.
- (i) For wiring with pipes, the pipes need grounding.

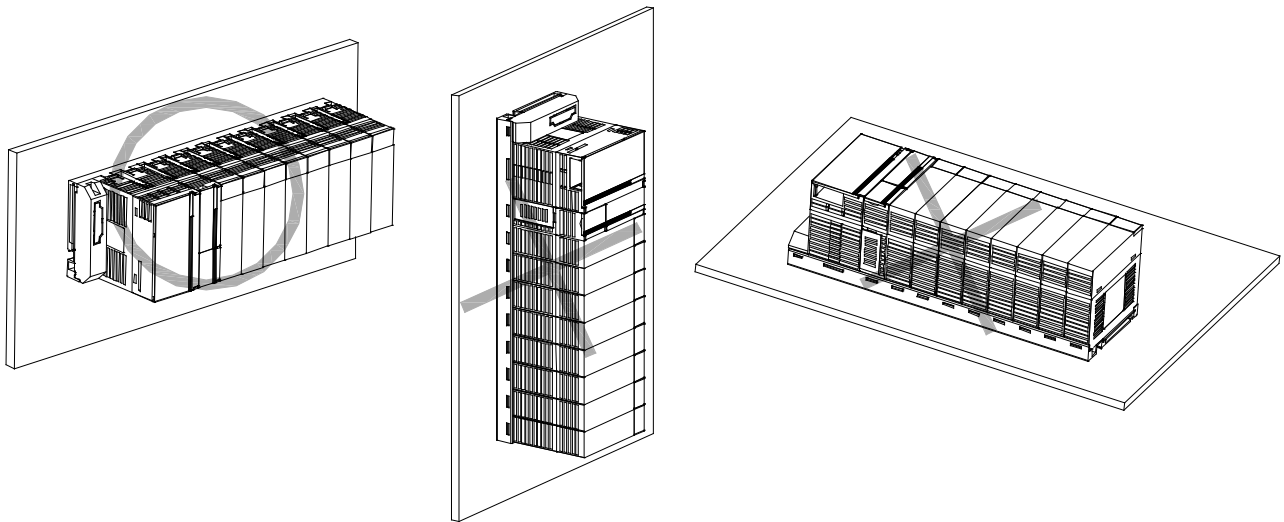

3.3 Sequence from installation to operation

The sequence of the product from installation to operation will be described below. After the product installation is complete, install and configure the system to be operated as specified in the following sequence.

3.3.1 RAPIenet I/F Module for PLC

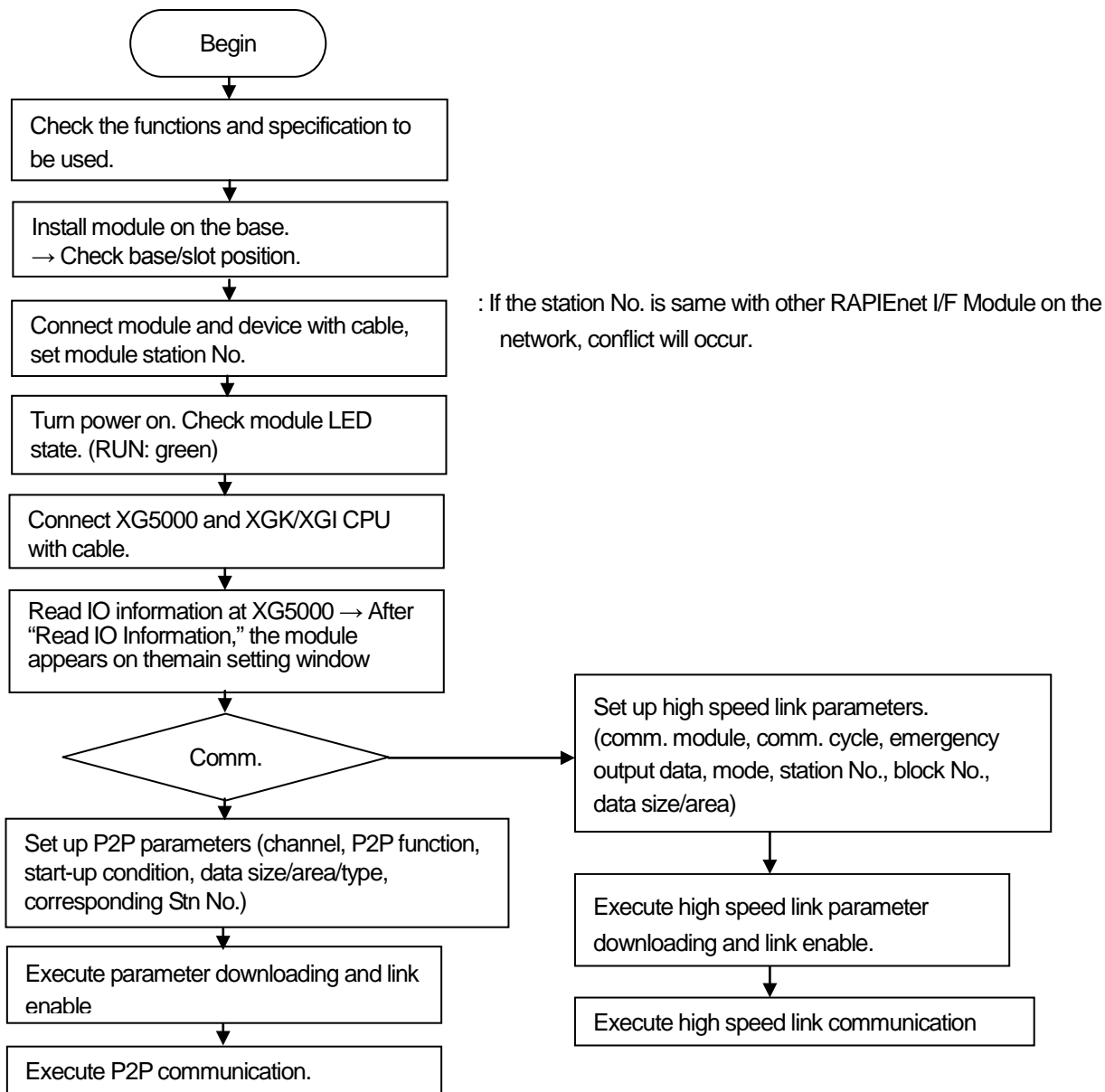

Remark

- 1) Station number of REPIenet I/F module is necessary to set due to hardware properties.

3.3.2 RAPIEnet I/F Module for PC

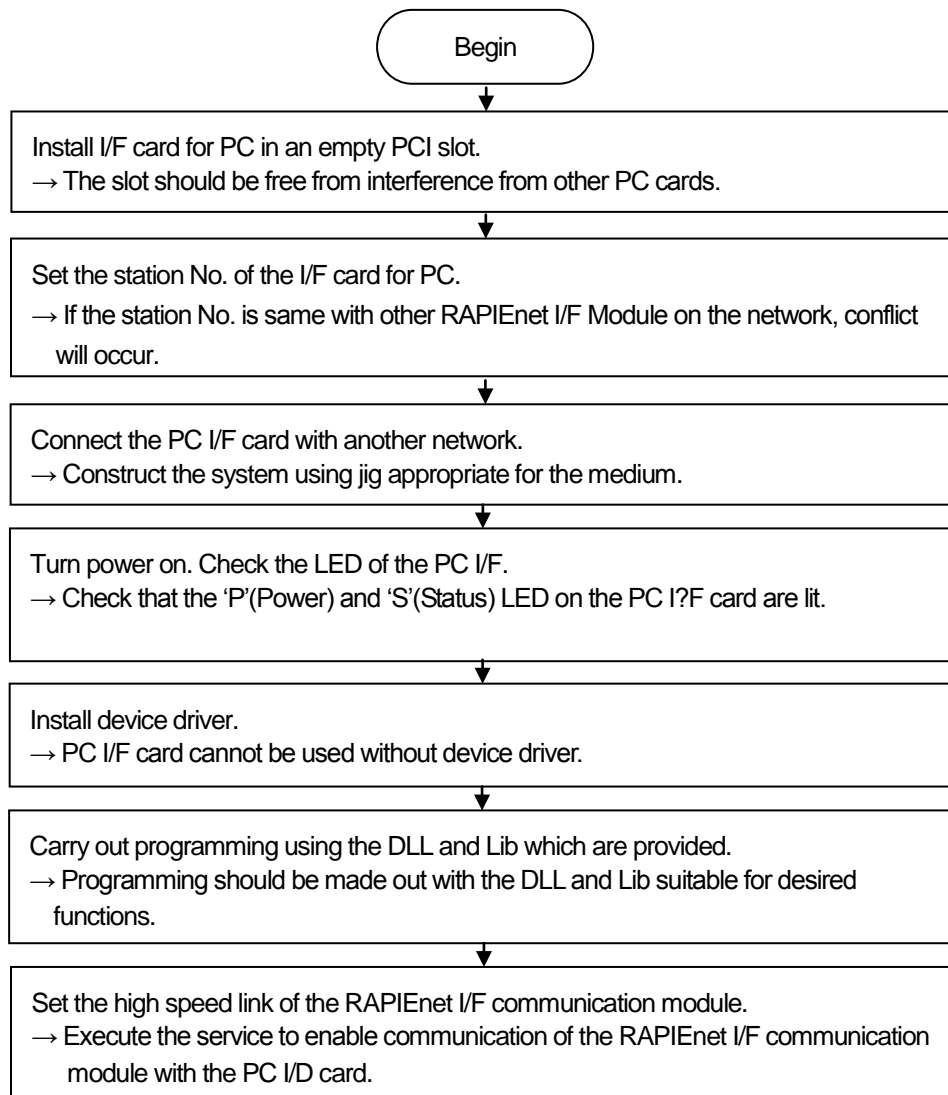
**Note**

1) After setting station number, make sure to turn power on or reset the PC I/F card. The value read from the PC I/F card at the first time setting of station No. is maintained. Change of station No. during communication is not applied in the current operation.

3.3.3 MRS(XGL-ES4T) I/F module

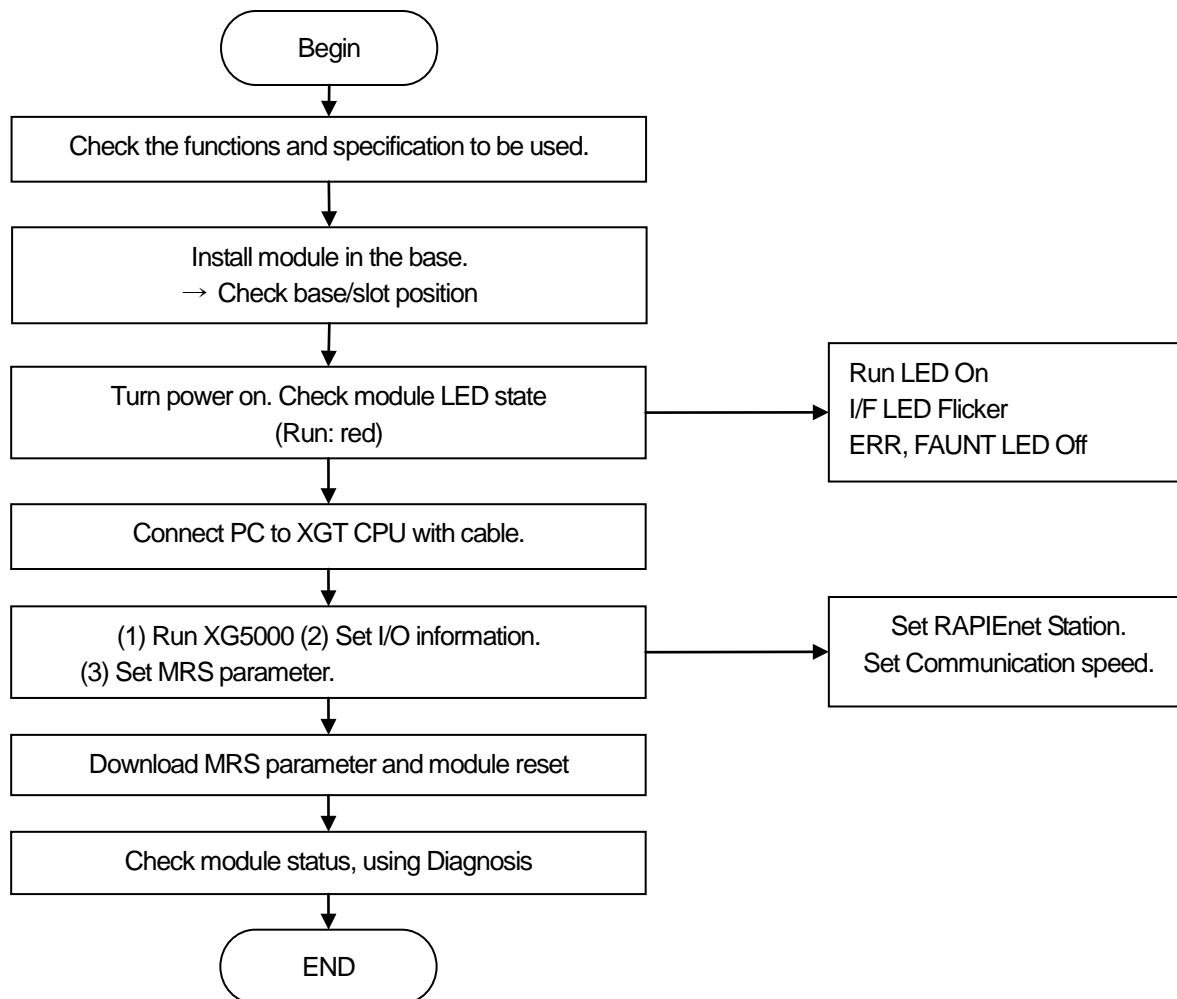

Note

1) XGK/I/R MRS I/F module set parameter(ex: station) through XG5000.

3.3.4 Stand-alone MRS(XOL-ES4T) module

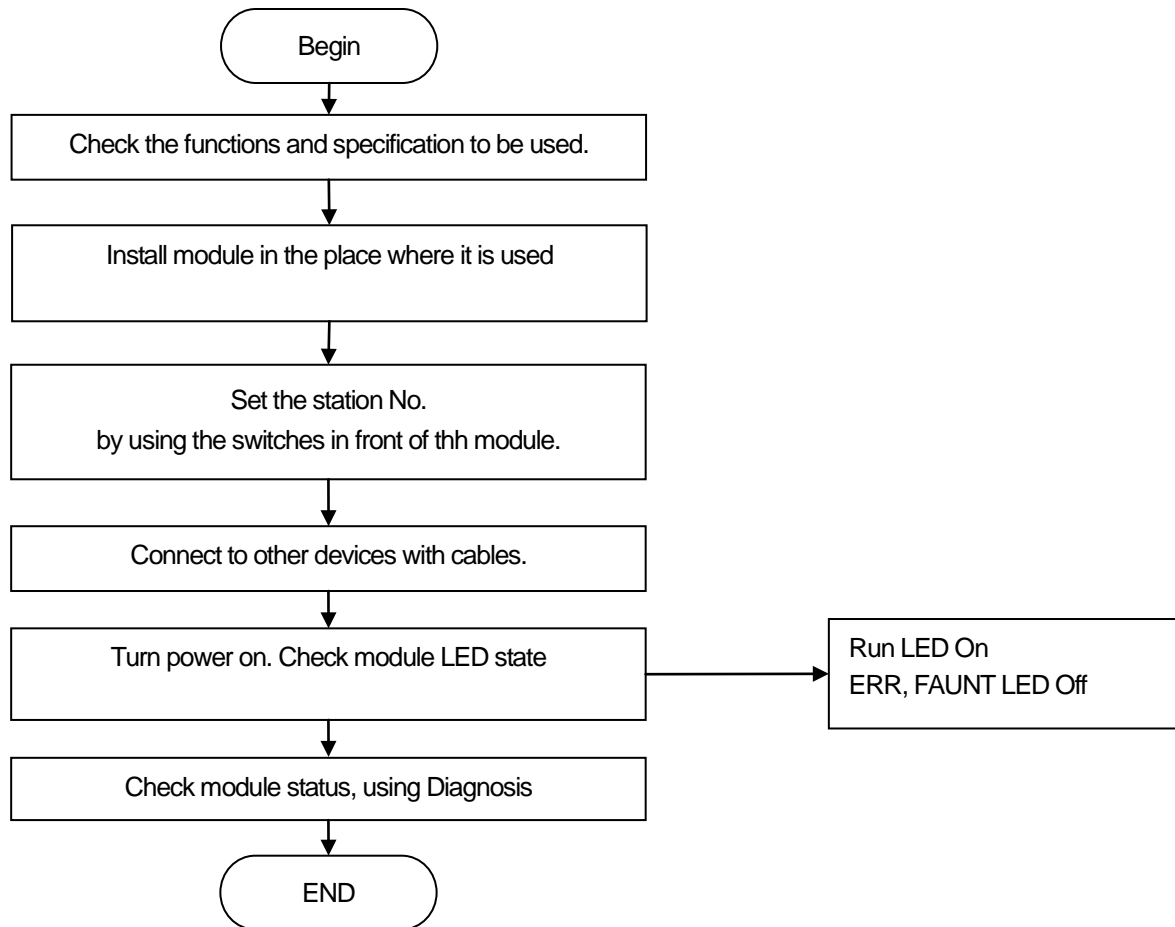
**Note**

1) XOL-ES4T MRS module doesn't need to be set through XG5000.

3.4 Parameter setting in the XG5000

Contents of parameter setting in XG5000 are as follows.

3.4.1 Parameter setting

(1) P2P parameter

Parameter	Lower menu	Setting item	Details	Setting			
				PLC	PC		
P2P	Comm. Module setting	Base	Module position	<input type="radio"/>	-		
		Slot	0 ~ 11	<input type="radio"/>	-		
	P2P block	P2P function	READ		<input type="radio"/>	-	
			WRITE		<input type="radio"/>	-	
		Conditional flag	XGT device	<input type="radio"/>	-		
		Command type	Single		<input type="radio"/>	-	
			Continuous		<input type="radio"/>	-	
		Data type	Bit		<input type="radio"/>	-	
			Byte		<input type="radio"/>	-	
			Word		<input type="radio"/>	-	
			Double Word		<input type="radio"/>	-	
				Long Word		<input type="radio"/>	-
		No. of variables	1 ~ 4	<input type="radio"/>	-		
		Destination station	On/Off	<input type="radio"/>	-		
Destination station No.	0 ~ 63	<input type="radio"/>	-				
Setting	Read area/ Save area /Data size	<input type="radio"/>	-				

(2) High speed link parameter

Parameter	Setting item	Details	Setting	
			PLC	PC
HS link	Mode	Send/Receive	<input type="radio"/>	<input type="radio"/>
	Station No.	0 ~ 63	<input type="radio"/>	<input type="radio"/>
	Block No.	0 ~ 63	<input type="radio"/>	<input type="radio"/>
	Read area	XGT device	<input type="radio"/>	<input type="radio"/>
	Read area word size	1 ~ 200	<input type="radio"/>	<input type="radio"/>
	Save area	XGT device	<input type="radio"/>	<input type="radio"/>
	Save area word size	1 ~ 200	<input type="radio"/>	<input type="radio"/>

3.5 I/O Allocation and Device Information

3.5.1 I/O allocation

(1) Using XGK CPU

(a) Configuration method of basic system

The features of Basic system consisted by connecting the main base and expanded base by a cable are as follows. The number of stages of expanded base is limited according to the CPU type and the allocation method of I/O No. is available to select the **fixed type** and **variable type** according to the setting of basic parameter.

Classification	XGK-CPUE	XGK-CPUS	XGK-CPUA	XGK-CPUH	XGK-CPUU
Max. expanded stages	1stage	3 stages	3 stages	7 stages	7 stages
Max. no. of I/O Module install	24 Modules	48 Modules	48 Modules	96 Modules	96 Modules
Max. I/O point	1,536 points	3,072 points	3,072 points	6,144 points	6,144 points
Max. extended distance	15m				

(b) Allocation of I/O number (Fixed type)

- 1) Each slot of base is allocated by 64 points regardless module installation and type.
- 2) For one base, I/O no. of 16 slots is allocated. That is, the start no. of No.1 base becomes P0640.
- 3) The example of I/O no. of 12 slot base is as below.

Slot No.		0	1	2	3	4	5	6	7	8	9	10	11
P	C	I	I	I	I	O	O	O	O	I	O	O	O
W	P	1	1	3	6	1	3	3	6	3	1	3	3
R	U	6	6	2	4	6	2	2	4	2	6	2	2

P3F P7F P11FP15FP19FP23FP27FP31FP35FP39FP43FP47F

(c) Allocation of I/O no. (Variable type)

- 1) If assigned installation module by I/O parameter, the assigned point is allocated.
- 2) The slot not assigned by I/O parameter shall be allocated automatically according to actual installation slot.
- 3) The slot not assigned by I/O parameter shall be allocated automatically according to actual installation slot (8 point module shall be allocated by 16 point.)
- 4) The empty slot not assigned by I/O parameter shall be processed by 16 point.
- 5) Available to assign the point only by I/O parameter without module assignment.
- 6) The slot installed by special module or communication module is allocated by 16 point.
- 7) The example of I/O no. of 12 Slot base is as below.

Slot No.		0	1	2	3	4	5	6	7	8	9	10	11
P	C	I	I	I	I	O	O	O	O	I	O	O	O
W	P	1	1	3	6	1	3	3	6	3	1	3	3
R	U	6	6	2	4	6	2	2	4	2	6	2	2

P0F P1F P3F P7F P8F P10FP12FP16FP18FP19FP21FP23F

Chapter 3 Installation and Test Operation

- (d) Maximum configuration
 - 1) Max. configuration of basic system (point fixed)

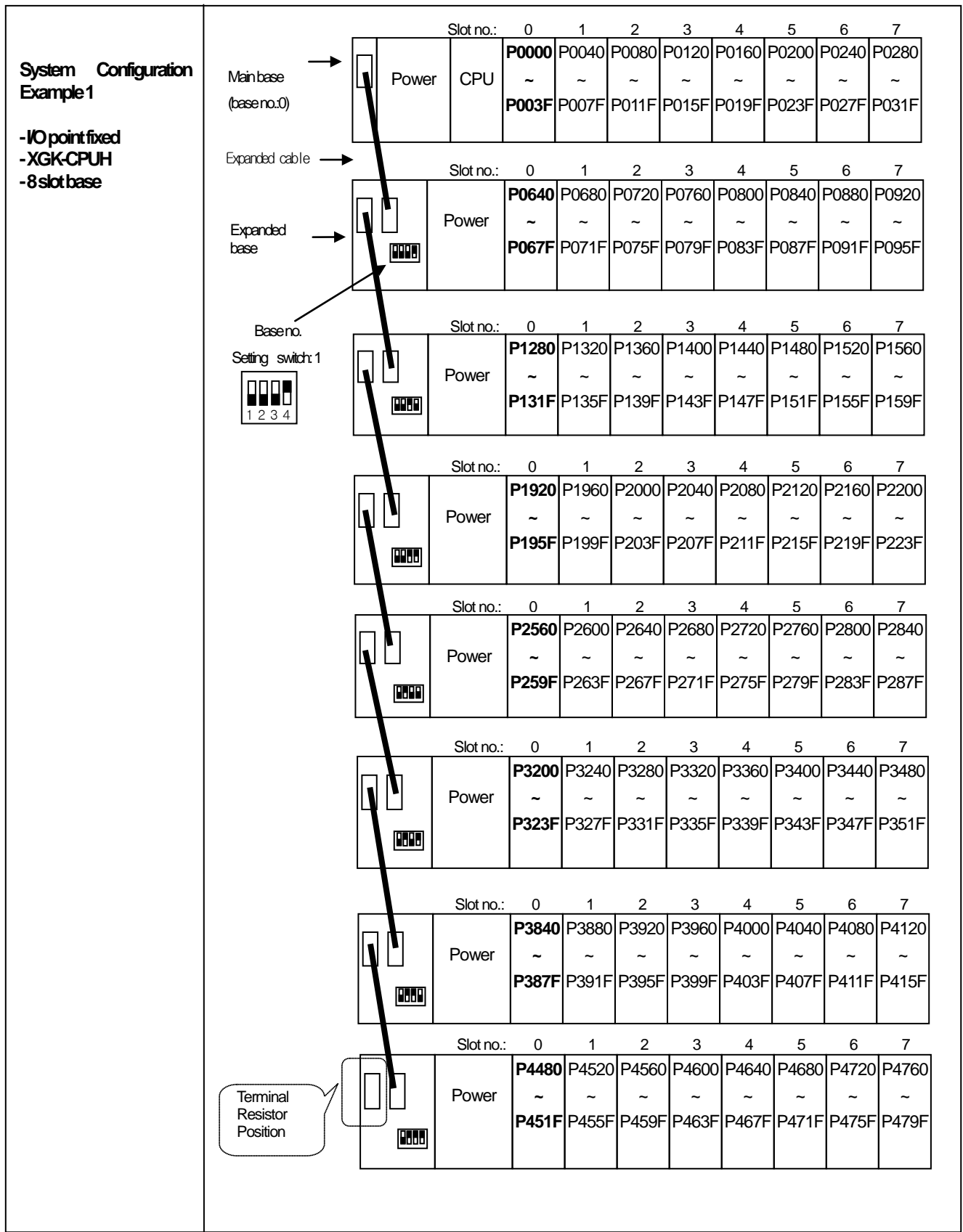

2) Max. configuration of basic system (point variable)

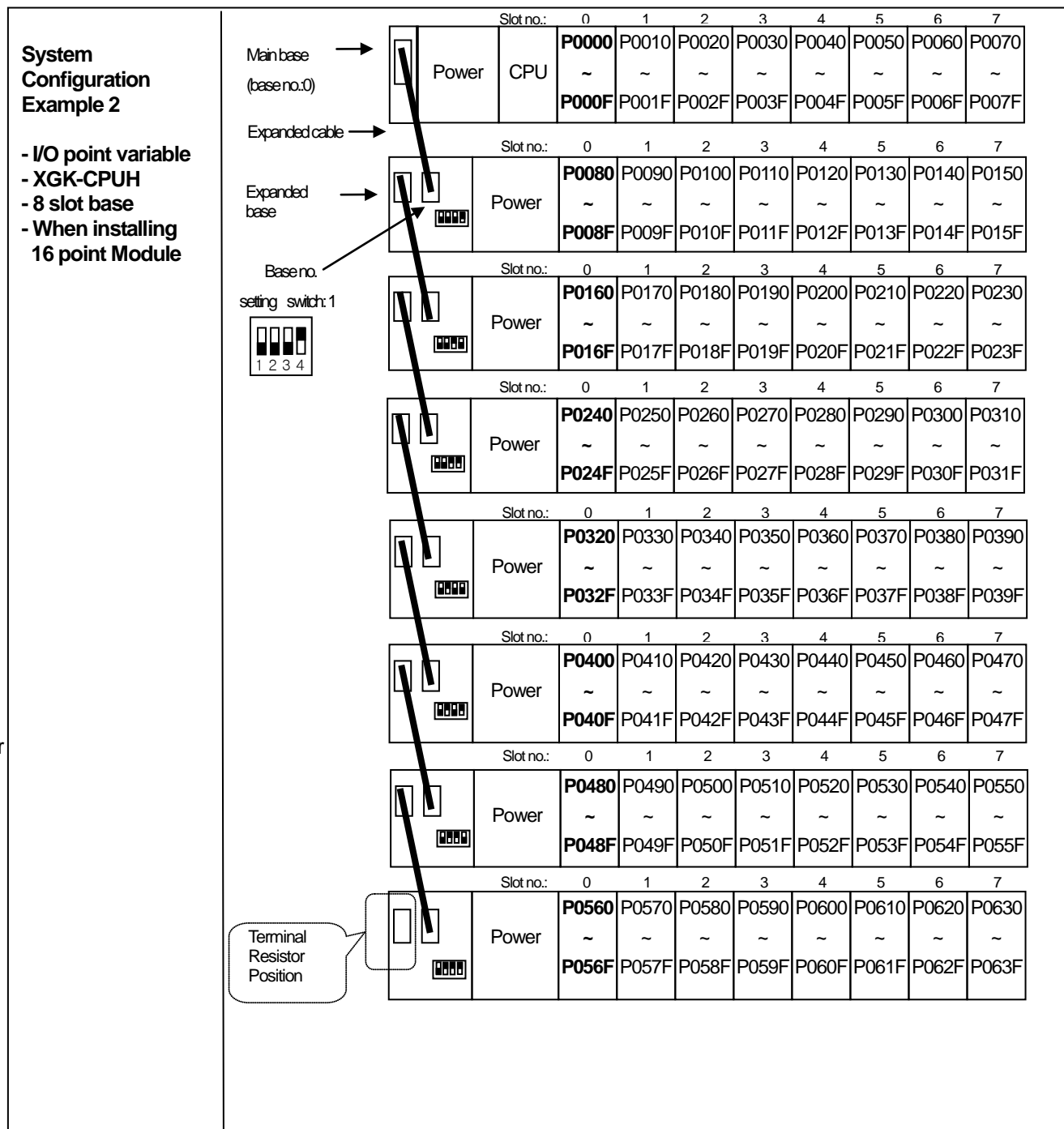

Chapter 3 Installation and Test Operation

(2) Using XGI CPU

(a) Basic system configuration

Classification	XGI-CPUE	XGI-CPUS	XGI-CPUH	XGI-CPUU	XGI-XPUU/D																										
Max. extension stage	1 stage	3 stages	7 stages	7 stages	7 stages																										
Max. number of I/O module extension mounted	24 modules	48 modules	96 modules	96 modules	96 modules																										
Max. I/O contact number	1,536 points	3,072 points	6,144 points	6,144 points	6,144 points																										
Max. extension distance	15m																														
	<ul style="list-style-type: none"> • I/O number is constantly allocated to 64 points per slot of the base. • Each slot of the base is allocated with 64 points, irrespectively of module mounted or its type. • The position on which a special module is mounted or the number is not limited. • Unlike digital I/O module, a special module is not allocated for any constant I/O number. • A special module is controlled by the exclusive function block and automatically allocated for the memory. • For instance, the I/O number of 12 slot base is allocated as follows. <table style="margin-left: 40px;"> <tr> <td>Slot no.</td> <td>0</td> <td>1</td> <td>2</td> <td>3</td> <td>4</td> <td>5</td> <td>6</td> <td>7</td> <td>8</td> <td>9</td> <td>10</td> </tr> <tr> <td>Power</td> <td>C P U</td> <td>I 1 6</td> <td>I 1 6</td> <td>I 3 2</td> <td>I 6 4</td> <td>O 1 6</td> <td>O 3 2</td> <td>O 3 2</td> <td>O 6 4</td> <td>I 3 2</td> <td>O 1 6</td> <td>O 3 2</td> <td>O 3 2</td> </tr> </table> <div style="margin-left: 40px; margin-top: 10px;"> <p style="margin-left: 20px;">Base no. 1</p> </div>					Slot no.	0	1	2	3	4	5	6	7	8	9	10	Power	C P U	I 1 6	I 1 6	I 3 2	I 6 4	O 1 6	O 3 2	O 3 2	O 6 4	I 3 2	O 1 6	O 3 2	O 3 2
Slot no.	0	1	2	3	4	5	6	7	8	9	10																				
Power	C P U	I 1 6	I 1 6	I 3 2	I 6 4	O 1 6	O 3 2	O 3 2	O 6 4	I 3 2	O 1 6	O 3 2	O 3 2																		

Remark

- 1) The basis base has its base number as '0' and the extension base has a switch to set the base number.
- 2) Operation starts as long as the module type set as I/O parameter and the actually mounted module type coincide.

(b) Max. system configuration

System Configuration
Example 2

- XGI-CPUU
- 8 slot base
- When installing 16 point Module

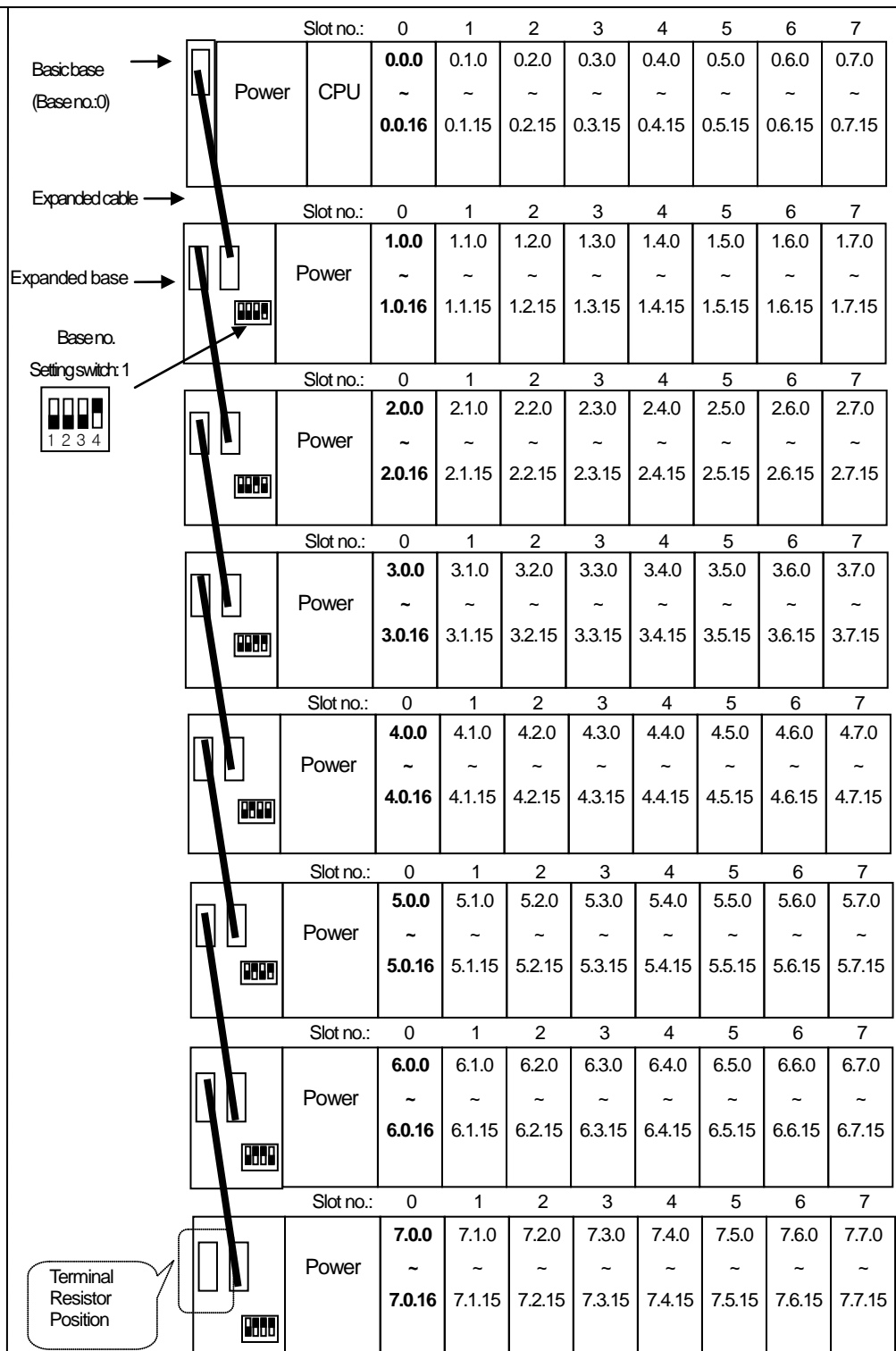

3.6 Installation

3.6.1 Installation of XGL-EIMT and XOL-EIMT

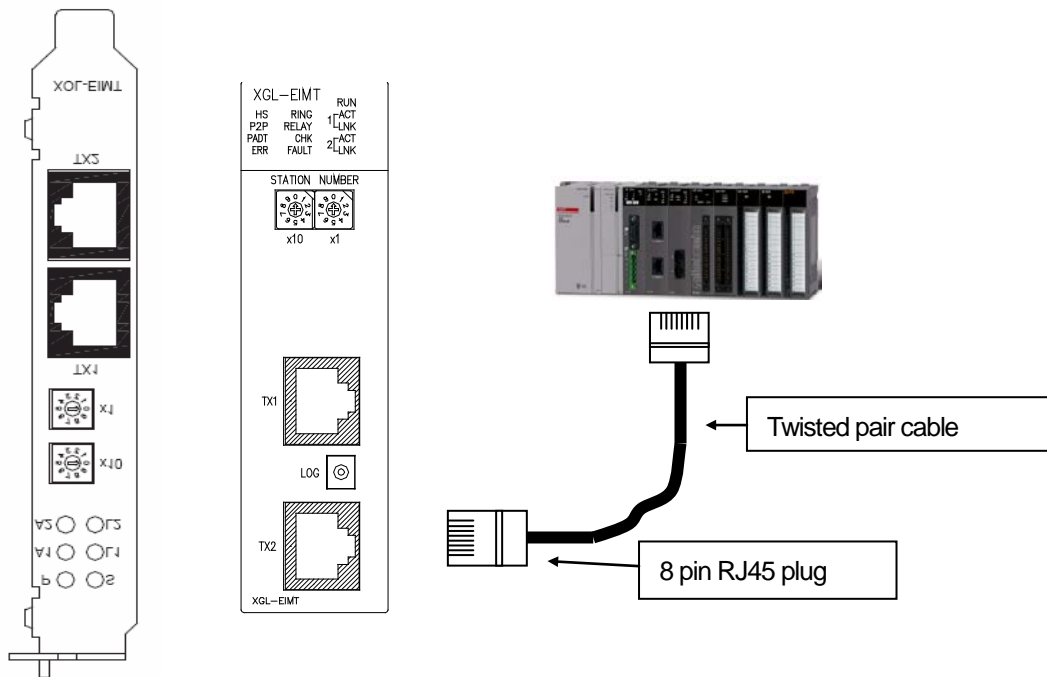

[Fig. 3.6.1] 100BASE-TX Installation

The max. segment length of 100BASE-TX is 1000 m (distance from module to module).
Use Straight cable or Cross cable.

Pin No.	Signal	Straight cable between modules	1:1 cross cable
1	TD+	1-1	1-3
2	TD-	2-2	2-6
3	RD+	3-3	3-1
6	RD-	6-6	6-2
4,5,7,8	Not used	-	-

Remark

1) Since the structure of 10/100BASE-TX cable is vulnerable to external noise, the cable needs to be stranded as twisted (two lines twisted with each other) between cables of the pin No.1 and 2 of TD+ and TD- and between cables of the pin No.3 and 6 of RD+ and RD- so to be strong against noise

2) Contact professional manufacturers for processing cable terminal, manufacture and installation.

(1) UTP installation

- (a) In order to transmit reliable 100Mbps sign with UTP cable, characteristics of patch cord, line cord, patch panel and DVO (Data Voice Outlet) shall conform to the Category 5 Spec. (EIA/TIA-568A).
- (b) Be careful not to allow the length of patch cord to exceed 7m in cross-connect system. If 7m is exceeded, such subtraction as long as exceeded is required within the allowable value of 90m in Horizontal Distribution System.
- (c) The length of line cord shall not exceed 3m in the workstation. If 3m is exceeded, such subtraction as long as exceeded is required within the allowable value of 90m in Horizontal Distribution System.
- (d) When wiring between patch panel and DVO, the pair pitch of UTP cable shall not be loosened over the following measurements.
 - * Max. pair pitch loosened: Category 5: 13 mm
Category 3: 26 mm
- (e) Use the jumper wire in IDC cross-connect system, and the pair pitch shall not be loosened over the above-specified measurements either at this time. Especially, be careful not to bend the cable intensely, which may cause not only damage but also distance between pairs.
 - * Max. radius of curvature: 4-pair cable : 4 times of external diameter
Cable with 25 or more pairs: 10 times of external diameter
- (f) Max. tension strength during wiring shall not exceed 110 N (11.3 Kgf), based on 4-pair cable.
- (g) Jumper wire and patch code shall be wired rather loosely. If wired too tight, the characteristics of Category 5 may be deteriorated. If Tie-wrap is used, be careful not to apply stress on the cable.
- (h) When UTP cable is installed, a suitable distance shall be maintained between EMI source and UTP cable.

The suitable distance for each case is as specified in the table below;

Condition	Min. separation distance		
	2.0 kVA or less	2.5 kVA	5.0 kVA or more
Power line unshielded, or electric facility open or near to nonmetallic pipe	127 mm	305 mm	610 mm
Power line unshielded, or electric facility near to metallic pipe buried	64 mm	152 mm	305 mm
Power line inside metallic pipe buried (or equivalently shielded) near to metallic pipe buried	-	76 mm	152 mm

Remark

- 1) If voltage is 480 V, rated power is 5 kVA or more, separate calculation is needed.

3.6.2 Installation of XGL-EIMF and XOL-EIMF

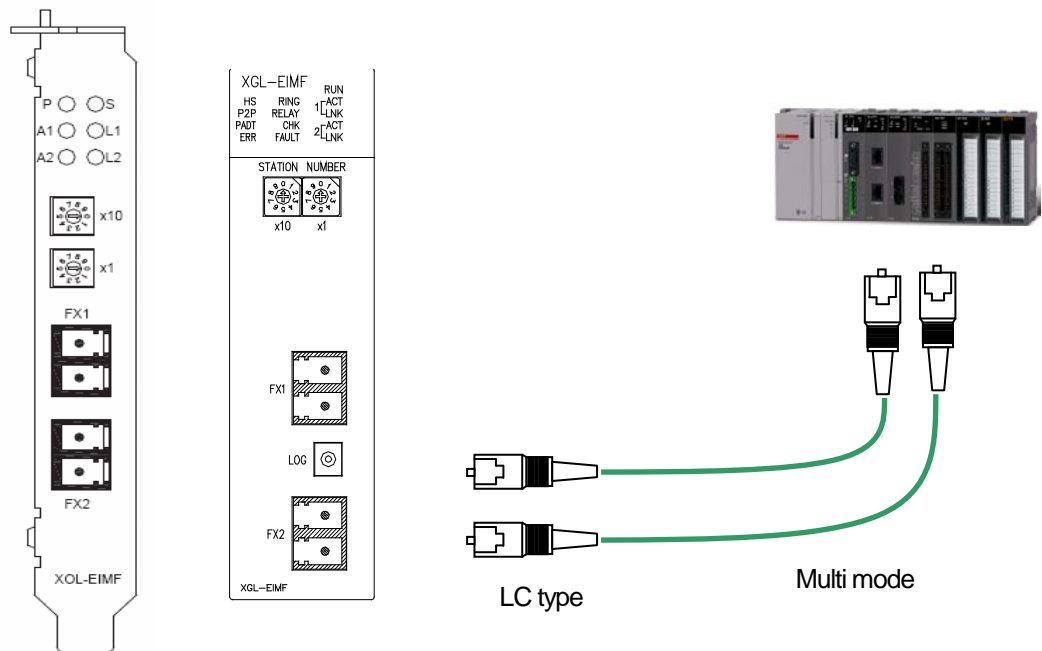

[Fig. 3.6.2] 100BASE-FX Installation

The max. segment length of XGL-EIMF is 2000 m (distance from this module to the module). Let the module's Tx cross-connected with the other module's Rx, and the module's Rx with the other module's Tx.

Remark

- 1) Since the optical cable is vulnerable to impact, pressure, folding and pulling, pay good attention to its treatment. The optical contact between the connector and the end of the cable may have communication errors if contaminated, which may result in unavailable communication. If the cable is installed outdoors, additional countermeasures are required to protect the cable suitably for the installation environment.

3.6.3 Installation of XGL-EIMH

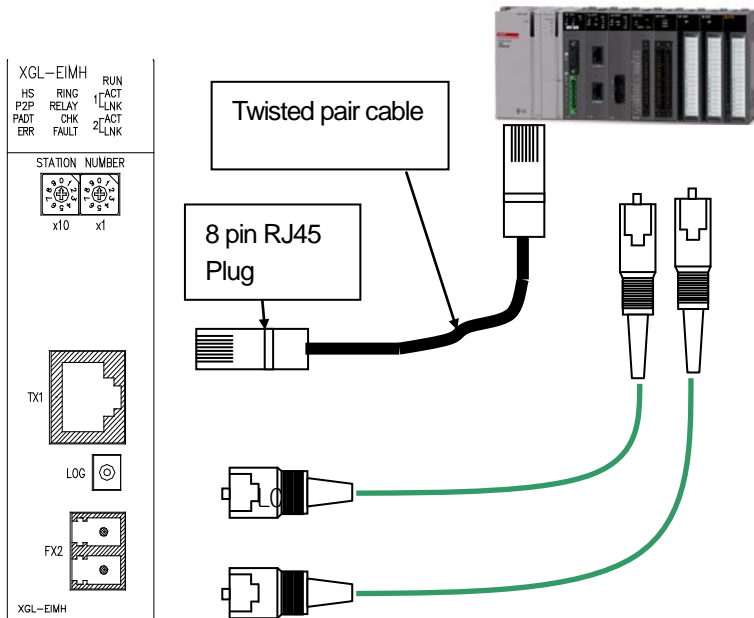

[Fig. 3.6.3] 100BASE-TX/100BASE-FX installation

3.6.4 Installation of XGL-ES4T and XOL-ES4T

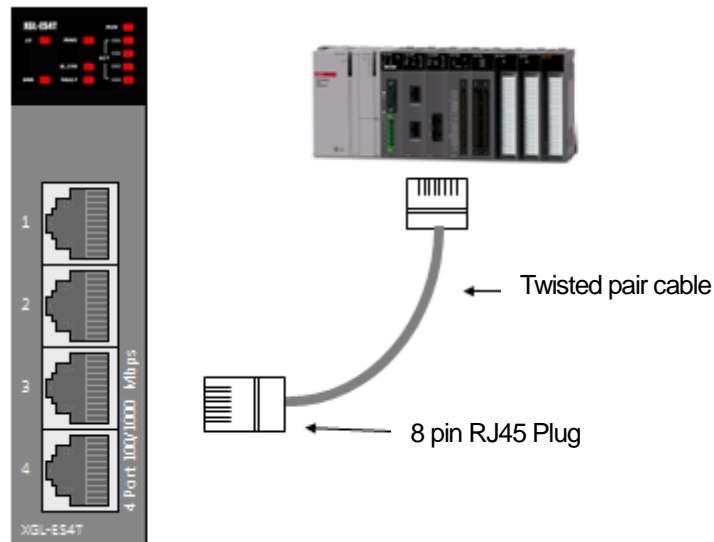

[Fig. 3.6.4] 100BASE-TX installation

The max. segment length is 100 m (100Mbps, 1Gbps, Above category 5).

Use Straight cable or Cross cable.

If you use cross cable for connecting two modules, you can save the connection time.

Refer to Ch 3.6.1, you can install UTP cable.

Pin No.	Signal	Straight cable between modules	1:1 cross cable
1	TD+	1-1	1-3
2	TD-	2-2	2-6
3	RD+	3-3	3-1
6	RD-	6-6	6-2
4,5,7,8	Not used	4-4, 5-5, 7-7, 8-8	4-4, 5-5, 7-7, 8-8

3.7 Test Operation

3.7.1 Precautions for system configuration

- a) HS link station No. of all stations shall be different from each other including this module in order to use HS link service.
- b) Use the communication cable as specified only. If not, serious error may occur to communication.
- c) Check communication cable if disconnected or shorted prior to installation.
- d) Tighten up communication cable connector until connected firmly. If cable connection is unstable, serious error may occur to communication.
- e) If remote communication cable is connected, keep the cable far away from power line or inductive noise.
- f) Since the coaxial cable is not flexible, it is to be diverged min. 30cm away from the connector in communication module. If the cable is bent at a right angle or transformed compulsorily, cable disconnection or connector damage in communication module will be caused.
- g) If LED operation is abnormal, refer to Chapter 10 Troubleshooting to check for causes and take actions against. Contact Customer Service center if the error is as before.

Chapter 4 System Configuration

RAPIenet I/F module can be installed regardless of XGT CPU module. Maximum number of installation is 24 including basic base and extension base. Among those, 8 modules can be used as P2P service. If you use dedicated protocol, all 24 modules can be used.

Applicable system configuration is described below.

4.1 Available System Configuration

4.1.1 Ring type system with electric module

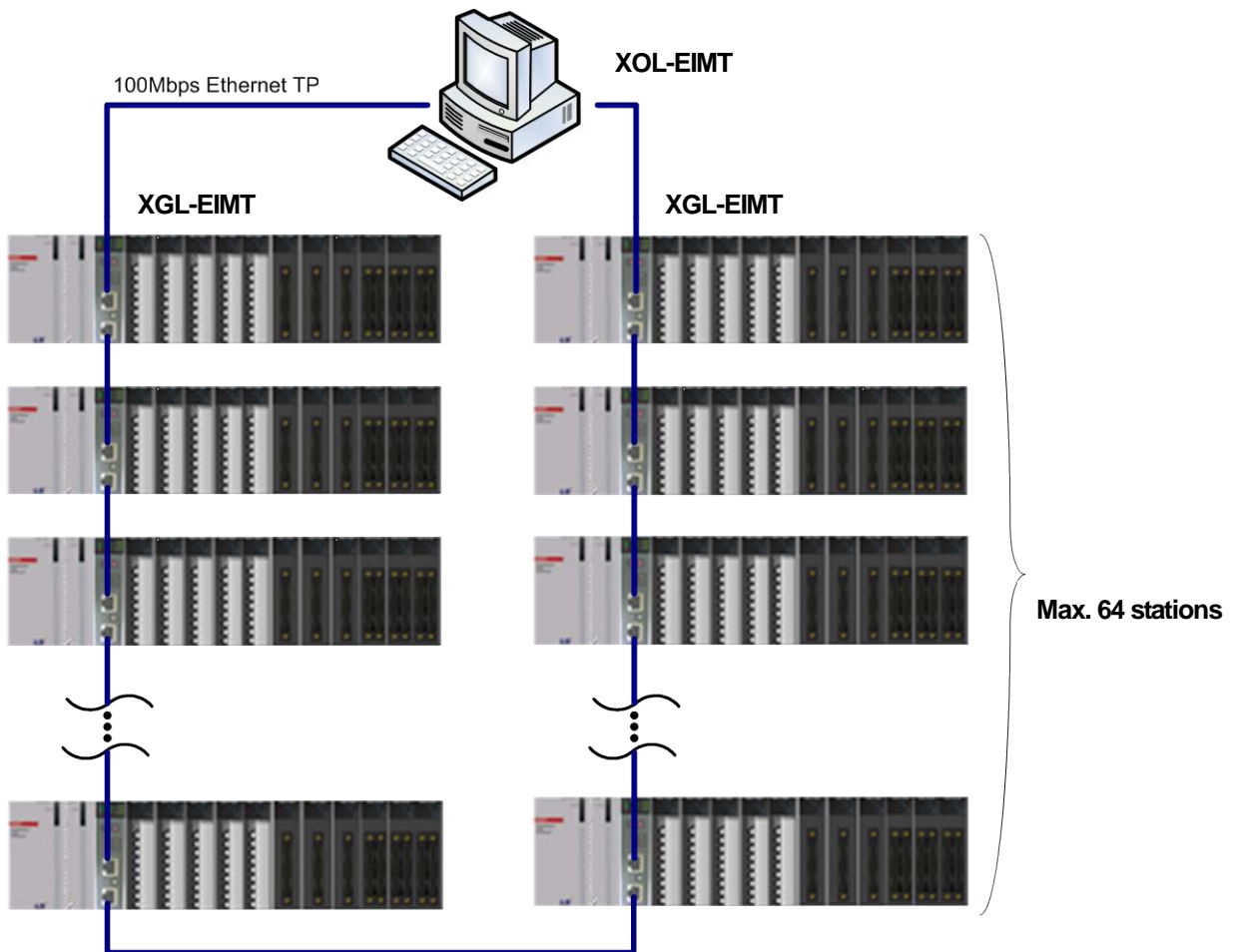

[Fig. 4.1.1] System configured by electric module

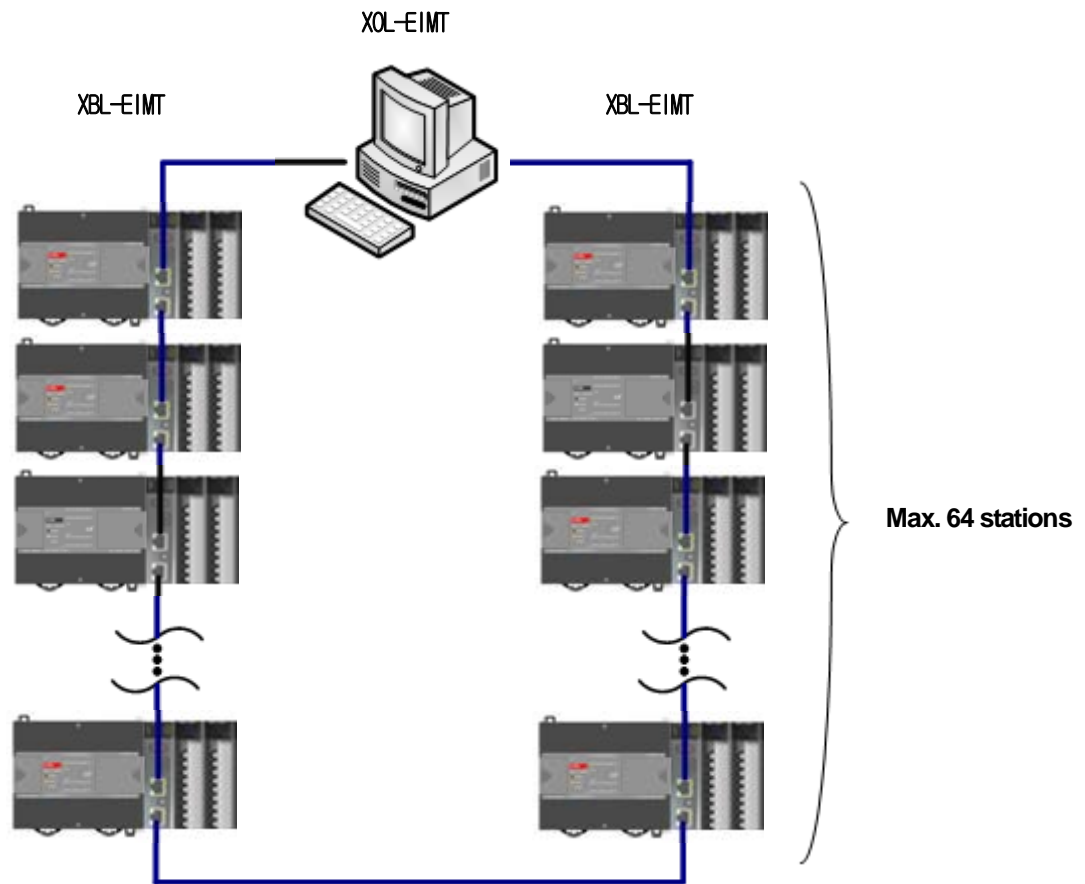

[Fig. 4.1.2] System configured by XBL-EIMT

Note

- 1) In case of XGB. Maximum number of installation is 2 at XGB main module and it's System Configuration are in the same as XGB RAPIenet I/F

4.1.2 Ring type system with optical module

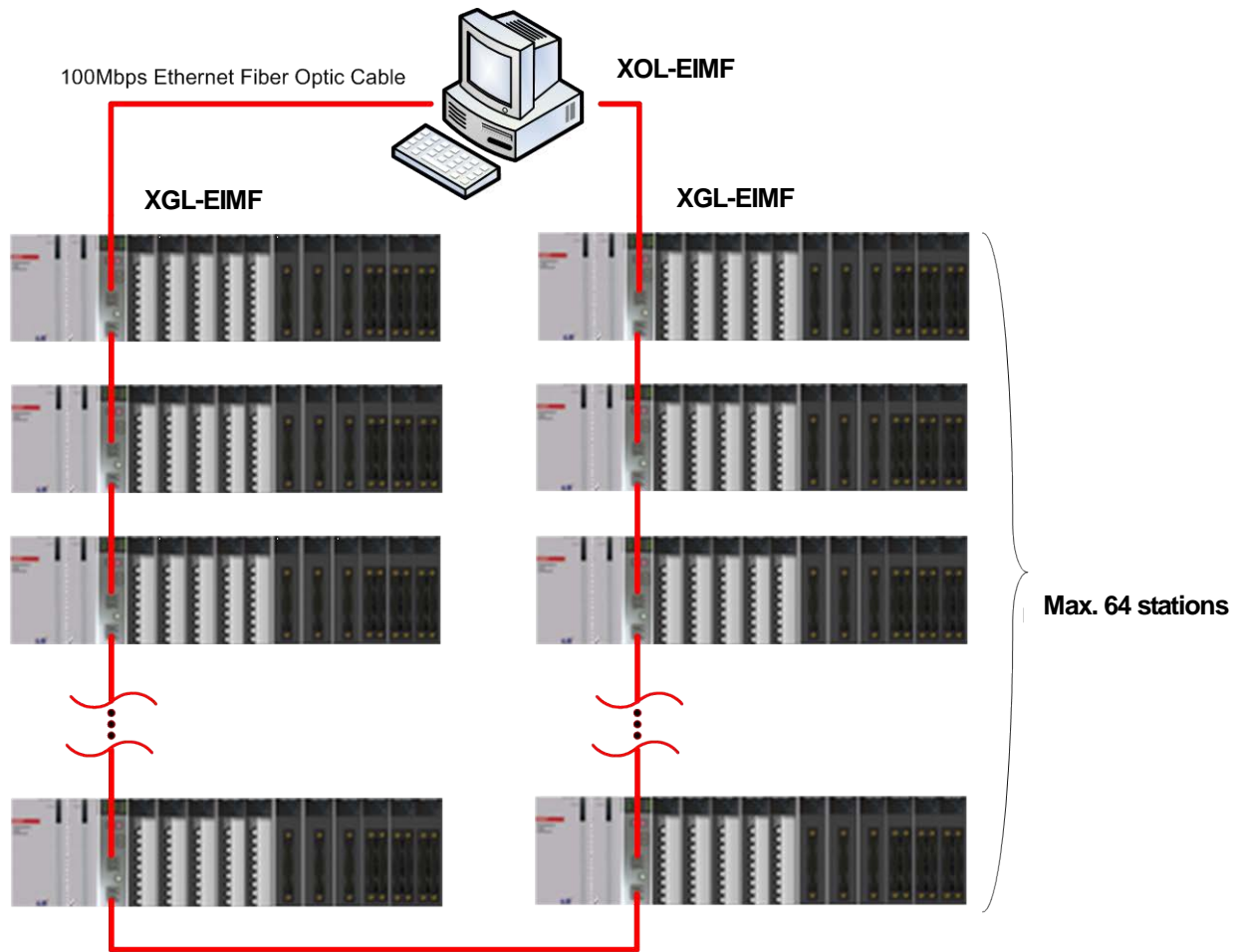

[Fig. 4.1.3] System configured with optical module

4.1.3 Ring type system with combined module

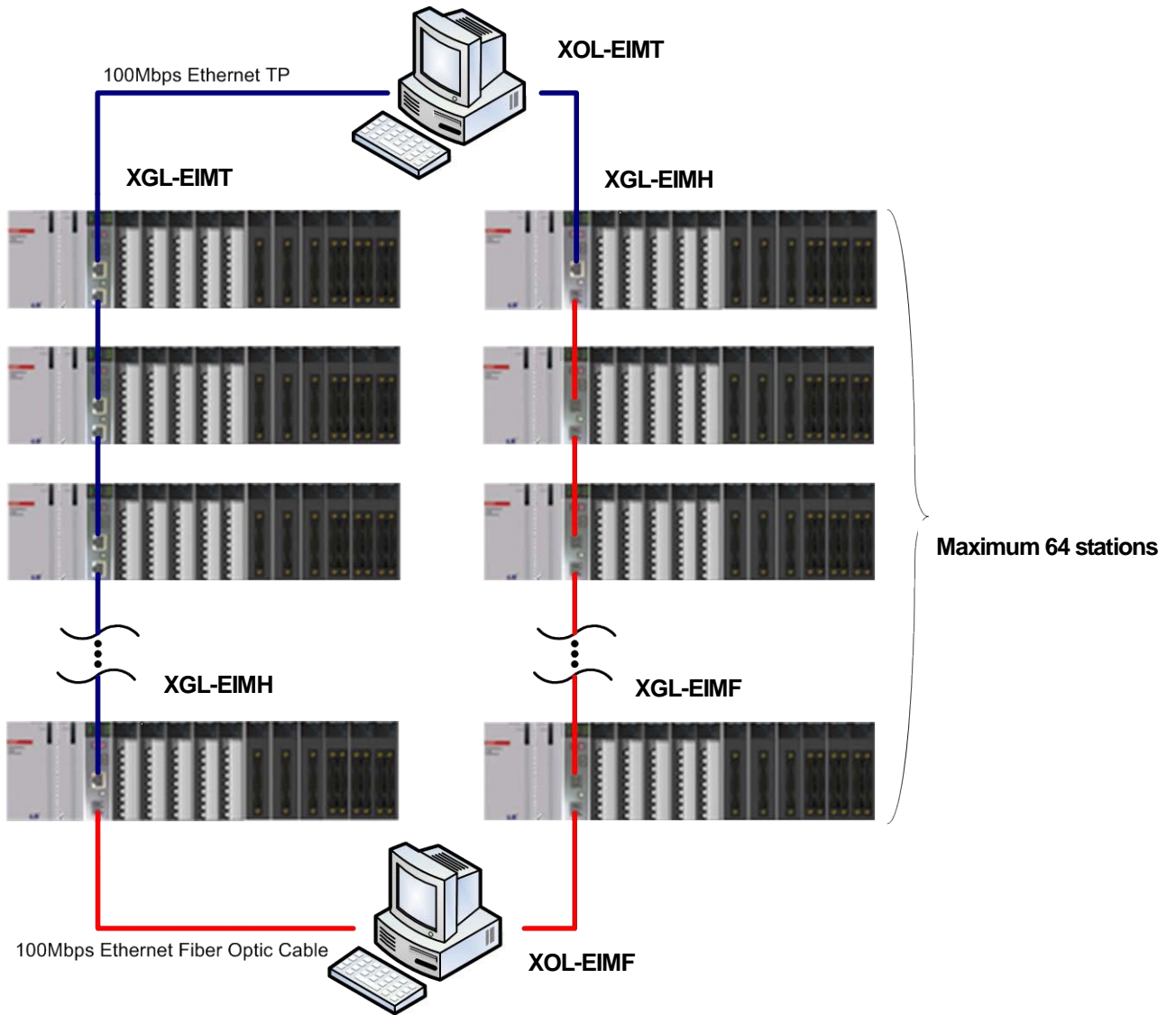

[Fig. 4.1.4] System configured combined module

4.1.4 Line type system with optical module

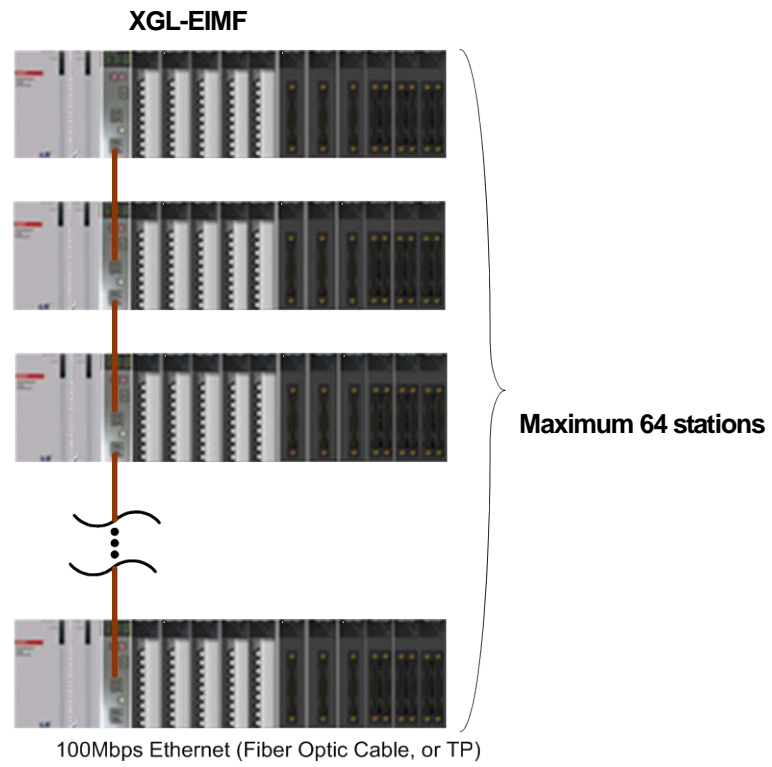

[Fig. 4.1.5] Line type system configured optical module

Electric module and combined module also can be used to configure line type system.

4.1.5 System with XGL-ES4T MRS module

(1) Available system with MRS module

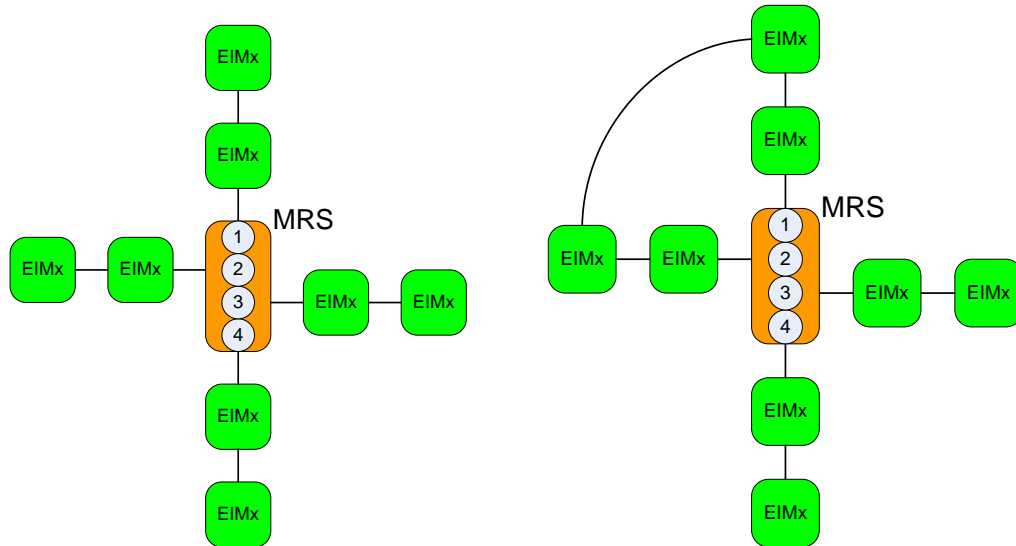

Note

- 1) MRS can mount Basic base and extension base in XGK/XGI system(Can mount 1 module per base)
But, MRS can mount Extension base in XGR system.
- 2) MRS can Ring configuration(1,2 port), MRS can Line configuration(1,2,3,4 port)
- 3) MRS Cannot connect two MRS modules(only use 1 module in system)

(2) Not available system with MRS module

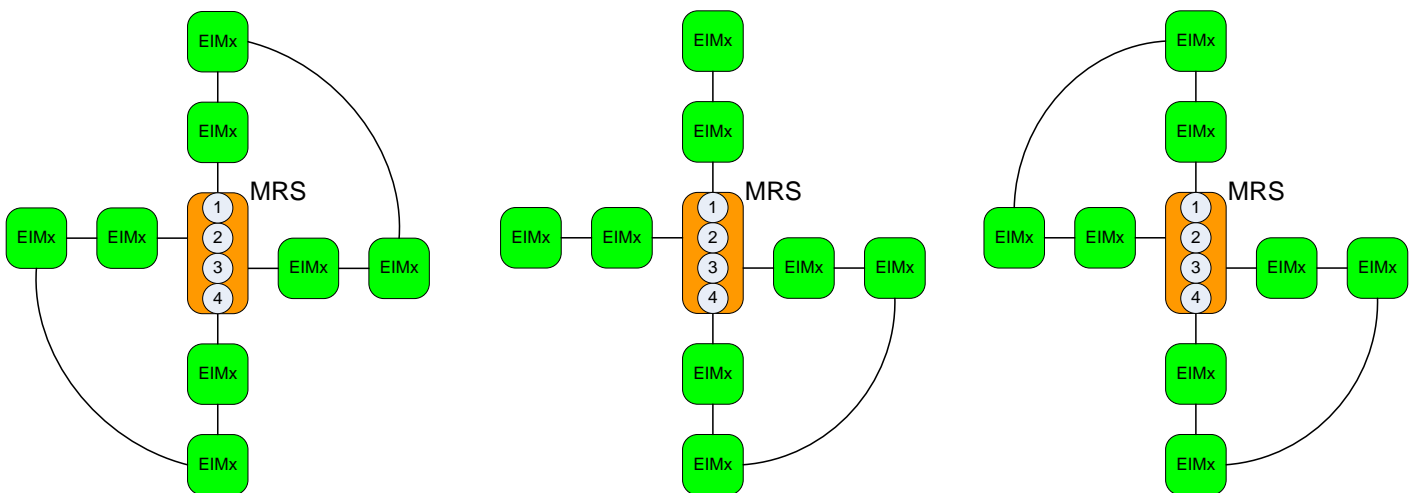

4.1.6 System with XOL-ES4T Stand-alone MRS module

- Stand-alone MRS is able to connect with RAPIEnet and be used Ethernet Hub.

Refer to the below system configuration.

(1) RAPIEnet system configuration

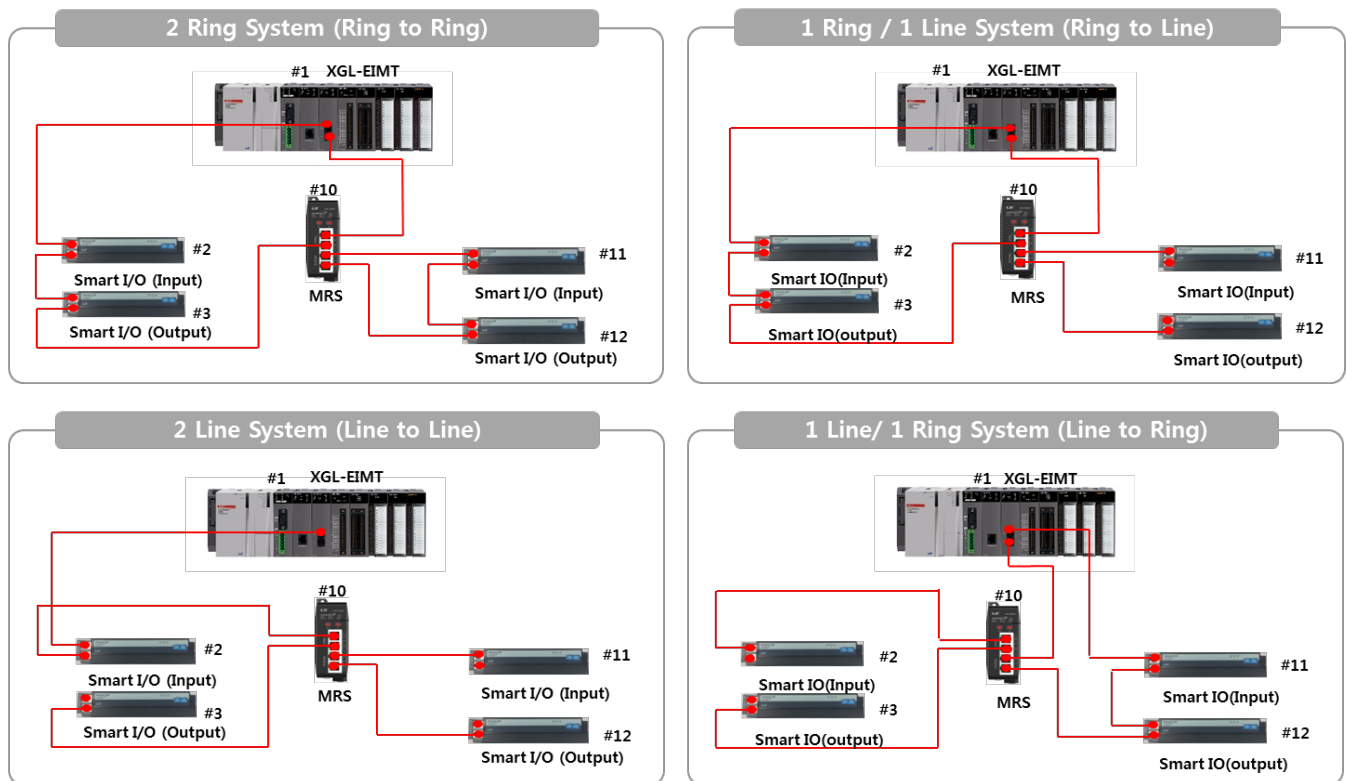

Note

- 1) XOL-ES4T MRS cannot connect two MRS modules(only use 1 module in system)
- 2) XOL-ES4T must be supplied with DC24V power.
- 3) XOL-ES4T is a stand-alone product that is used without connecting to the base.

Chapter 4 System Configuration

(2) RAPIenet / Ethernet or only Ethernet system configuration

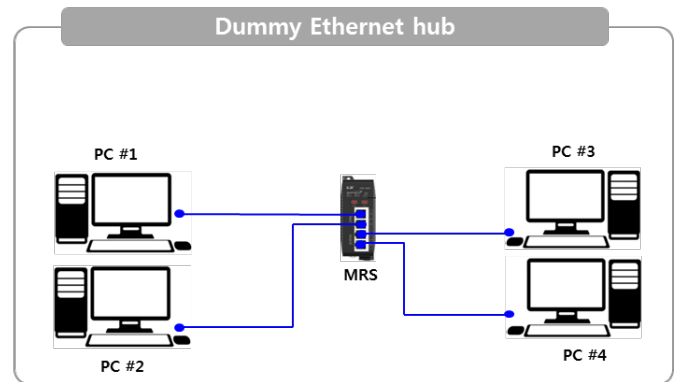
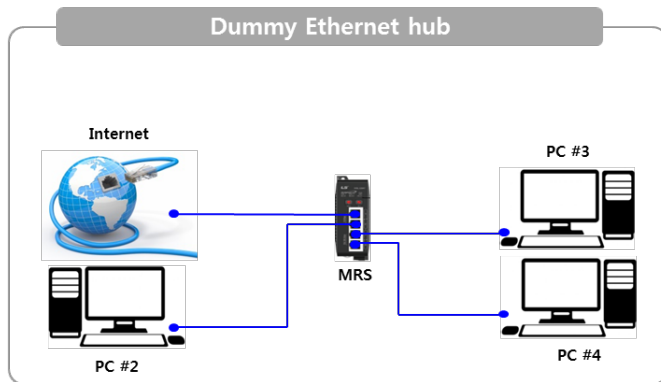
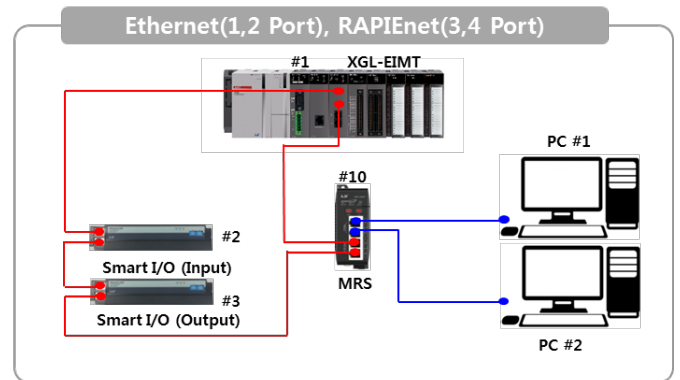
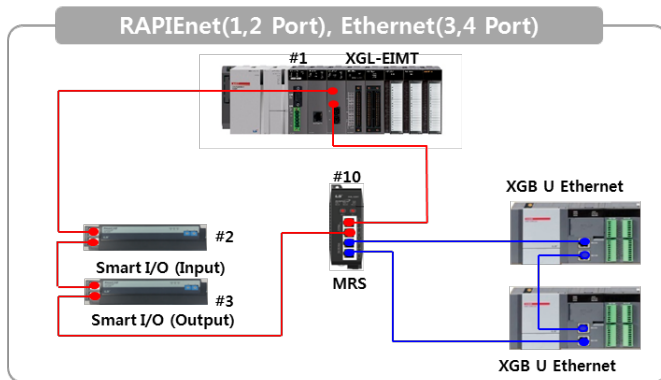

Note

- 1) The communication between RAPIenet and Ethernet is not supported.
- 2) MRS Cannot connect two MRS modules(only use 1 module in system)

Chapter 5 Communication Parameters

5.1 Introduction

The communication parameters can be classified into high speed link setting parameters and P2P setting parameters.

5.1.1 High-speed link setting parameters

The high speed link is a communication method between the XGT PLC communication modules, which is used exchange data or information at preset period. It is very useful for the systems which are operated by periodically referring the data of self or correspondent station. The communication can be set up by simply setting necessary parameters.

To set up the parameters, define the internal area and the area of the correspondent station, size and rate of data, and station number in the high speed link parameters.

The minimum data size is 1 word (16 points) and the maximum size is 200 words. Communication period can be set from 5ms to 1 second according to the contents of the communication. Communication can be implemented simply by setting parameters. Large volume of data can be exchanged periodically due to high speed internal data process.

The following table is HS link setting specification.

Parameter	Lower menu	Setting item	Range	Details
HS link	Comm. Module setting	Module type	RAPIDnet I/F	Setting module type and location
		Base	0~7	
		Slot	0~11	
	Comm. Period setting	Period type	5/10/20/50/100/200/500ms, 1s	Setting data TX period
	Emergency output data setting	CPU error	Latch/Clear	Setting output data in case of CPU error
		CPU stop	Latch/Clear	Setting output data in case of CPU stop
	Block setting	Mode	Send, Receive	
		Station No.	0~63	In case of RX, partner station number
		Block No.	0~63	
		Read area	XGT Device area	TX area
		Read are word size	1~200	TX size
		Save area	XGT Device area	RX area
	Save area word size	1~200	RX size	

[Table 5.1.1] High Speed Link parameter

5.1.2 P2P Setting Parameters

While high speed link is a periodical communication, the P2P communication is a services used to communicate with correspondent station when specific events occur. P2P can be used to transmit error information of a certain station to correspondent station, or for the communications requested by specific contact point input. While the data size used in the high speed link is word (16 points) unit, P2P communication can carry out communication with correspondent station according to the data types such as bit, byte, or word.

(1) P2P service

- (a) This service makes the RAPIEnet I/F Nodule act as a client on the network.
- (b) At occurrence of predefined events, read from or write in the memory of the correspondent station.
- (c) This service is used for the communication with other vendors' devices which do not support XGT or mode bus protocol, or transmission/reception of the desired frame.
- (d) Maximum 64 independent P2P blocks can be defined in each module.

The table below presents the specification for setting up P2P parameters.

Parameter	Sub-menu	Setting	Setting Range	Description
P2P	P2P Block	P2P function	WRITE	Transmission
			READ	Reception
		Start-up condition	Special flags, bit contact point	Set up the operational conditions of frame
		Data type	BIT	Set up the data unit of frame
			BYTE	
			WORD	
			DWORD	
		No. of variables	1~4	Set up the No. of data in the frame
	Correspondent station	Setting/Cancelling	Set up when the correspondent station is required	
	Correspondent station No.	0~63	Set up the No. of the correspondent station	
	Setting	Read area	XGT device area	Transmission area
		Storage area	XGT device area	Reception area
		Data size (XGT series)	BIT: 1 (user setting not allowed)	Size of the data to be transmitted or received
			BYTE: 1~1400 WORD: 1~700 DWORD: 1~350 LWORD: 1~175	
Data size (XGB series)		BIT: 1 (user setting not allowed)	Size of the data to be transmitted or received	
		BYTE: 1~512 WORD: 1~256 DWORD: 1~128 LWORD: 1~64		
Address	User setting not allowed (The address automatically calculated by XG5000 is set up)	The address of the N device of the CPU module where the data in the variable setting window is stored		

[Table 5.1.2] P2P Parameters

5.1.3 Comparison between high speed link and P2P

The Table 5.1.3 compares the differences between high speed link and P2P services.

The major difference is that the high speed link is for periodical communication of certain data with the correspondent station, and the P2P is for the transmission of data necessary for specific events.

Classification	High speed link	P2P
Basic data unit	1word (16 bits)	Available by data type E.g.) BIT, BYTE, WORD, DWORD, LWORD
Period	5ms, 10ms, 20ms, 50 ms, 100 ms, 200 ms, 500ms, 1s (default: 200ms)	Executed when the P2P Enable (REQ) condition is met (timer)
Available modules	Between RAPIEnet Communication Modules	Between RAPIEnet Communication Modules
Station No. designation	Set the high speed station No. (for reception) in XG5000, and download to the RAPIEnet I/F Module	Set up in the XG5000 and download to the RAPIEnet I/F Module

[Table 5.1.3] Comparison between high speed link and P2P operations

5.2 Installation and Execution of Software

In order to use the XG5000 software, you need to install the XG5000. The system specifications required for the execution are as follows.

- (1) Personal Computer and Memory
 - A set of computer with Pentium and higher CPU and 128MB and more memory.
- (2) COM Port
 - RS-232C serial port or USB port is necessary.
- (3) Hard Disk
 - At least, 100MB and more space is necessary.
- (4) Mouse
 - Mouse to connect with the computer is necessary.
- (5) Monitor
 - Monitor should have 1024 x 768 and higher resolution.
- (6) Windows
 - Compatible with Windows 2000/XP. However, XG5000 may be shut down if several applications including other programs are executed in Windows 98/ME, due to limited memory. Please execute XG5000, based on Windows 2000 or XP.

5.2.1 Installation of XG5000

- 1) Execute the installation file.
- 2) Installation Wizard will prepare for installation as below.

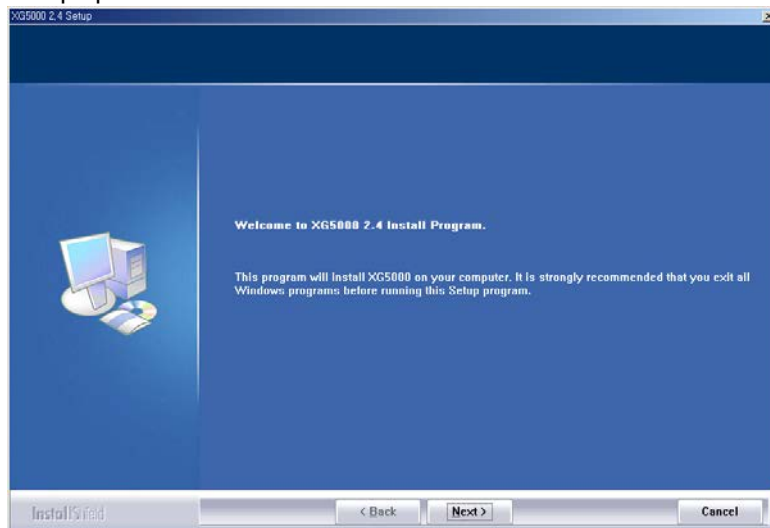

- 3) Click [Next] button, and it shows License Agreement message.
- 4) Read carefully and press [Yes]
- 5) Enter your name and company name and then click [Next] button.

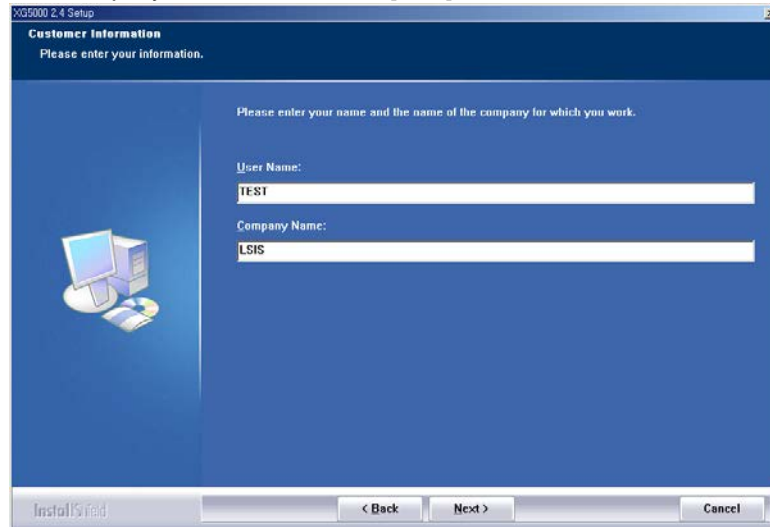

- 6) Select a folder to install XG5000 into. If you want to change the folder, click Browse... button and make or select a new folder. XG5000 needs about 30M Bytes of installation space in hard disk, which will ask you to select a disk with enough capacity. If the installation space is not enough, a warning message will be displayed to make the following progress unavailable
- 7) After a folder is selected, click [Next] button.

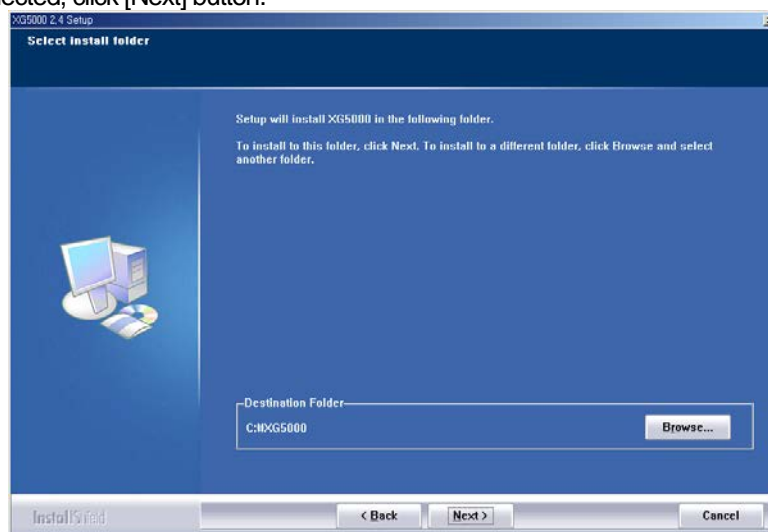

Chapter 5. Communication Parameters

8) Check installation folder and click [Next] button.

9) Installation will be started as shown below.

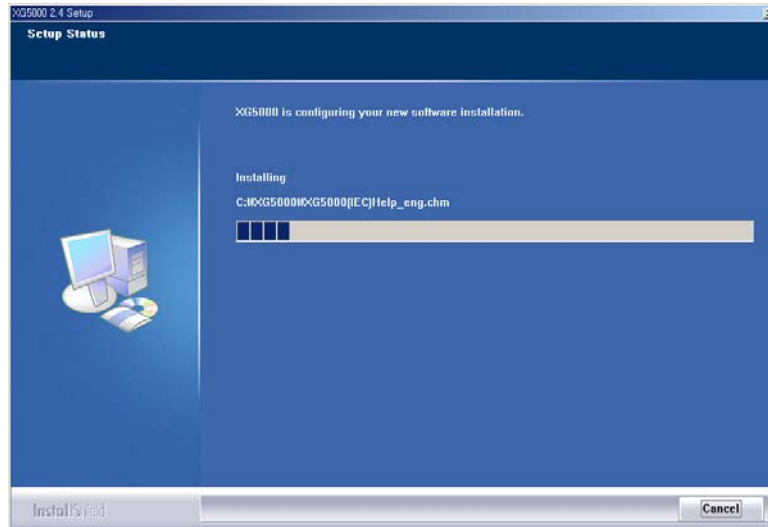

10) Wait a second for the installation to be complete.

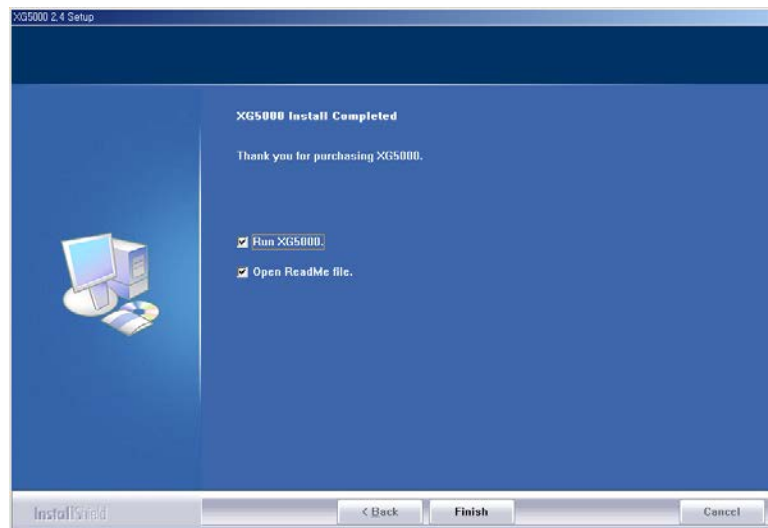

5.2.2 Installation of USB device driver

If XG5000 is installed on Windows XP for the first time, It needs USB device driver installation as an additional step. USB device driver shall be also installed as described below. If your OS is Windows 2000, XG5000 will be installed with USB device driver automatically. However, in case of Window XP, the driver shall be additionally installed.

- 1) Ensure that Drivers folder is created in the folder where XG5000 is installed, and there are 2 driver files of **GmUSBD.sys** and **GmUSBD.inf** in the Drivers folder. If there is no folder or driver file, reinstall XG5000.
- 2) Turn PLC Power on and connect USB connector with PC. If connection is established, Find New Hardware Wizard Dialog Box will be displayed to ask you to install the device driver

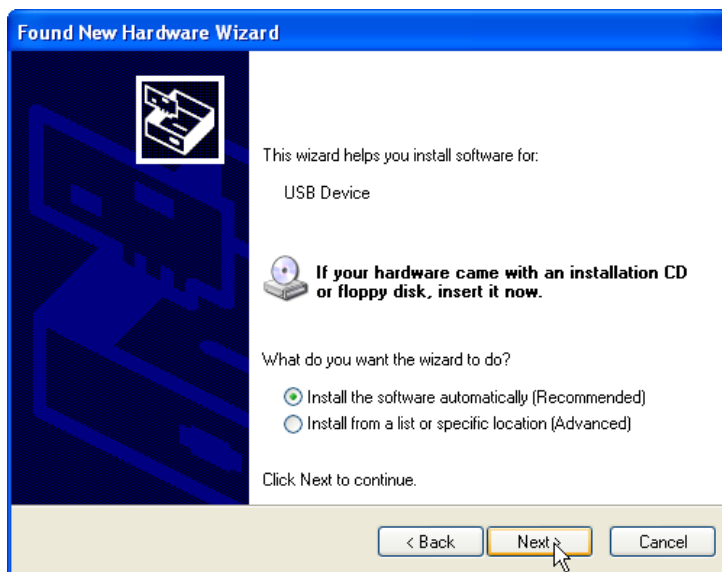

- 3) From the options of Find New Hardware Wizard Dialog Box, select “Installation from a list or specific location (Advanced)” and click [Next] to continue.

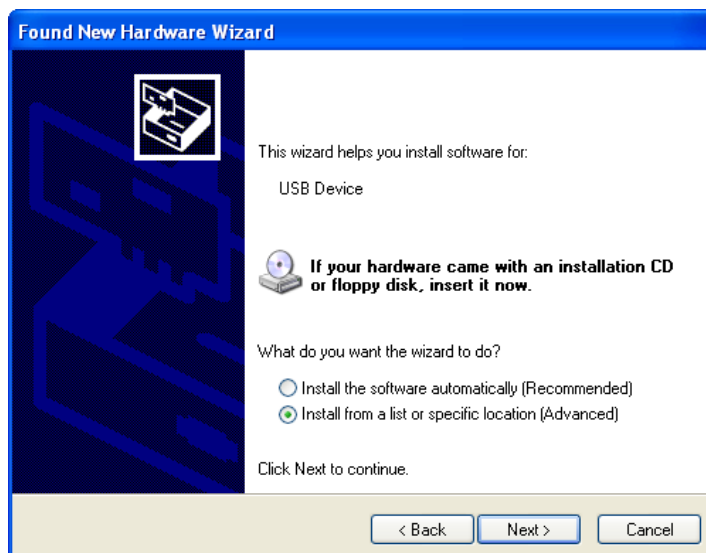

Chapter 5. Communication Parameters

- Among driver searching options, select “Search for the best driver in these locations” and check “Include this location in the search”.

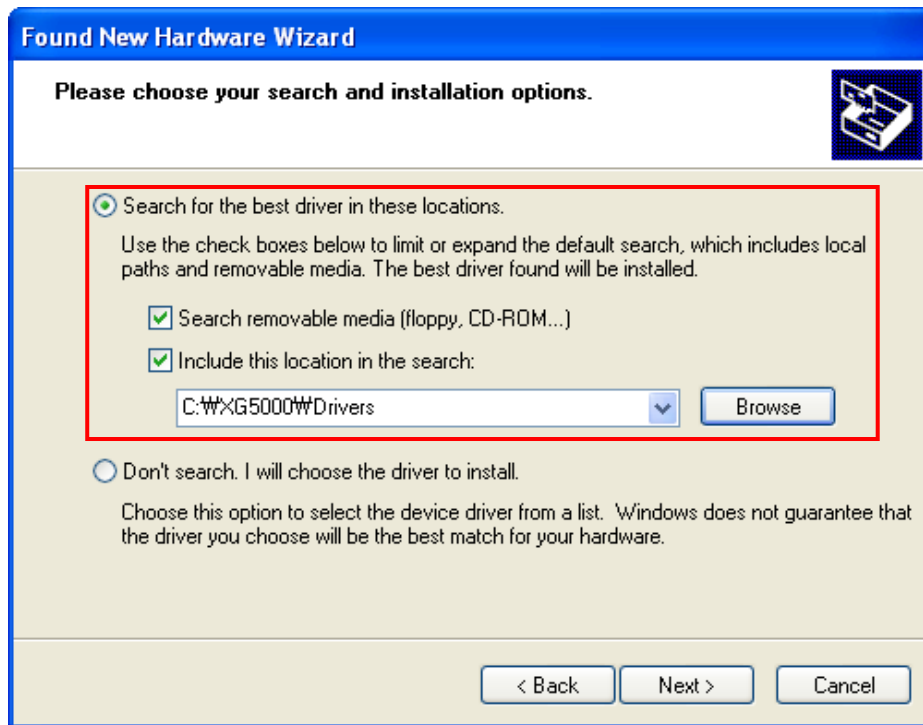

- Click [Browse] button.
On Browse Folder Dialog Box, select Drivers' folder where XG5000 is installed.

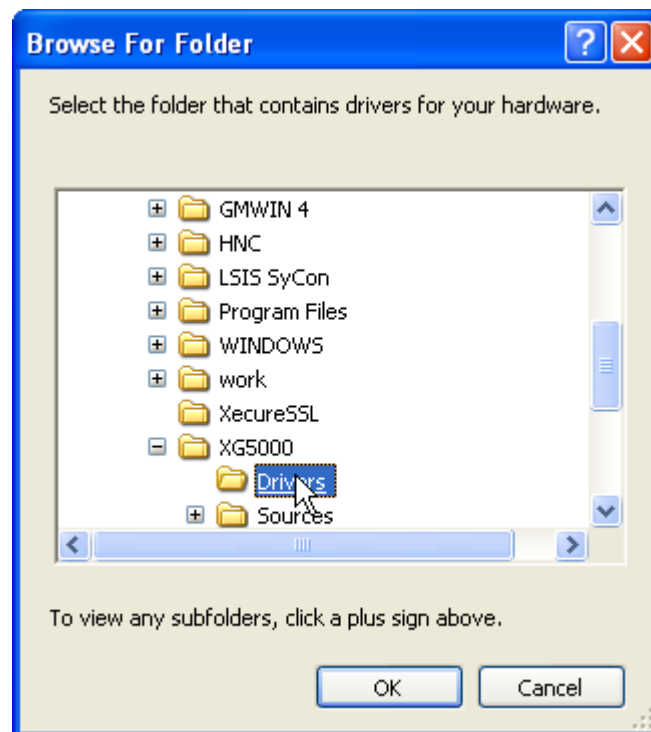

6) Click [OK] button. Then, a computer starts searching for the driver files in the selected folder.

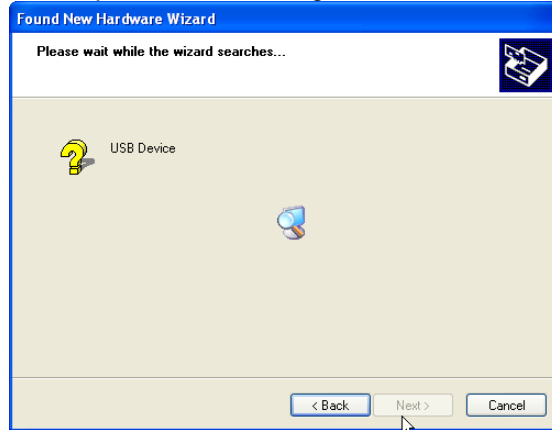

7) If the computer found the most suitable device driver, you will be asked to decide to install the selected device driver. Since USB device driver operated stably based on Windows OS, you may click [Continue Anyway] button.

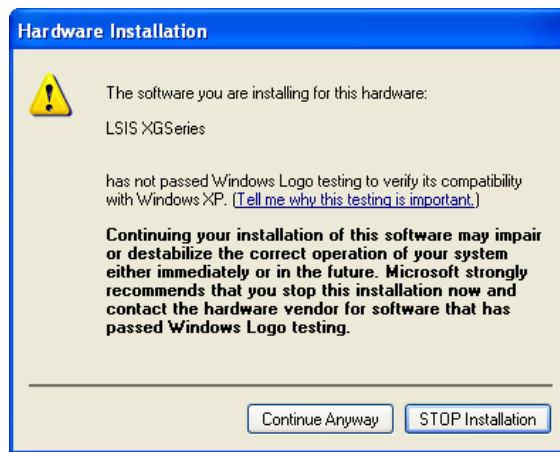

8) If the device driver has been installed completely, the Installation Complete Dialog Box will be displayed as follows. Click [Finish] button to end the installation of the driver.



5.2.3 Confirmation of installed USB device drive

If USB connection is not available, check the installation status of the device driver as follows

- 1) Click the right button of the mouse with the cursor on [My Computer] icon on the background screen, and select [Manage] on the menu.

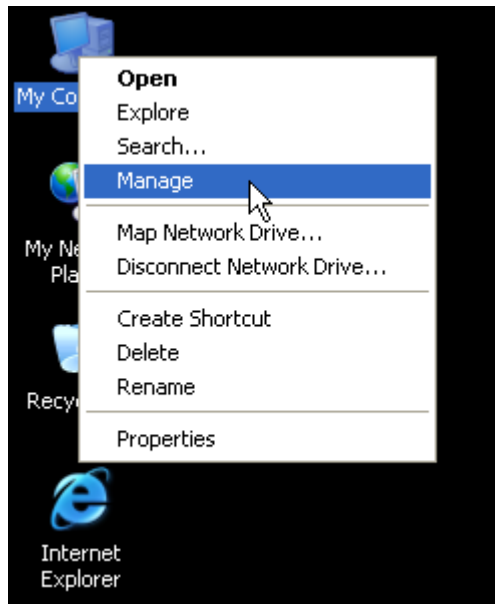

- 2) Computer Management Dialog Box will be displayed as shown in the figure below. On the left tree list of Dialog Box, click [Computer Management (Local)]-[System Tools]-[Device Manager] in regular order. The items displayed on the right list may be different according to devices installed on the computer.

(1) Normal case

The USB device driver for XGT PLC has been installed successfully, if the list [LSIS XG Series] appears with the figure under [Universal Serial Bus Controller].

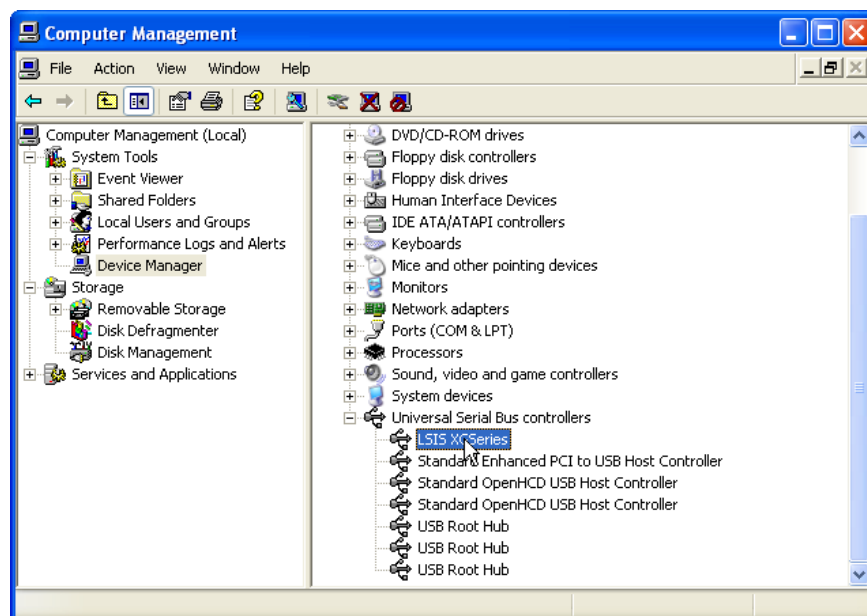

(b) Abnormal case

The device driver has not been installed successfully, if the following figure is displayed.

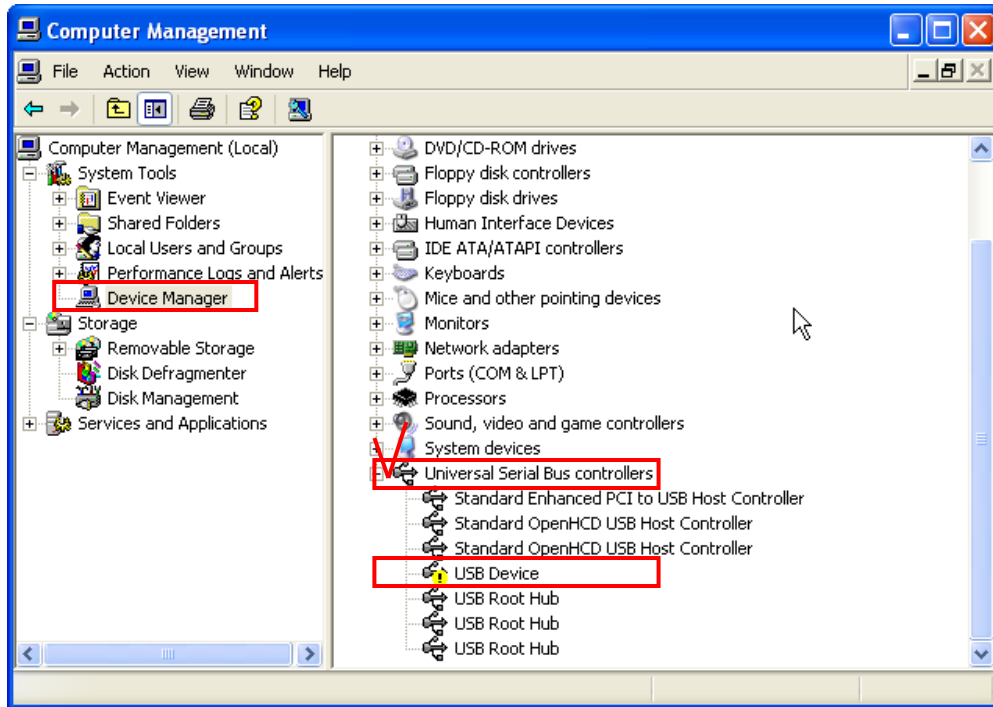

If the USB driver for XGT PLC is not installed successfully, reinstall the USB driver for XGT PLC in the following steps.

- (1) On the device driver with the icon with an exclamation mark, click the right button of the mouse. Select [Update Driver] on the menu.

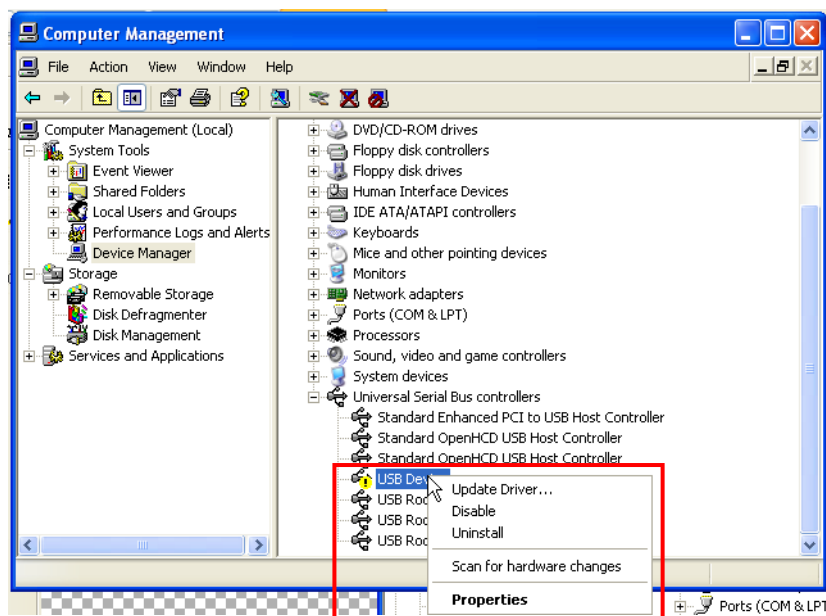

Chapter 5. Communication Parameters

- (2) H/W Update Wizard Dialog Box will appear. Select the option “Installation from a list or specific location (Advanced)” and click [Next]. The next sequence is manually the same as in Installation of Device Driver.

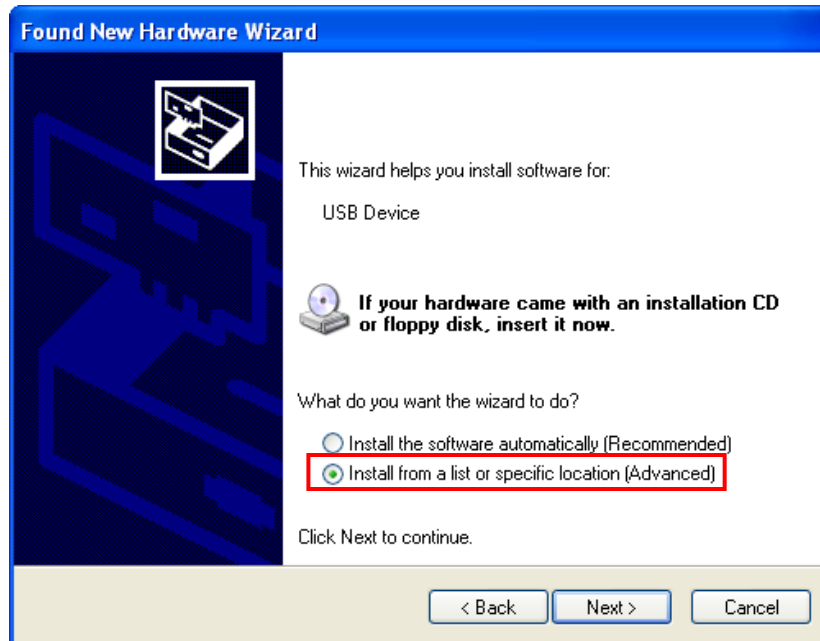

If the USB driver for XGT PLC is not installed successfully, reinstall the USB driver for XGT PLC in the following steps

- (1) If the device driver has been installed incorrectly or in error, execute H/W Update Wizard.
- (2) Select the option “Installation from a list or specific location (Advanced)” and click [Next].

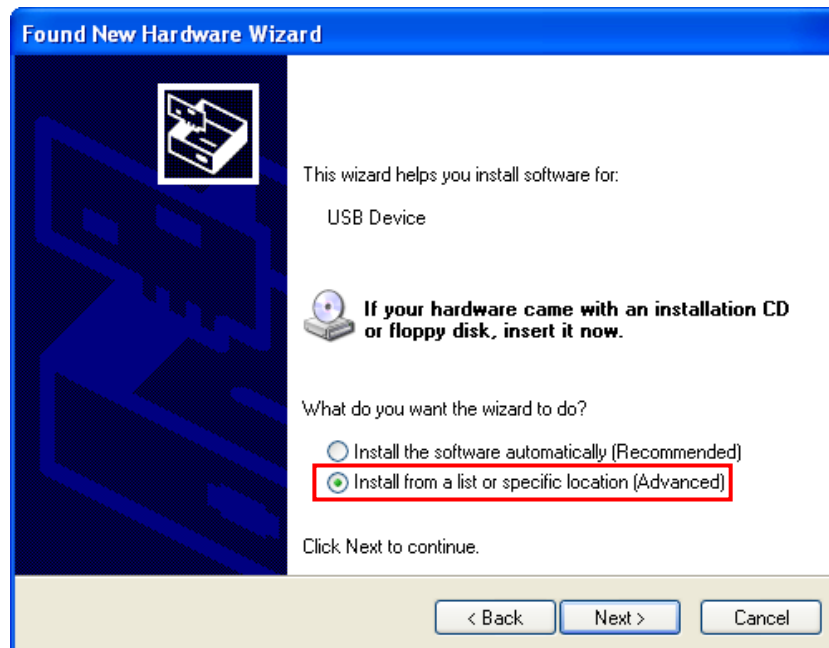

(3) On search and installation options, select [Don't Search. I will choose the driver to install.] and click [Next]

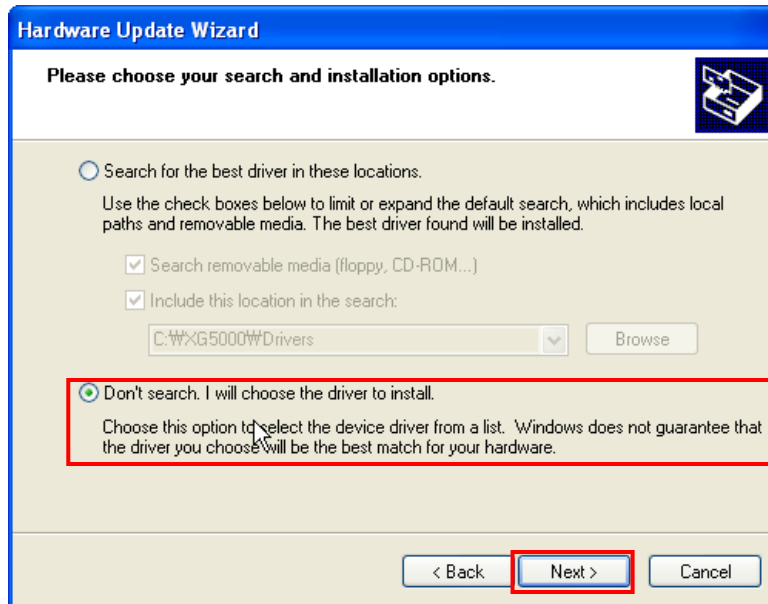

(4) Click [Have Disk...] on the Dialog Box below

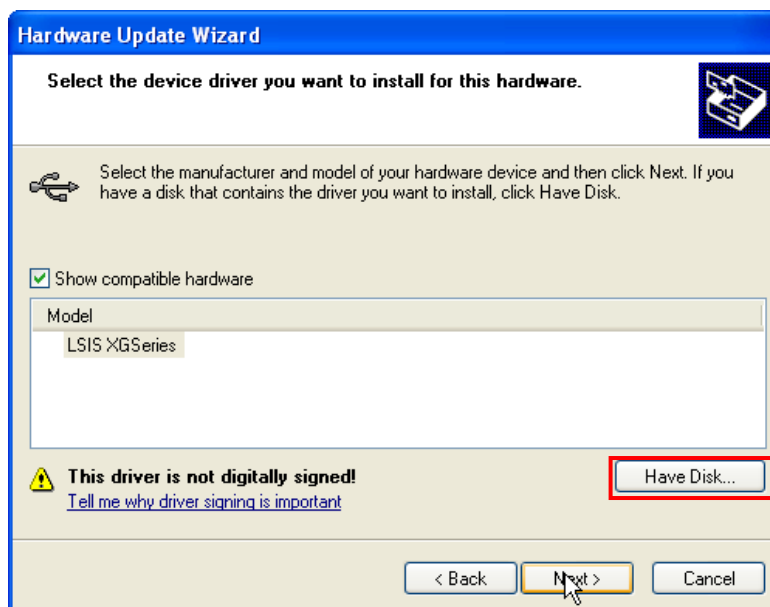

Chapter 5. Communication Parameters

(5) If Installation Dialog Box is displayed on the disk, click [Browse] button.

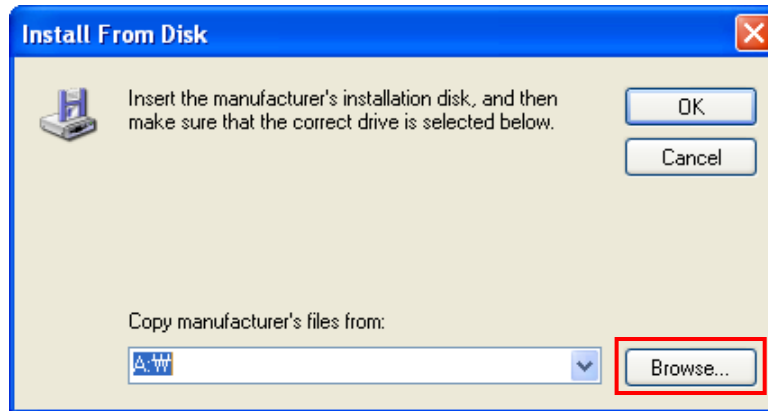

(6) From the Browse File Dialog Box, move to the folder XG5000 is installed in. Select drivers folder to display GmUSBD.inf file. With this file selected, click [Open] button.

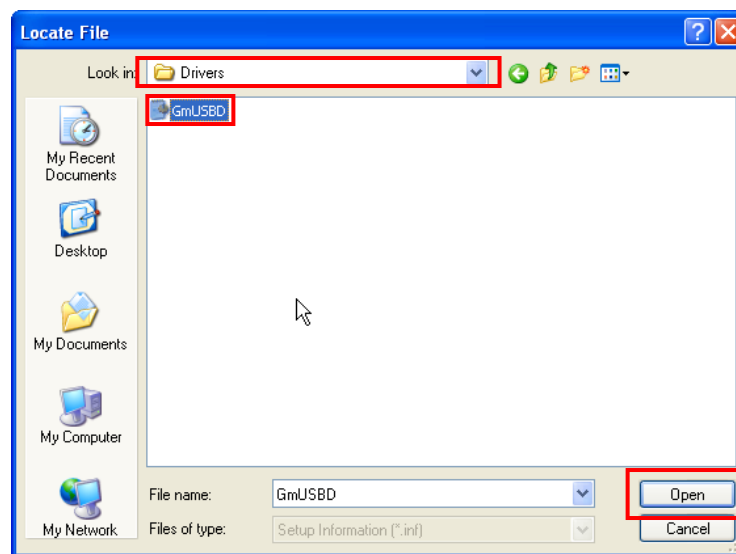

(7) On the item of 'Copy manufacturer's files from', a directory with the file of the device driver will be displayed. Click [OK] button

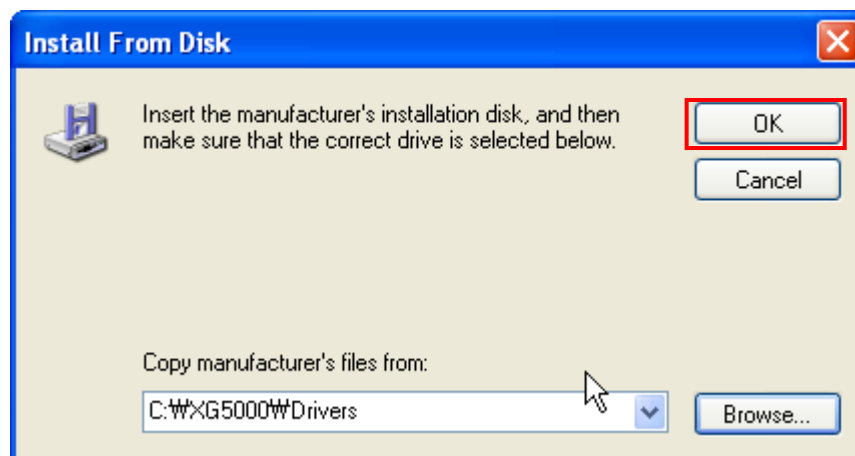

- (8) On 'Show compatible hardware' list of the device driver Select Dialog Box, select "LSIS XGSeries" driver and then click [Next] button

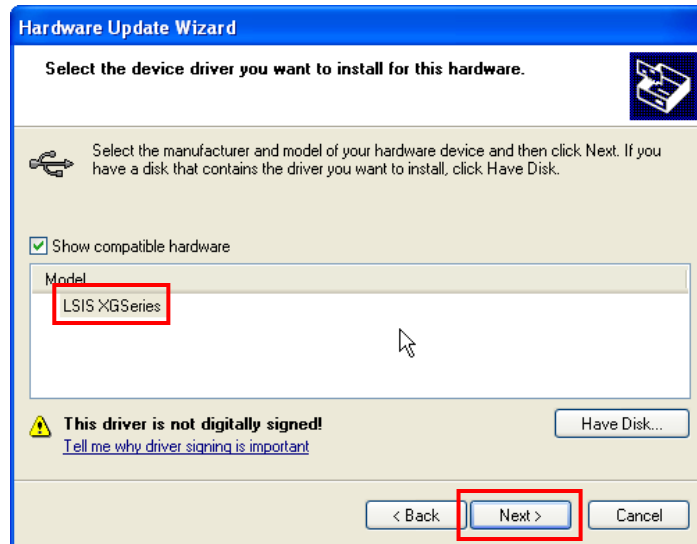

- (9) Hardware Installation Dialog Box will appear. Click [Continue Anyway] to go on with the installation



- (10) Completing the Hardware Update Dialog Box will appear. Click [Finish] button to end the installation of the driver

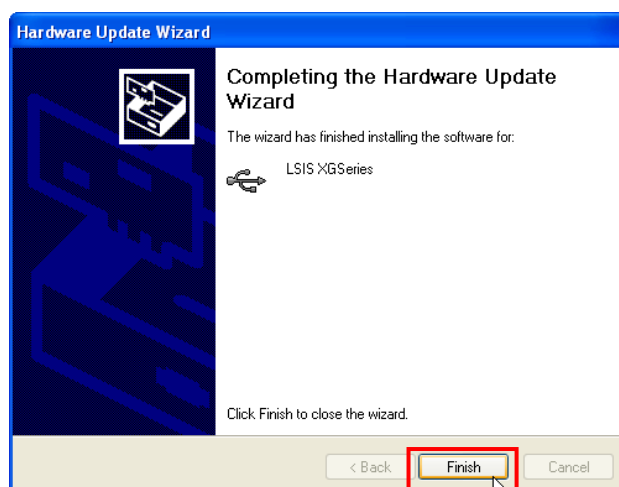

5.3 Registration of Communication Module

In order to use RAPIenet I/F module, communication parameters shall be specified in XG5000. And for system setting of Cnet I/F module positioned at an optional place, its applicable module shall be registered in XG5000. How to register the optionally positioned RAPIenet I/F module depends on On/Off line status as described below.

5.3.1 Off-line registration

This method is used when the user writes the parameter related with communication about communication module that is not connected with PLC.

- (1) Execute the XG5000 and select [Project]-[New Project] or click the icon ().
- (2) Input the project name, file location and PLC type the user is using.

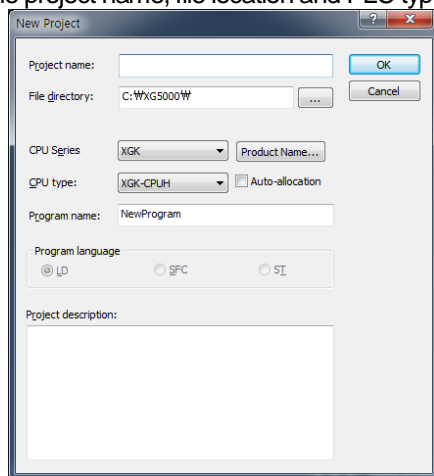

- (3) Adding communication module without connect to XGT, Use “Select Communication module” window. In case of adding RAPIenet at Base0-Slot3, please follow as below

- a) Right click on the ‘Unspecified Network’ in project tree, select [Add Item]-[Communication module]

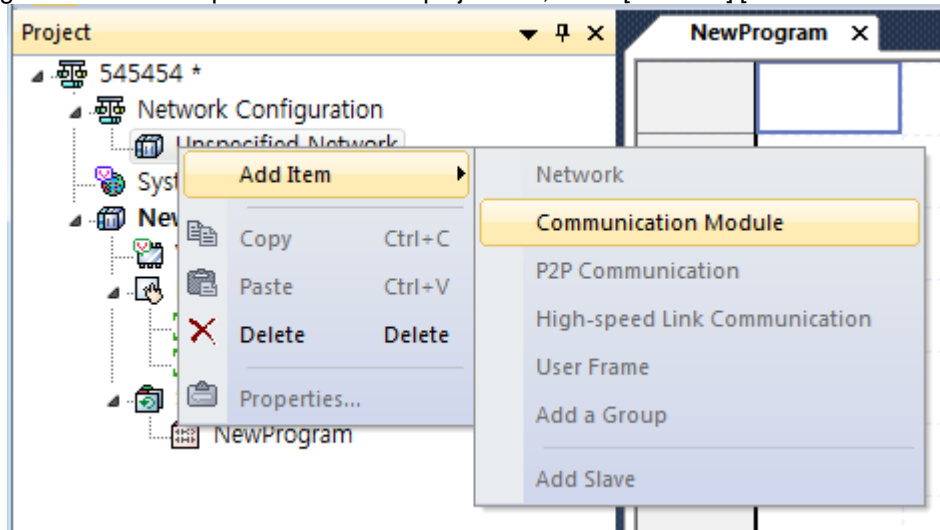

b) Click “Add Module”.

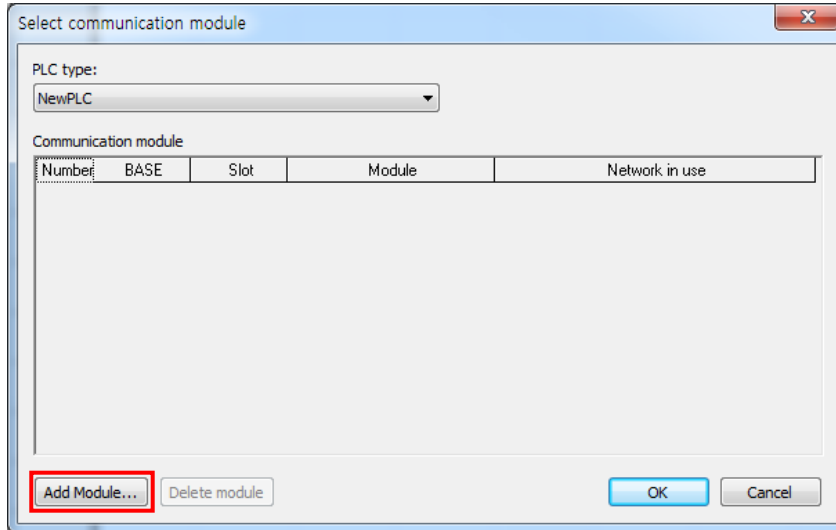

c) Select communication type, base, slot. Then click “OK”.

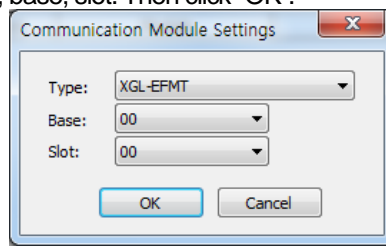

Screen of add RAPIEnet I/F in base0-slot3 is below

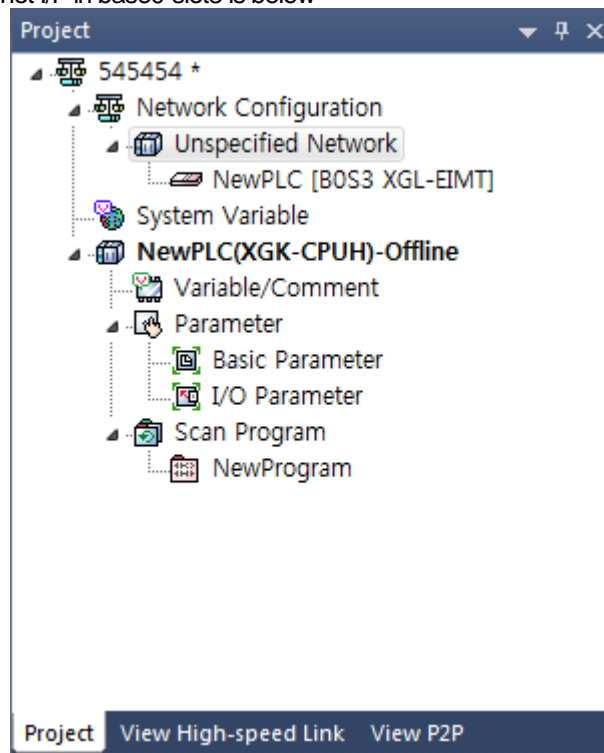

5.3.2 On-line registration

Step (1), (2) of off-line registration is same and the next step is as follows.

- (1) Input the project name, file location and PLC type the user is using.
- (2) If connection fails, check the connection status. Select [Online] – [Connection settings] or click the icon (). There are many connection types (RS-232C, USB, Ethernet and modem) and depths (Local, Remote 1, Remote 2). For remote connection, refer to the Chapter 8 Remote Connctcion.

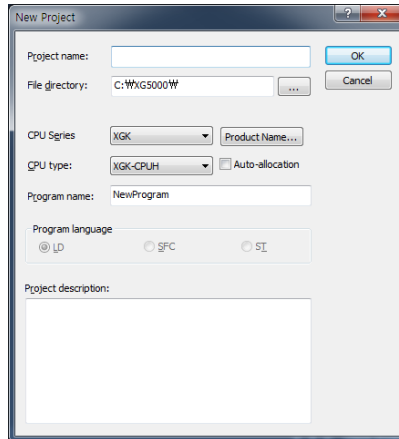

- (3) If connection succeeds, lower menu of online is activated.
- (4) In order to check the currently mounted modules, select [Online] – [Read IO Information] or click the icon (). Then all currently mounted communication modules in the basic and extension bases are searched and shown in the Project window.
- (5) If previous information of mounted module is different with currently mounted PLC information, the following message shows to check.

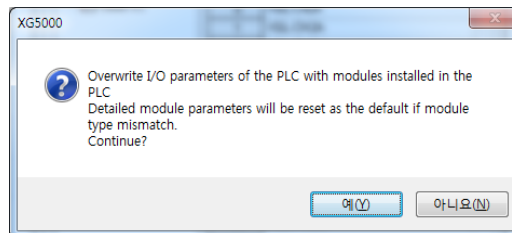

- (6) The list of the mounted communication module shows in the Project window.

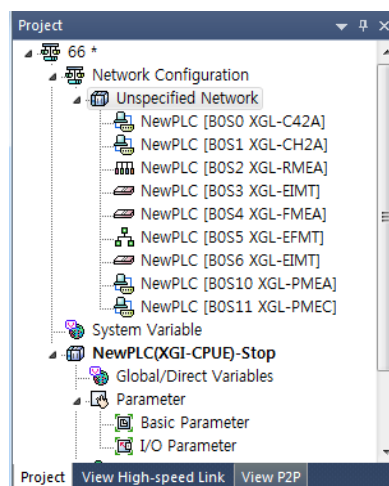

5.3.3 How to read the parameter saved in the PLC

To read the parameter saved in the PLC, follow the below sequence.

- (1) Select the 'Open from PLC'.

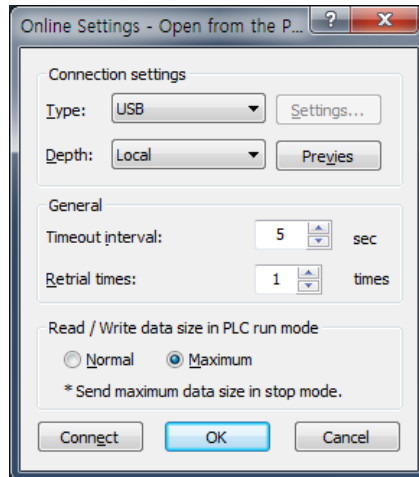

- (2) The user can check the setting value of standard settings and P2P saved in the PLC.

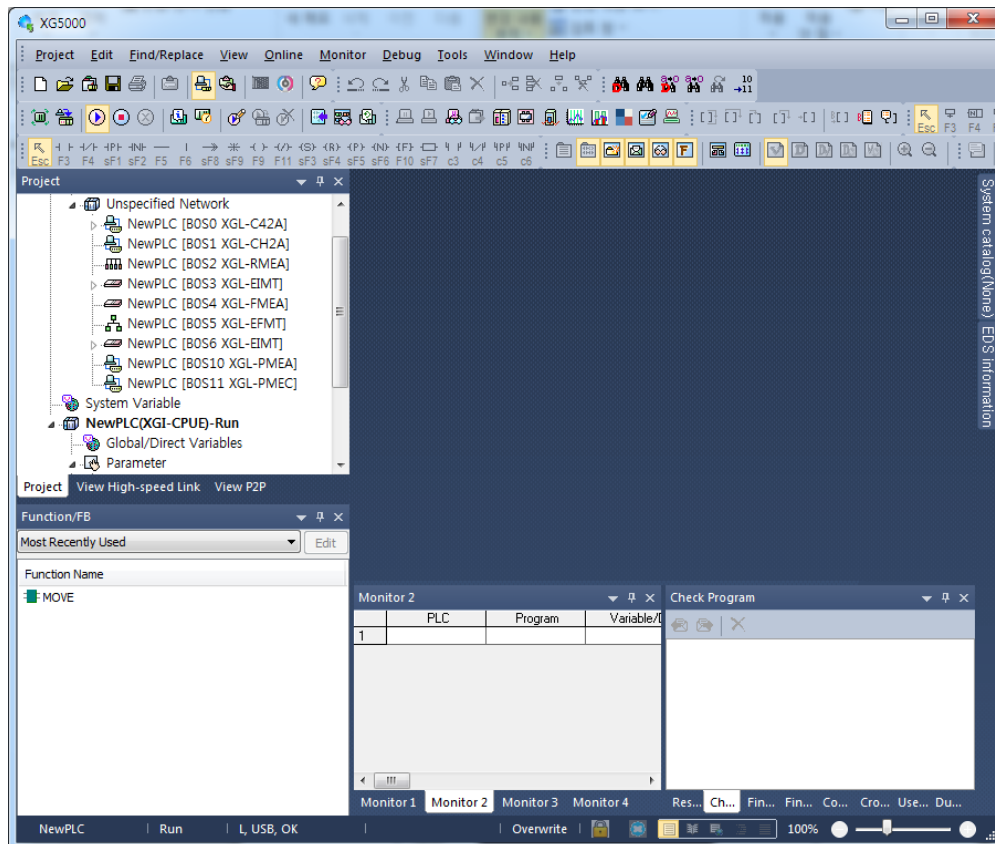



Chapter 5. Communication Parameters

5.3.4 Module setting method

To use RAPIenet I/F module., set as the following steps

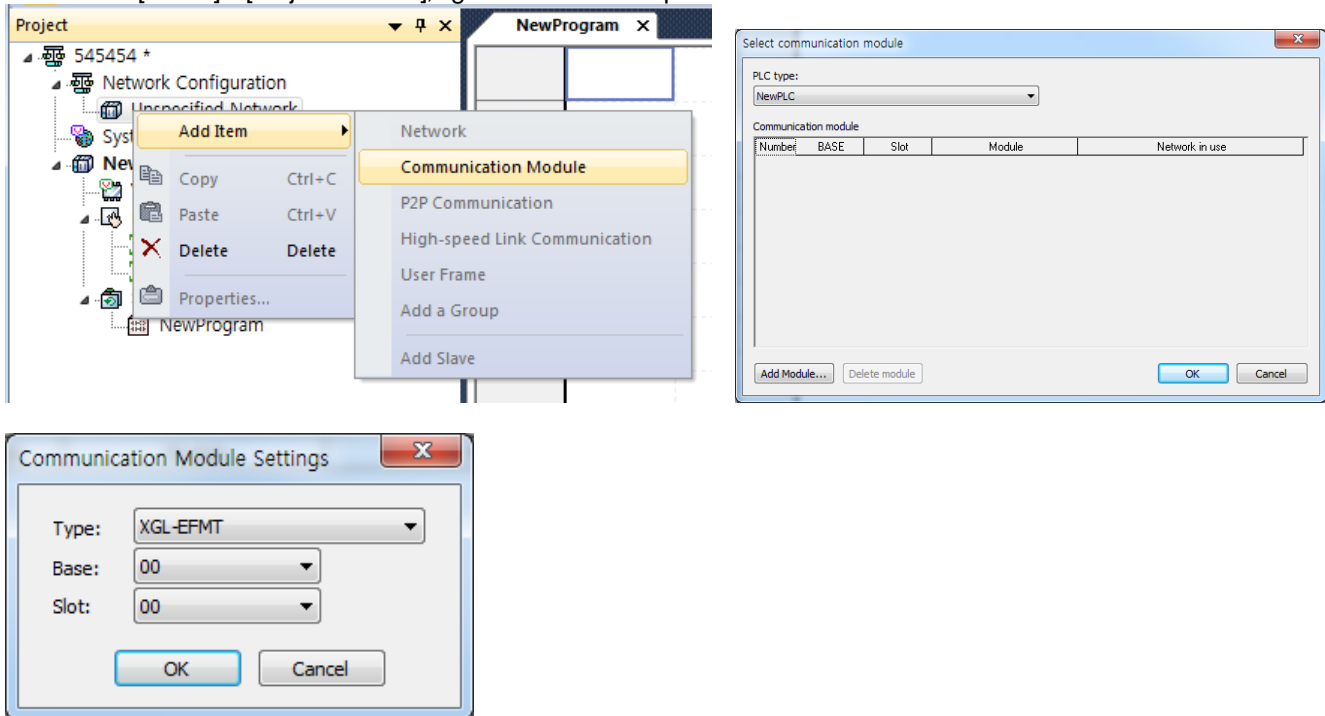
- (1) Direct input in project window
[Online] – [Project Window], right click on the 'Unspecified Network' -> Add Item -> Communication Module



- (2) Read I/O Information
Read the IO information of the currently mounted modules by [Online]-[Diagnosis]-[I/O Information] and click "I/O Sync" after connection.
- (3) Checking the operation
 - (a) Select [Online]-[Communication module setting]-[System Diagnosis] or click the icon ().
 - (b) Click the right button at the releavet module and click the "Status By Service" to check the communication.

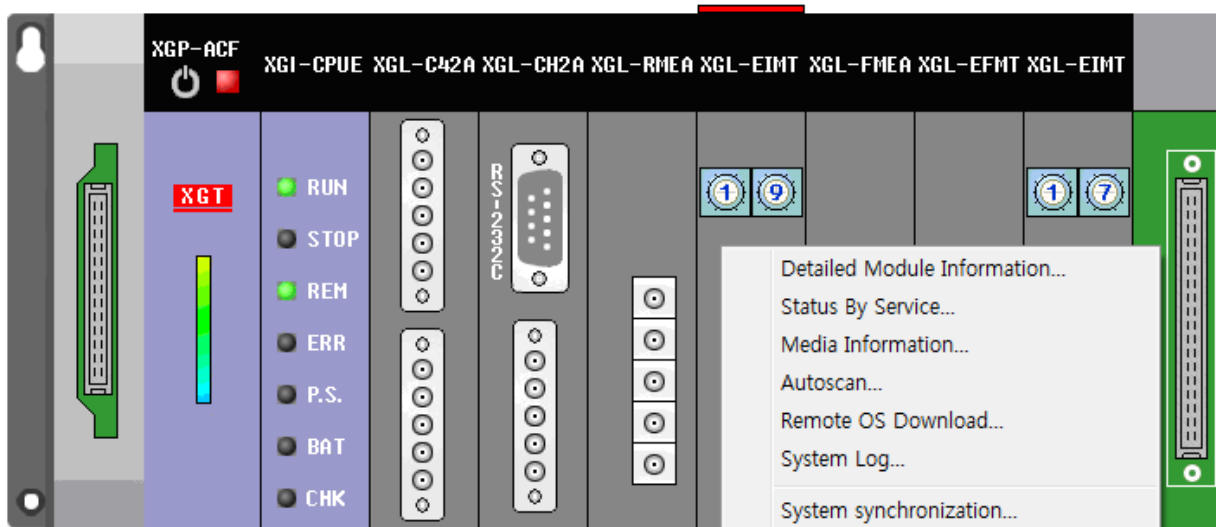









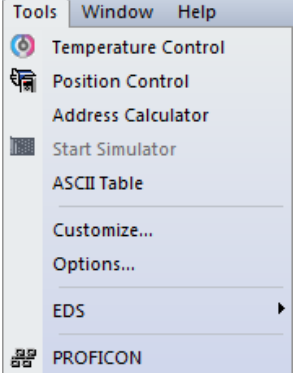

5.3.5 Menu bar and shortcut of XG5000

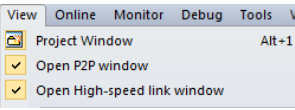
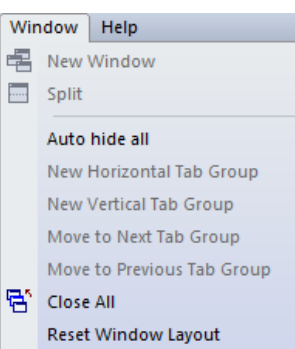
The following is menu bar and short cut of XG5000.

Menu bar		Menu	Icon	Description
Project		New Project		Create a new project.
		Open Project		Open the existing project.
		Open from PLC		Upload the project and program stored in PLC.
		Open KGLWIN File		Open the project file for KGLWIN.
		Open GMWIN File		Open the project file for GMWIN.
		Save Project		Save the project.
		Save As	-	Save the project as a different name.
		Close Project		Close the project.
		Save As Binary		Saved as the binary file that cannot show the details of the project.
		Write Binary to PLC		Write the binary file with the PLC. You cannot see the details of the project.
		Add Item		Add Item to Project
		Import from File		Import the item from the file to the project
		Export to File		Save the selected items included opened project as separated file.
		Save Variable Names to File		Save variable names to file for using other programs.
		Save EtherNet/IP Tags to file		Register EtherNet/IP tag and save the established EtherNet/IP tag list to the file.
		Compare Project		Compare two projects stored in PC and displays its result.
		Print		Print the active window's details.
		Preview	-	Previously display the screen to be printed.
		Print Project	-	Select the project item to print
		Print Setup	-	Set the printer options.
Edit		Undo		Cancel the edit on Program Edit Window to recover its previous status.
		Redo		Recover the edit cancelled above.
		Cut		Copy the selected block to clipboard and delete the block.
		Copy		Copy the selected block to the clipboard.
		Paste		Copy from the clipboard onto Edit Window.
		Delete		Delete the selected block or items.
		Register Module Variable Comments Network variable automatic registration Read Only Mode		
Online		Connect		Connect with PLC
		Connection Setting		Specify the connection method.
		Change Mode		Change the mode of connected PLC
		Read		Read parameter/program/comment from PLC.
		Write		Write parameter/program/comment on PLC.
		Compare with PLC		Compare the project with project saved in PLC
		Set Flash Memory	-	Shows the window for setting up the flash memory.
		Control Redundancy		Control the redundancy PLC.
		Communication module setting		Set about communication module
		Reset/Clear		Reset the PLC or delete the data

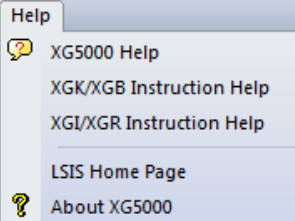
Chapter 5. Communication Parameters

Tools		Temperature Control		Execute the XG-TCON tool.
		Position Control		Execute the XG-PM tool.
		Address Calculator		Open Address calculator
		Start Simulator		Start simulator
		ASCII Table		Open ASCII Table
		Customize		Open customize windows
		Options	-	Open XG5000 option windows
		EDS		Manage EDS file
		PROFICON		Oper PROFICON
		View		Project Window
Open P2P window	-			Open P2P window to XG5000
Open High-speed link window	-			Open HS window to XG5000
...	-			The Following description, please refer to the XG5000 user's guide.
Window		New Window		Open a new window on the active window.
		Split		Divide the active window.
		Auto hide all		Hide all windows automatically except current windw
		New Horizontal Tab Group		Arrays the several windows belonging to XG5000 with the horizontal tab
		New Vertical Tab Group		Arrays the several windows belonging to XG5000 with the vertical tab.
		Move to Next Tab Group		Move to the next tab group.
		Move to Previous Tab Group		Move to the previous tab group.
		Close All		Close all windows belonging to XG5000.
		Reset Window Layout	-	Reset the default layout of the project.
		Help		Help
LSIS Home Page				Connect to LSIS Home Page via the Internet.
About XG5000				Shows XG5000 information.

5.4 How to set the parameter according to service

5.4.1 High-speed link service

HS link as a communication method between XGT PLC communication modules is used to exchange data or information with correspondent station periodically for a specific time, through which the changed data of self station or the correspondent station can be referred to for each other periodically for efficient application to the operation system and execution of communication only with simple parameters setting.

Parameters can be specified by setting Tx/Rx correspondent station area and self station area as well as data size, speed and station No. on XG5000's HS link parameters in order to execute communication.

Data size is available from the min. 1 word (16 points) up to 200 words for the communication, communication cycle from the min. 20 ms up to 10 sec. based on the communication details. It is easy to use since communication with correspondent station is available only through simple parameters setting. And it is also useful for periodic process of lots of data at a time thanks to high processing speed of the internal data.

(1) Communication module configuration

In order to use the high speed link, set up communication module and high speed link using the XG5000, and download the setting to the CPU.

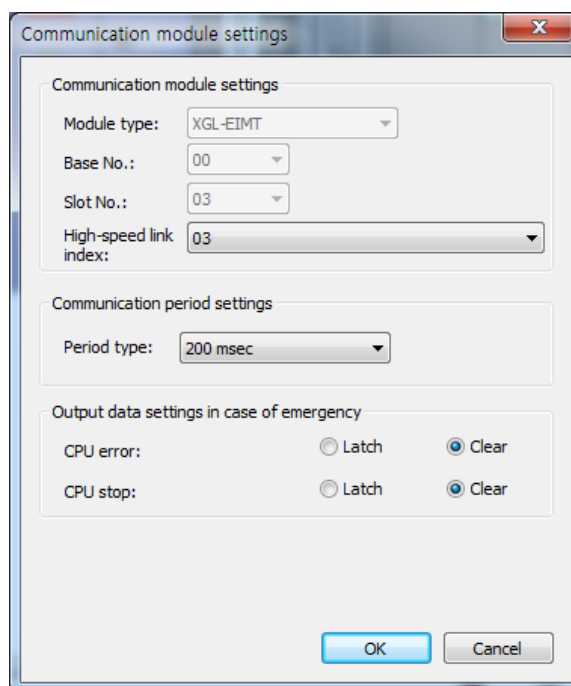

(a) Module type: PLC2PLC(RAPIEnet)

(b) Base No./slot: position of installation of the communication module

(c) Communication period setting

- Transmission period can be set from 5ms to 1s, improving the overall efficiency of communication.

(d) Emergency output data setting

- CPU error: at CPU error, check whether the transmission data information clear is set up or not

- CPU stop: at CPU switching to stop, check whether the transmission data information clear is set up or not

Chapter 5. Communication Parameters

(2) Block setting

Index	Mode	Station number	Block number	Module type	Read area	Read area Word size	Save area	Save area Word size	Diagnostic information device
0	Send		0	RAPIDnet	%MW0	2			
1	Receive	17	0	RAPIDnet			%MW10	2	
2	Send		1	RAPIDnet	%MW1100	50			
3	Receive	2	1	RAPIDnet			%Mw1500	50	
4									

...

126									
127									

(a) Mode: transmission/reception

(b) Station No.: set up correspondent station No. for receiving only

(c) Block No.

This parameter is for communicating large volume of data in multiple areas of a station, by classifying the data in multiple blocks. The station No. and the block No. set up at the transmission station are transmitted with the data, and at the receiver station, data is stored in the storage area when the station and block numbers are same as those set up in the high speed link parameters. Therefore, the block numbers have to be set at both transmission and reception station together with the station number. The block numbers can be set as many as 64 from '0' to '63' for each station.

- Do not allocate multiple block numbers under the same station number.
- 200 words can be set to one block. The maximum link points are 12,800 words.
- The serial No. representing the order of registration, from '0' to '127,' not in relation with the order of communication.

(d) Read area: enabled when the block type is transmission. This is the area setting of the device for transmission

(e) Storage area: enabled when the block type is reception. This is the area setting of the device for reception.

(f) Data size (word): can be set by 1 ~200. If the data size set up in the reception mode is smaller than that of the data received, the excess data is not stored. Therefore, only necessary volume of data can be received selectively from the transmitter station for use.

(3) Writing high speed link parameter

Select 'Write Parameter' from the Online menu. In the Write Parameter window, check the respective high speed link and click Confirm button.

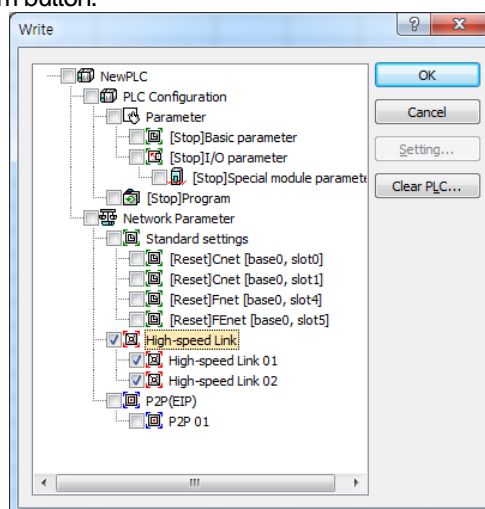

Note

1) In case of XGB, 0~63, total 64 HS link block can be set and it is nothing with TRX order.

(4) Read high speed parameter

Select 'Read Parameter' from the Online menu. Check the desired parameter and click Confirm button to read the high speed link parameter.

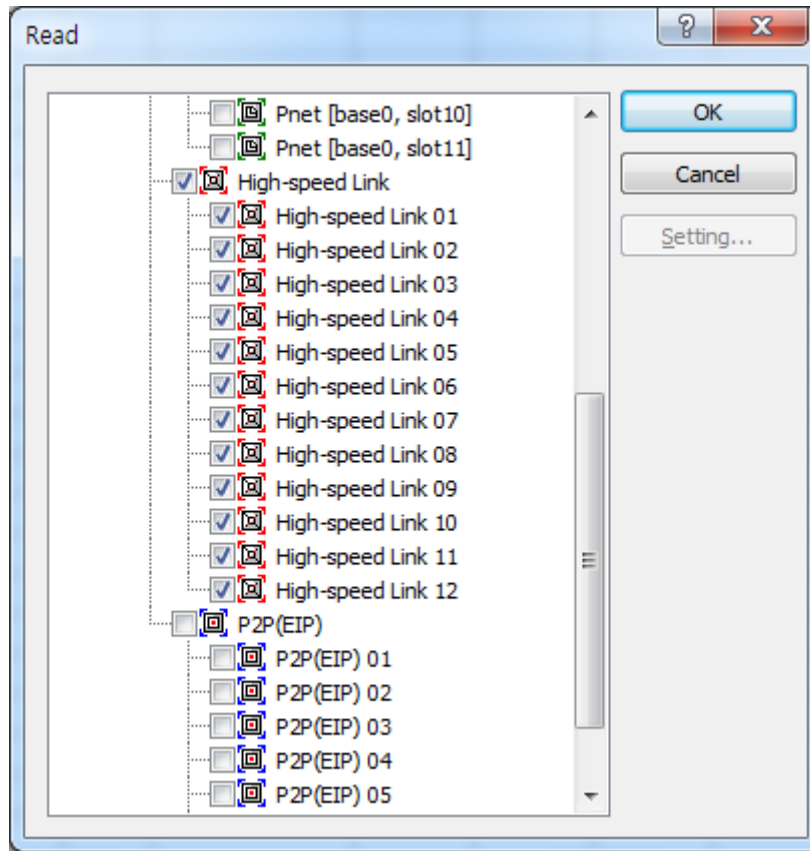

(5) High speed link information

The high speed link information is provided to the XG5000 user as user keyword for use in programming.

Type of high speed link flags

	Variable	Type	Device	Comment
1	_HS1_RLINK	BIT	L000000	All stations are OK in HS link 1
2	_HS2_RLINK	BIT	L000500	All stations are OK in HS link 2
3	_HS3_RLINK	BIT	L001000	All stations are OK in HS link 3
4	_HS4_RLINK	BIT	L001500	All stations are OK in HS link 4
5	_HS5_RLINK	BIT	L002000	All stations are OK in HS link 5
6	_HS6_RLINK	BIT	L002500	All stations are OK in HS link 6
7	_HS7_RLINK	BIT	L003000	All stations are OK in HS link 7

5.4.2 P2P Service

P2P service acts as the client of the communication module. This service can be used by setting the XG5000 parameters. Up to 8 P2P parameters can be set up. Each P2P parameter consists with maximum 64 P2P blocks. Major functionalities of the P2P service are listed below.

- (a) The functions of program which have been carried out by PLC are executed by the communication module.
- (b) Programming is carried out by setting the parameters in the XG5000.
- (c) Using memory transmission method, when function change or addition is required, the functions can be changed or added by changing the OS of the XG5000 and communication module, without changing the OS of the CPU module.
- (d) Modification during running can be done by adding, changing, or deleting individual parameter block.
- (e) Maximum 64 parameter blocks can be monitored.

Index	P2P function	Conditional flag	Data type	No. of variables	Destination station	Destination station number	Setting	Variable setting contents
0	WRITE	F00099	WORD	1	<input checked="" type="checkbox"/>	2	Setting	Number:1READ1:K0500,SAVE1:ZR00000,SIZE1:1
1	READ	F00099	WORD	1	<input checked="" type="checkbox"/>	4	Setting	Number:1READ1:M0500,SAVE1:K0200,SIZE1:1
...								
62					<input type="checkbox"/>		Setting	
63					<input type="checkbox"/>		Setting	

[Fig 5.4.2] Example of P2P parameter setting

P2P service provides read and write functions to support reading and writing of the partners memory.

P2P Function	Description	Remark
READ	Read the area defined in the partner memory and save the read data.	-
WRITE	Save a part of PLC memory in the area defined in the partner.	-

- ▶ P2P parameter setting window
 - ▷ Maximum 8 P2P parameters can be set up
 - ▷ Multiple P2P parameters can be set up for one RAPIEnet I/F Module
However, the Enable is allowed only for one of the P2P parameters for one RAPIEnet I/F Module
- ▶ P2P edit window
 - ▷ maximum 64 P2P blocks can be registered and edited.

Note

1) In case of XGB, max. block number of P2P parameter is 32. Up to 2 P2P parameter settings are available.

5.4.3 MRS parameters setting

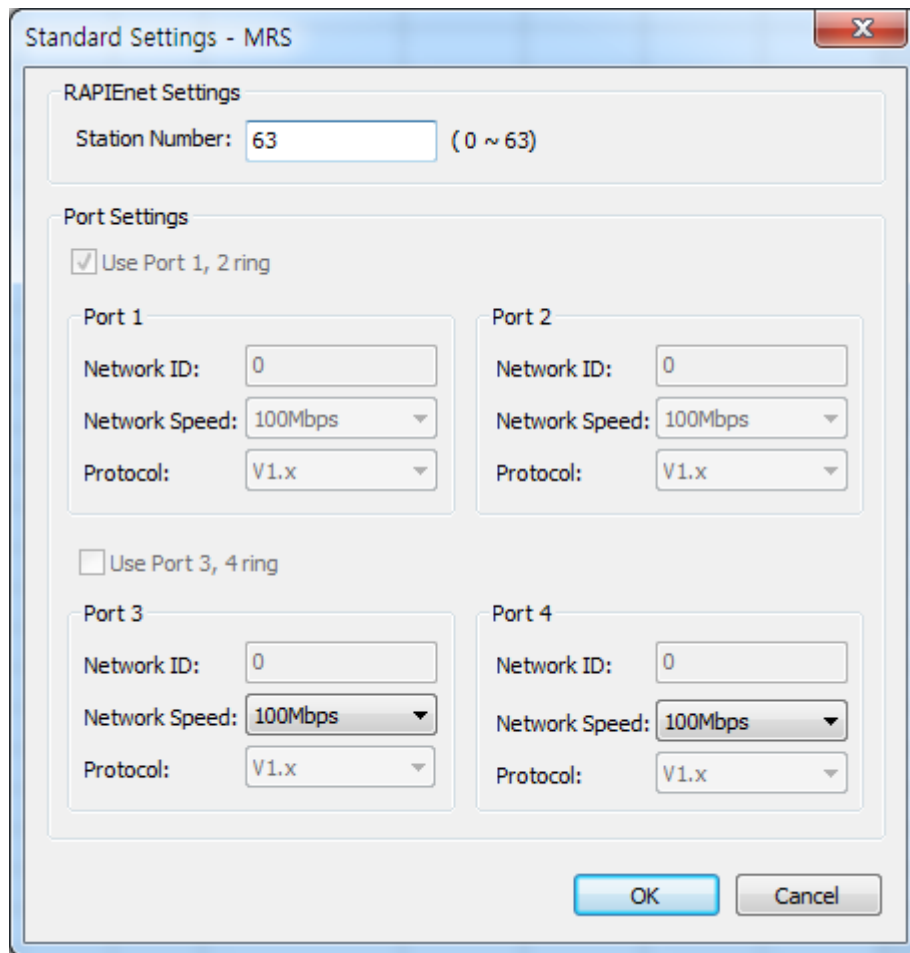

The table below presents the specification for setting up parameters.

Item	Enable or Disable	Contents	Note
Station Number	Enable	Setting Station number	Can choose 0~63
Port 1,2 Use Ring	Disable	Port 1, 2 is used to Ring topology.	Setting port 1, 2 Separately (provided further)
Port 3,4 Use Ring	Disable	Port 3, 4 is used to Line topology.	Setting port 3, 4 Separately (provided further)
Port x Network ID	Disable	Setting Network ID	Provided further
Port x Network speed	Enable	Select Auto, 1000Mbps, 100Mbps	
Port x Protocol	Disable	Setting compatible RAPIEnet version	Provided further

[Table 5.1.4] Basic parameter

5.5 Operation Start-up

RAPIDnet I/F module's operation is divided into P2P service and High-speed link service generally. When setting the RAPIDnet I/F module as server, follow the 6.3 and when setting the RAPIDnet I/F module as P2P service, follow the Chapter 7 about parameter setting

5.5.1 XG5000 setting

(1) Overview

This tool defines basic system parameters for the control and management of network in PLC2PLC communication, and the basic configuration of communication. In the XG5000, it is divided into the high speed link and P2P communications which defines the communication system parameters for the PLC2PLC communication module. The parameters set up by user can be written (downloaded) in the RAPIDnet I/F communication module and read (uploaded) from the RAPIDnet I/F communication module.

(2) Connection setting

- (a) Select [Online]-[Connection settings] or click icon ().
- (b) After setting the connection option according to user, click the 'connection'.

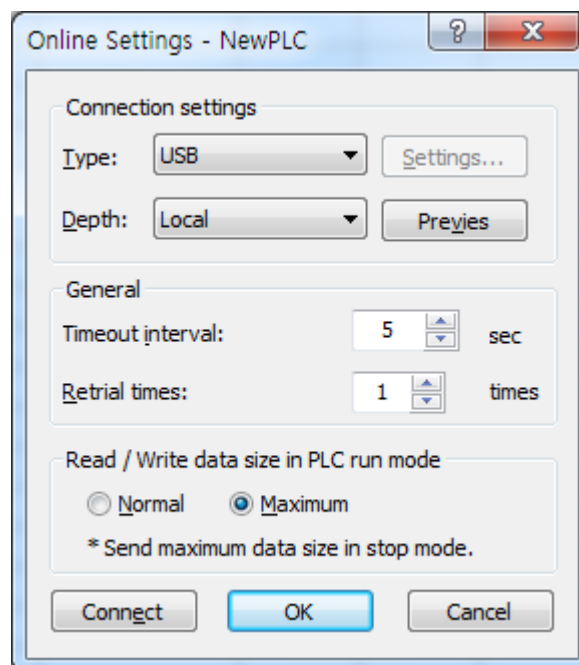

(3) Reading IO information

Select [Online]-[Diagnosis]-[I/O Information] and click "I/O Sync". Then IO information of currently mounted is shown on the project window.

(4) Basic setting

The RAPIDnet I/F Module needs no basic setting. In order to register the RAPIDnet I/F Module on the basic setting window, install the RAPIDnet I/F Module in the slot, reset system, access the system with XG5000 and select 'Read IO Information.' As shown in [Fig. 5.5.1], the RAPIDnet I/F Module appears on the window.

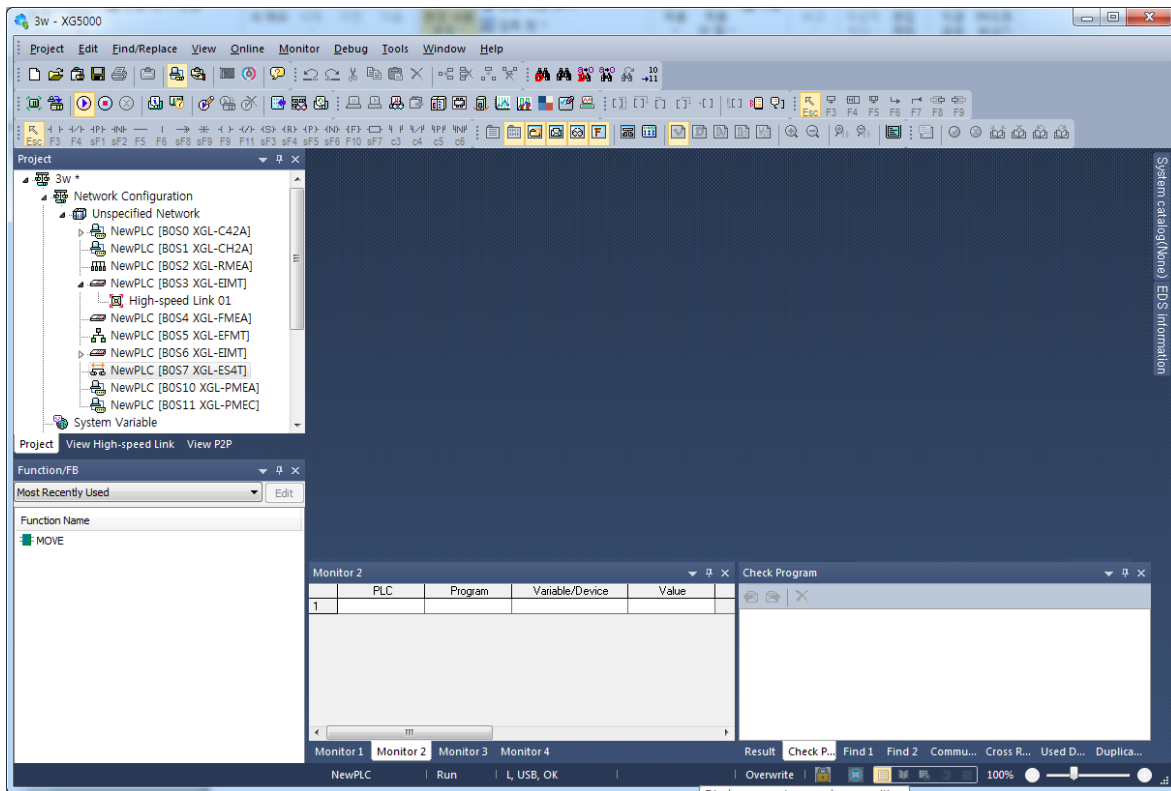

[Fig. 5.5.1] XG5000 basic window

5.5.2 When operating in high speed link service

(1) Parameter setting

Following window will appear when the high speed link parameter is selected.

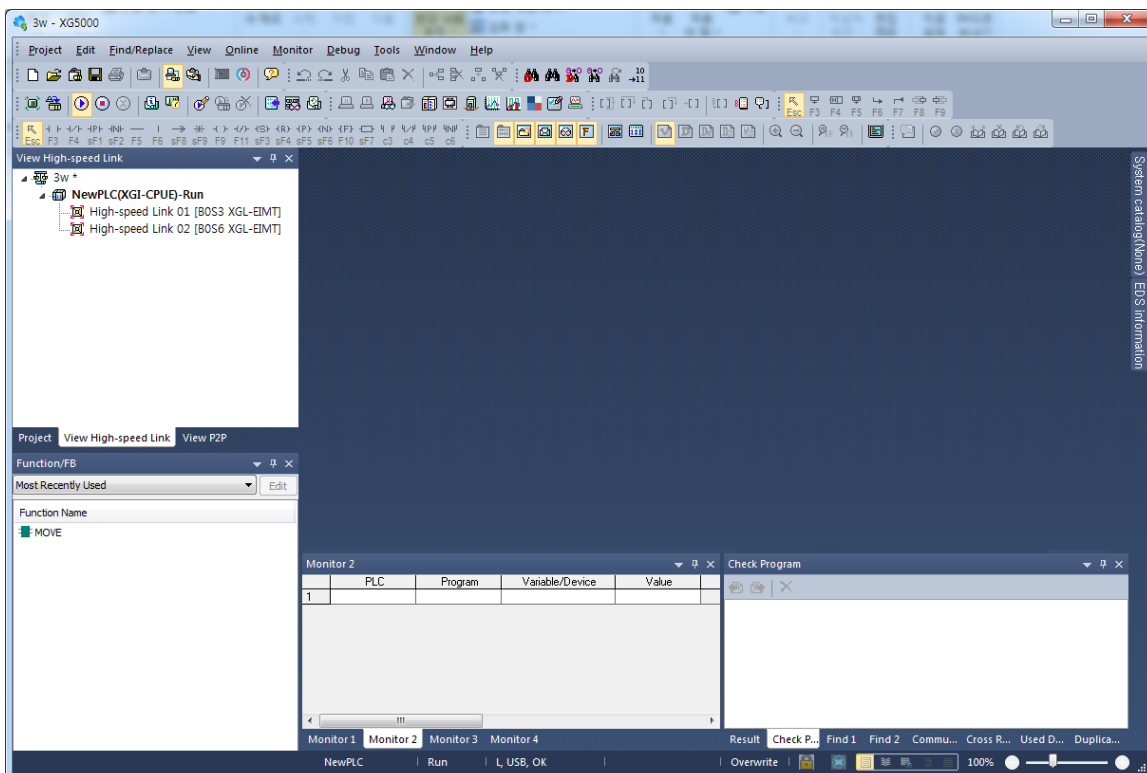

Chapter 5. Communication Parameters

(a) Communication module setting (Select PLC → Right-click → Add Item → Communication Module)

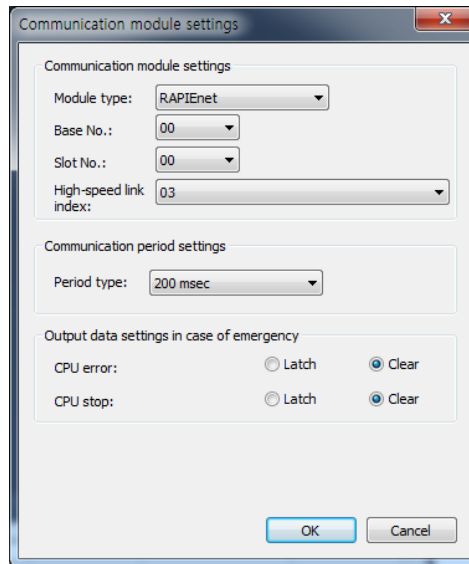

Classification		Description
Communication module settings	Module type	Select PLC2PLC.
	Base Number	Select the No. of the base of the installation.
	Slot number	Select the No. of the slot of the installation.
Communication period settings	Period type	Set the data transmission period.
Output data setup in case of emergency	CPU error	Set the output data at CPU error.
	CPU stop	Set the output data at CPU stop.

When the communication module has been setup, following window will appear.

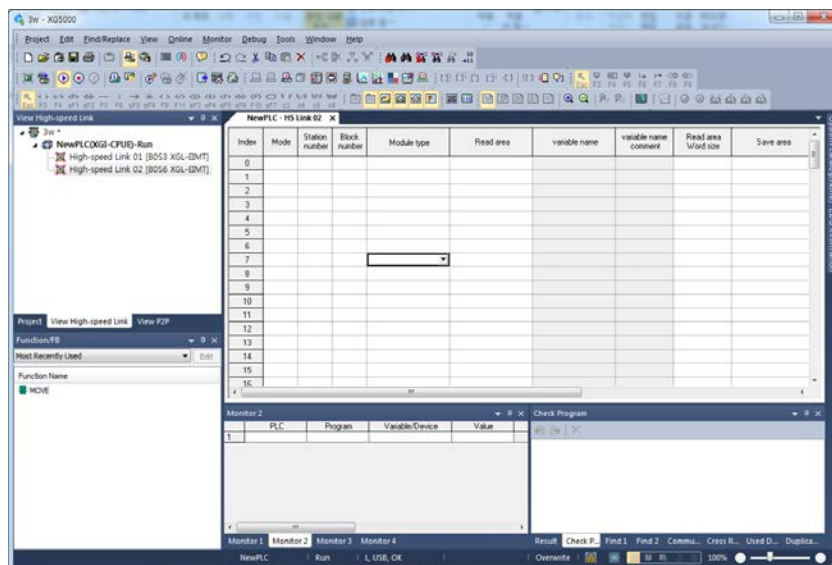

(2) Window for setting high speed link parameters

Index	Mode	Station number	Block number	Read area	Read area Word size	Save area	Save area Word size
0							
1							
2							
3							
4							
5							
6							
7							
8							
9							
10							
11							
12							

The meanings of the parameters are as follow

Classification		Description
Mode	Send	Transmit data
	Receive	Receive data
Station number	Partner station number	The No. of the partner module for the reception
Block number	Block number	Set the No. of the transmission and reception blocks
Read area	Address	Memory area of the module to be transmitted.
Read area Word size	Size (Word)	Set the size of data for transmission.
Save area	Address	The area in the correspondent station where the received data will be stored.
Save area Word size	Size (Word)	Set the size of data for reception

(3) Write high speed link parameters (XG5000 Online → Write)

In the 'Write Parameter' window, select the pertinent high speed link and click Confirm button.

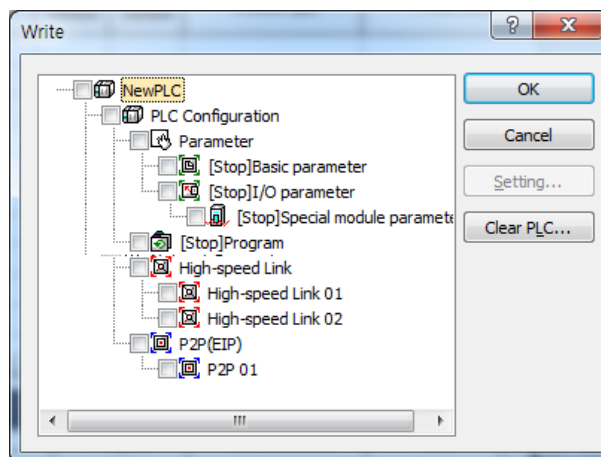

Chapter 5. Communication Parameters

(4) Read high speed link parameter

First, connect with the CPU.

After the connection, select 'Read Parameter' in the online. The window shown in [Fig. 5.5.2] will appear. Select desired parameter and click Confirm button to read the high speed link parameter setting.

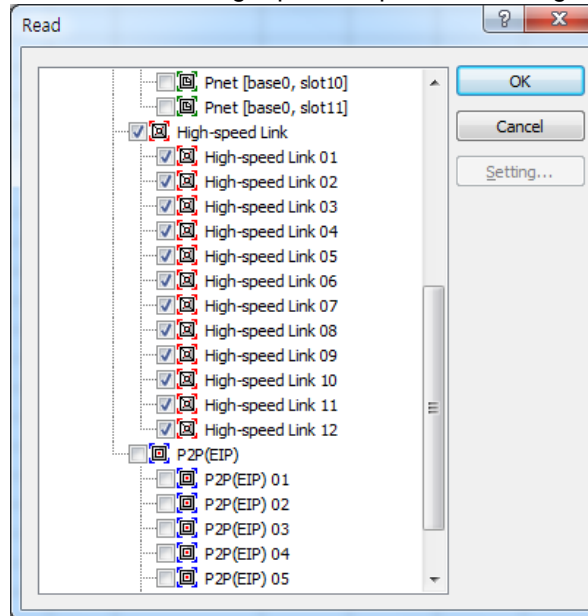

[Fig. 5.5.2] Read Parameter window

(5) Link Enable

- Select 'Online → Communication module setting → Enable Link' or click () icon.
- Select the set up high speed link and click Write.

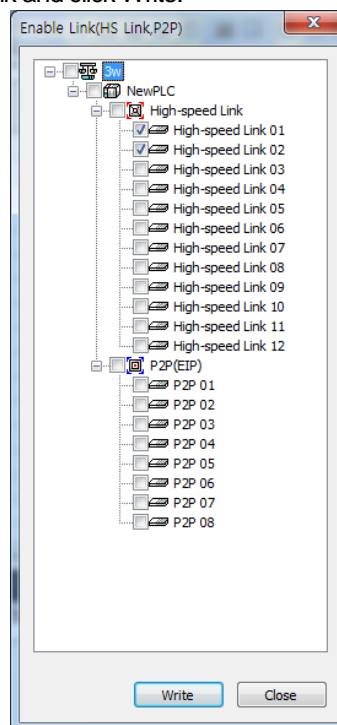

(6) Operation check

- Select 'Online → Communication module setting → System Diagnosis' or click () icon.
- Click the pertinent module. Right-click the mouse and select frame monitoring or service status to check that the communication is normal or not..

* Enable Link through flag

It describes "Enable Link" method through flag. The following XG5000 version, CPU OS version is needed.

Item	Version
XG5000	V3.61 or above
XGR CPU	V1.91 or above
XGI CPU	V3.4 or above
XGK CPU	V3.7 or above

Flag list related with "Enable Link"

-XGR

Flag	Data type	Device	Description
_HS_ENABLE_STATE	ARRAY[0..11] OF BOOL	%FX19040	HS link enable/disable current state
_HS_REQ	ARRAY[0..11] OF BOOL	%FX31520	HS link enable/disable request
_HS_REQ_NUM	ARRAY[0..11] OF BOOL	%FX31536	HS link enable/disable setting
_P2P_ENABLE_STATE	ARRAY[0..7] OF BOOL	%FX19072	P2P enable/disable current state
_P2P_REQ	ARRAY[0..7] OF BOOL	%FX31552	P2P enable/disable request
_P2P_REQ_NUM	ARRAY[0..7] OF BOOL	%FX31568	P2P enable/disable setting

-XGI

Flag	Data type	Device	Description
_HS_ENABLE_STATE	ARRAY[0..11] OF BOOL	%FX15840	HS link enable/disable current state
_HS_REQ	ARRAY[0..11] OF BOOL	%FX16480	HS link enable/disable request
_HS_REQ_NUM	ARRAY[0..11] OF BOOL	%FX16496	HS link enable/disable setting
_P2P_ENABLE_STATE	ARRAY[0..7] OF BOOL	%FX15872	P2P enable/disable current state
_P2P_REQ	ARRAY[0..7] OF BOOL	%FX16512	P2P enable/disable request
_P2P_REQ_NUM	ARRAY[0..7] OF BOOL	%FX16528	P2P enable/disable setting

-XGK

Flag	Data type	Device	Description
_HS1_ENABLE_STATE	BIT	F09600	HS link 1 enable/disable current state
_HS2_ENABLE_STATE	BIT	F09601	HS link 2 enable/disable current state
_HS3_ENABLE_STATE	BIT	F09602	HS link 3 enable/disable current state
_HS4_ENABLE_STATE	BIT	F09603	HS link 4 enable/disable current state
_HS5_ENABLE_STATE	BIT	F09604	HS link 5 enable/disable current state
_HS6_ENABLE_STATE	BIT	F09605	HS link 6 enable/disable current state
_HS7_ENABLE_STATE	BIT	F09606	HS link 7 enable/disable current state
_HS8_ENABLE_STATE	BIT	F09607	HS link 8 enable/disable current state
_HS9_ENABLE_STATE	BIT	F09608	HS link 9 enable/disable current state
_HS10_ENABLE_STATE	BIT	F09609	HS link 10 enable/disable current state
_HS11_ENABLE_STATE	BIT	F0960A	HS link 11 enable/disable current state
_HS12_ENABLE_STATE	BIT	F0960B	HS link 12 enable/disable current state
_HS1_REQ	BIT	F10300	HS link 1 enable/disable request
_HS2_REQ	BIT	F10301	HS link 2 enable/disable request
_HS3_REQ	BIT	F10302	HS link 3 enable/disable request
_HS4_REQ	BIT	F10303	HS link 4 enable/disable request
_HS5_REQ	BIT	F10304	HS link 5 enable/disable request
_HS6_REQ	BIT	F10305	HS link 6 enable/disable request
_HS7_REQ	BIT	F10306	HS link 7 enable/disable request
_HS8_REQ	BIT	F10307	HS link 8 enable/disable request
_HS9_REQ	BIT	F10308	HS link 9 enable/disable request

Chapter 5. Communication Parameters

Flag	Data type	Device	Description
_HS10_REQ	BIT	F10309	HS link 10 enable/disable request
_HS11_REQ	BIT	F1030A	HS link 11 enable/disable request
_HS12_REQ	BIT	F1030B	HS link 12 enable/disable request
_HS1_REQ_NUM	BIT	F10310	HS link 1 enable/disable setting
_HS2_REQ_NUM	BIT	F10311	HS link 2 enable/disable setting
_HS3_REQ_NUM	BIT	F10312	HS link 3 enable/disable setting
_HS4_REQ_NUM	BIT	F10313	HS link 4 enable/disable setting
_HS5_REQ_NUM	BIT	F10314	HS link 5 enable/disable setting
_HS6_REQ_NUM	BIT	F10315	HS link 6 enable/disable setting
_HS7_REQ_NUM	BIT	F10316	HS link 7 enable/disable setting
_HS8_REQ_NUM	BIT	F10317	HS link 8 enable/disable setting
_HS9_REQ_NUM	BIT	F10318	HS link 9 enable/disable setting
_HS10_REQ_NUM	BIT	F10319	HS link 10 enable/disable setting
_HS11_REQ_NUM	BIT	F1031A	HS link 11 enable/disable setting
_HS12_REQ_NUM	BIT	F1031B	HS link 12 enable/disable setting
_P2P1_ENABLE_STATE	BIT	F09620	P2P1 enable/disable current state
_P2P2_ENABLE_STATE	BIT	F09621	P2P2 enable/disable current state
_P2P3_ENABLE_STATE	BIT	F09622	P2P3 enable/disable current state
_P2P4_ENABLE_STATE	BIT	F09623	P2P4 enable/disable current state
_P2P5_ENABLE_STATE	BIT	F09624	P2P5 enable/disable current state
_P2P6_ENABLE_STATE	BIT	F09625	P2P6 enable/disable current state
_P2P7_ENABLE_STATE	BIT	F09626	P2P7 enable/disable current state
_P2P8_ENABLE_STATE	BIT	F09627	P2P8 enable/disable current state
_P2P1_REQ	BIT	F10320	P2P1 enable/disable request
_P2P2_REQ	BIT	F10321	P2P2 enable/disable request
_P2P3_REQ	BIT	F10322	P2P3 enable/disable request
_P2P4_REQ	BIT	F10323	P2P4 enable/disable request
_P2P5_REQ	BIT	F10324	P2P5 enable/disable request
_P2P6_REQ	BIT	F10325	P2P6 enable/disable request
_P2P7_REQ	BIT	F10326	P2P7 enable/disable request
_P2P8_REQ	BIT	F10327	P2P8 enable/disable request
_P2P1_REQ_NUM	BIT	F10330	P2P1 enable/disable setting
_P2P2_REQ_NUM	BIT	F10331	P2P2 enable/disable setting
_P2P3_REQ_NUM	BIT	F10332	P2P3 enable/disable setting
_P2P4_REQ_NUM	BIT	F10333	P2P4 enable/disable setting
_P2P5_REQ_NUM	BIT	F10334	P2P5 enable/disable setting
_P2P6_REQ_NUM	BIT	F10335	P2P6 enable/disable setting
_P2P7_REQ_NUM	BIT	F10336	P2P7 enable/disable setting
_P2P8_REQ_NUM	BIT	F10337	P2P8 enable/disable setting

- ▶ How to enable link
 - HS link/P2P enable/disable setting flag ON → HS link/P2P enable/disable request flag ON
- ▶ How to disable link
 - HS link/P2P enable/disable setting flag OFF → HS link/P2P enable/disable request flag ON
- ▶ You can monitor the Enable/Disable state of the each link through “enable/disable current states” flag.

5.5.3 Operating in P2P service

(1) Parameter setting

Following window will appear when P2P Parameter is selected.

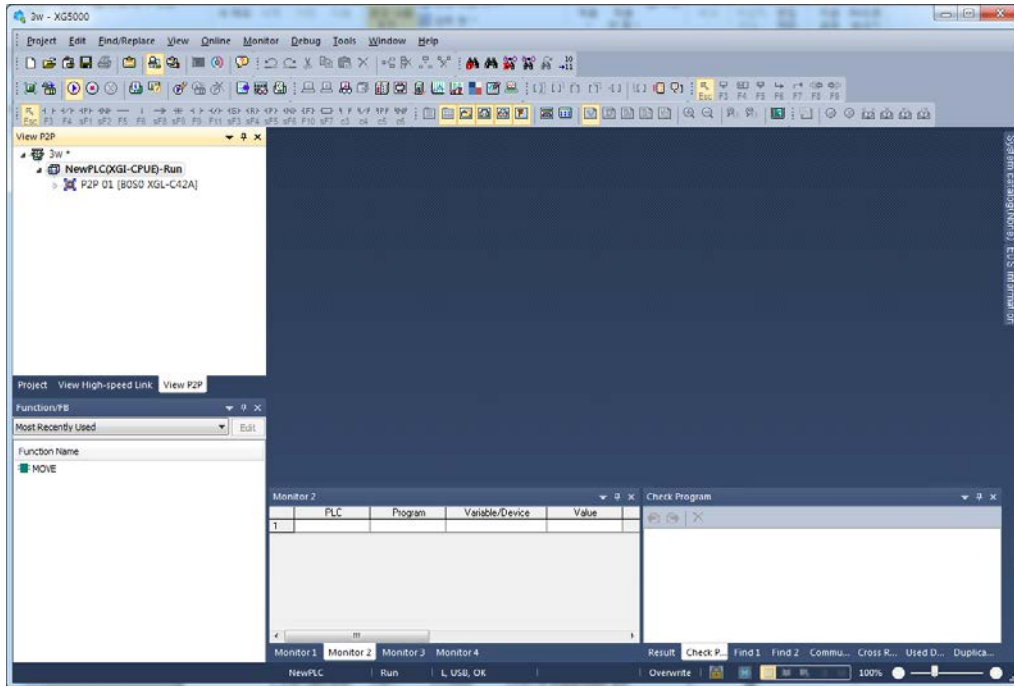

(a) Communication module setting

In the P2P window, right click the PLC → Add Item → P2P Communication to register the module currently in the slot..

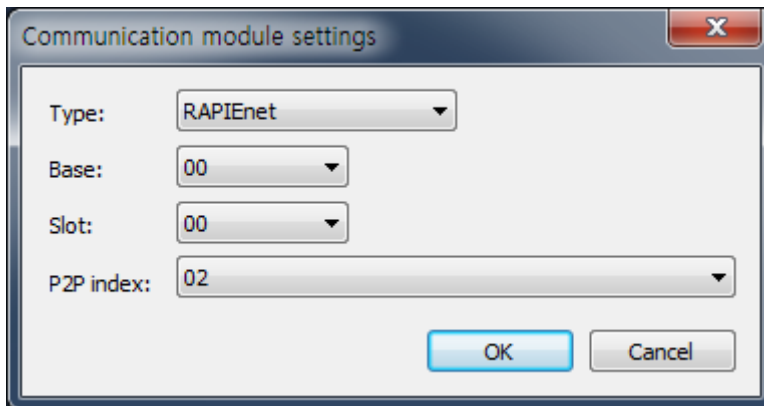

The function of each setting is as follows.

Classification		Description
Communication Module Settings	Type	Select PLC2PLC.
	Base	Select the No. of the base.
	Slot	Select the No. of the slot.

Chapter 5. Communication Parameters

When the communication module has been set up, P2P block will appear in the P2P window. Click this will show following window where P2P blocks can be set up.

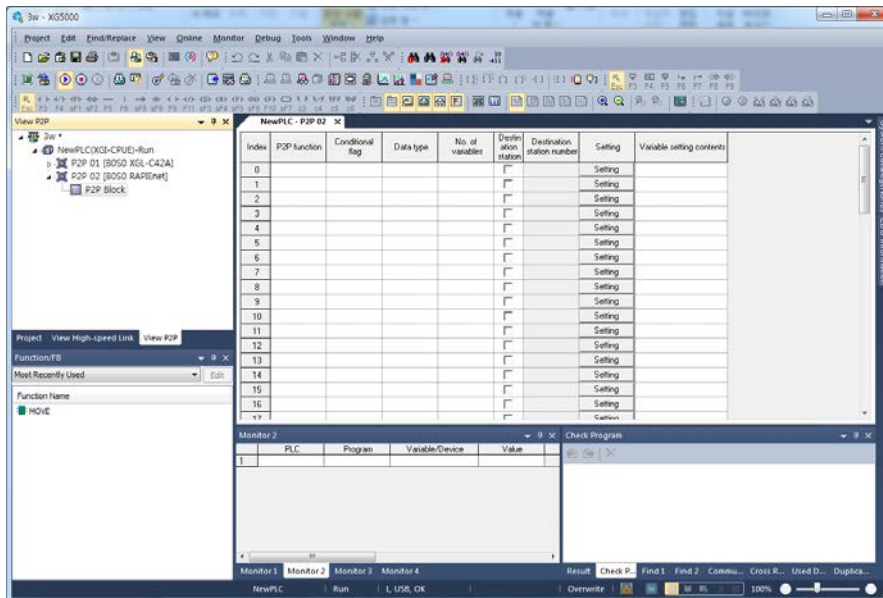

(b) Setting parameter blocks

Classification		Description
P2P Block	P2P function	Select whether to transmit or receive.
	Conditional flag	Set up the conditions of the frame operation.
	Data type	Set up the data unit of the frame.
	No. of variables	Set up the No. of data in the frame.
	Destination station	Set when correspondent station is required.
	Destination station number	Set up the No. of the correspondent station.
Setting	Read area	Set up the XGT device area.
	Save area	
	Data size	Set up the size of the data to be transmitted or received.
	Address	The address of the N device area of the CPU module where the data in the variable setting window will be stored. This address cannot be set up by user.

(c) Write parameters

- 1) Select 'Online → Write' or click () icon.
- 2) In the basic setting, select the Basic Setting and the P2P which has been set up, and click Confirm button
- 3) After clicking the Confirm button and writing parameters, execute individual reset of the pertinent module.

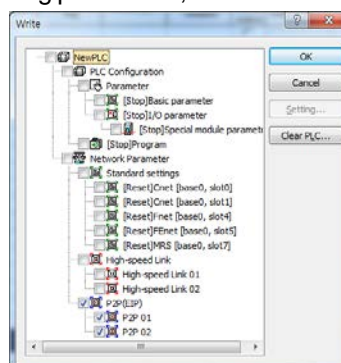

(d) Enable Link e

- 1) Select 'Online → Communication module setting → Enable Link' or click () icon.
- 2) Select the P2P which is set up, and click 'Write.'

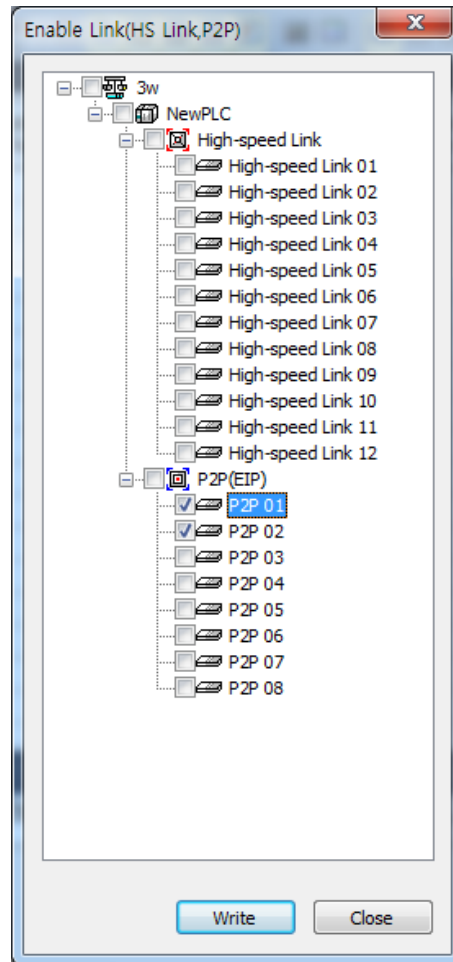

(e) Operation check

- 1) Select 'Online → Communication module setting → System Diagnosis' or click () icon.
- 2) Click the pertinent module. Right-click the mouse and select service status to check that the communication is normal or not..

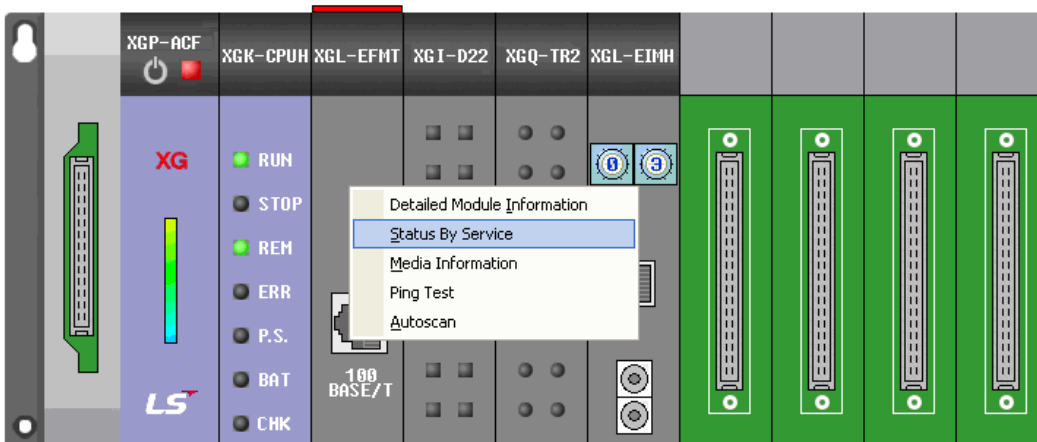

Chapter 6 High-speed Link

6.1 Introduction

High-speed link (HS Link) is a communication method between XGT PLC communication modules to send and receive data with HS link parameters setting, which can also allow the user to use XG5000 to exchange data with parameters setting of Tx/Rx data size, Tx/Rx period, Tx/Rx area and area to save through its data transmission service function.

However, since HS link service uses the subnet broad service, it may have an influence on other communication modules which use the identical network. Thus, setting as near to the max. Tx/Rx size (200 words) as available per HS link block is recommended for the user to obtain the greatest communication efficiency with the lowest influence on other modules so to reduce the sum of blocks.

HS link functions are as specified below;

(1) HS link block setting function

- (a) If there are many Tx/Rx areas, up to 96 blocks can be set (32 for Tx and 64 for Rx respectively).
- (b) 200 words are available for a block.
- (c) Max. link points available are 12,800 words.

(2) Tx/Rx period setting function

Tx/Rx period can be set per block by user for the areas where especially fast Tx/Rx is required and not required respectively in a Tx/Rx period of 20ms to 10 sec.

(3) Tx/Rx area setting function

Tx/Rx area can be set per data block by user according to I/O address specified.

(4) Providing function of HS link information

Reliable communication system can be easily configured by providing HS link information for user via the user keyword.

[Table 6.1.1] shows communication HS link points whose basic unit is 1 word.

Classification	Max. communication points	Max. Tx points	Max. blocks	Max. points per block
XGK CPU	12,800	12,800	128(0-63)	200
XGI CPU	12,800	12,800	128(0-63)	200
XGB CPU	12,800	12,800	64(0-63)	200

[Table 6.1.1] Max. communication points

6.2 HS link Tx/Rx Data Processing

HS link application will be described below with the example where FDEnet I/F modules of the stations No.0 and No.1 are to send and receive the data between each other.

Its setting sequence is as follows;

- (a) The station No.0 transmits M0000 data of 10 words to No.0 block.
- (b) The data received by the station No.1 is saved on M0010.
- (c) The station No.1 receives M0000 data of 10 words from the station No.0 to save on M0100.
- (d) M0110 data of 10 words is transmitted to No.1 block.

There are 64 blocks for Tx data and 128 blocks for Rx data in the HS link parameters. The block number can be set 0~63 for transmission or receiving. The Tx side needs only to decide which data to read and which block to send to without setting the correspondent station No. when transmitting the data

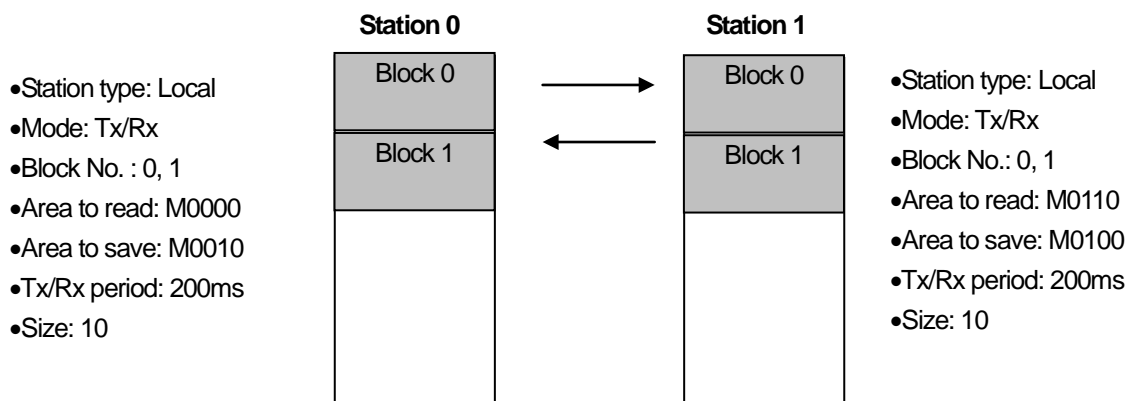

[Table 6.2.1] Diagram of HS link processing blocks

6.3 Operation Sequence through High-speed Link

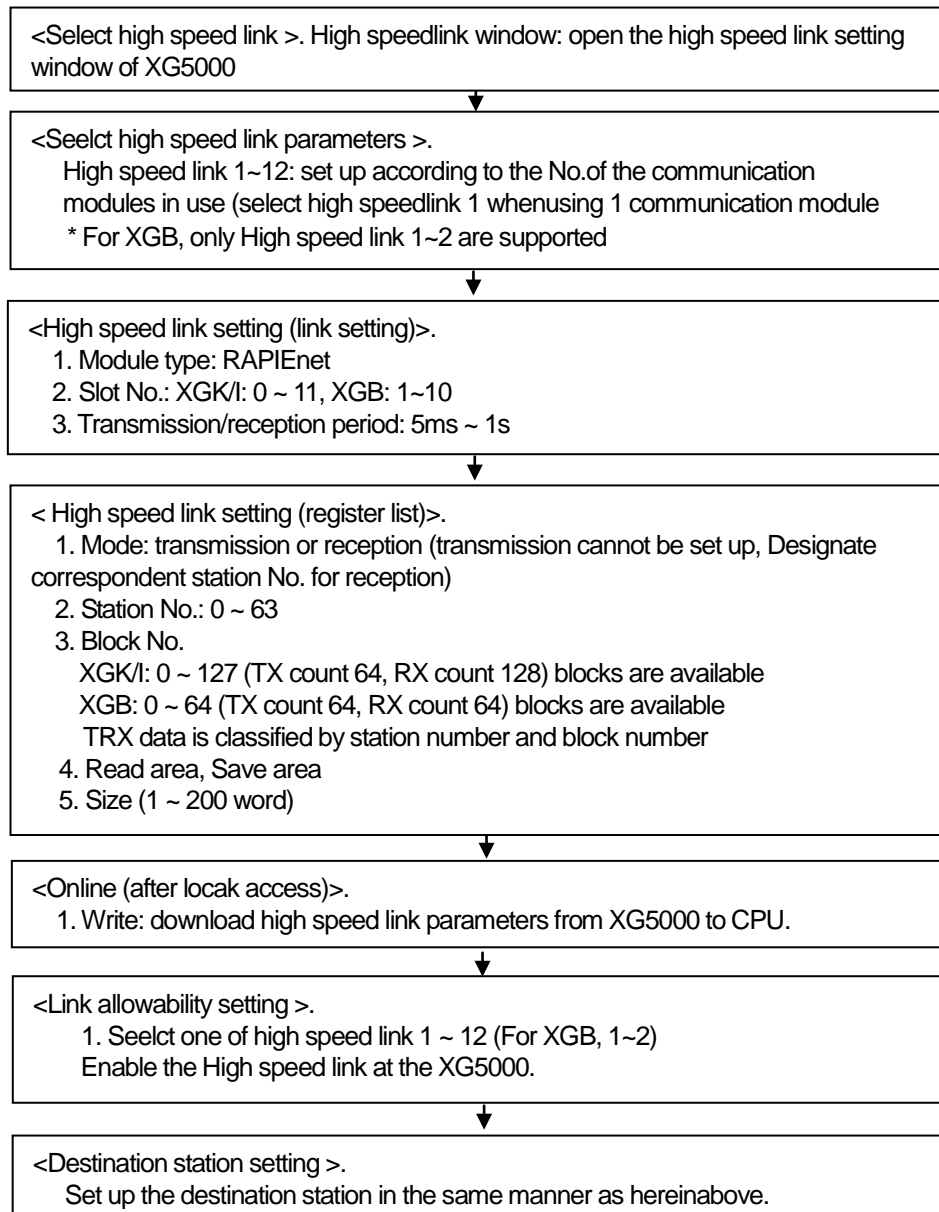

6.4 HS link parameters setting

HS link parameters can be specified as selected on the XG5000's HS link screen for applicable items, whose setting sequence and respective functions are as follows.

6.4.1 HS link parameters setting of XG5000

(1) Execution of XG5000

If XG5000 is executed for the first time, the screen will be displayed as shown in [Fig. 6.4.1].

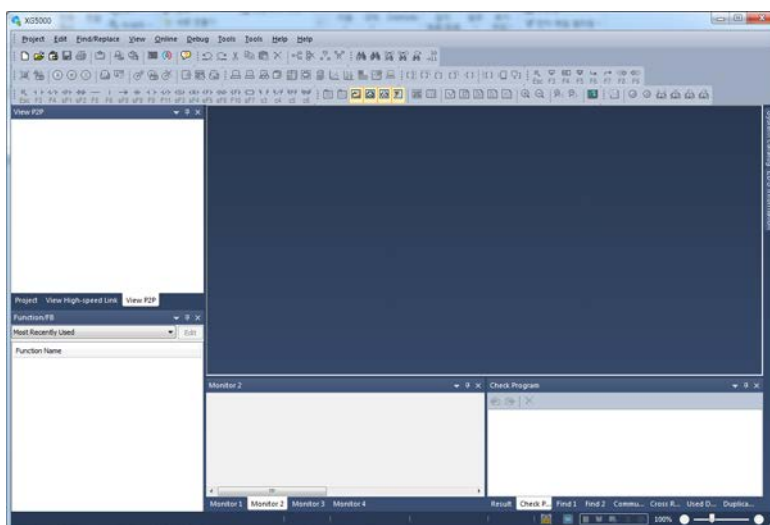

[Fig. 6.4.1] Basic screen of XG5000

(2) Basic setting

In the XG5000 screen, select 'Online' → 'Connect' to access PLC. Select 'Online' → 'Diagnosis' → 'I/O Information' → 'I/O Sync'. The RAPIEnet I/F Module installed on the base appears in the basic setting window as shown in [Fig. 6.4.2].

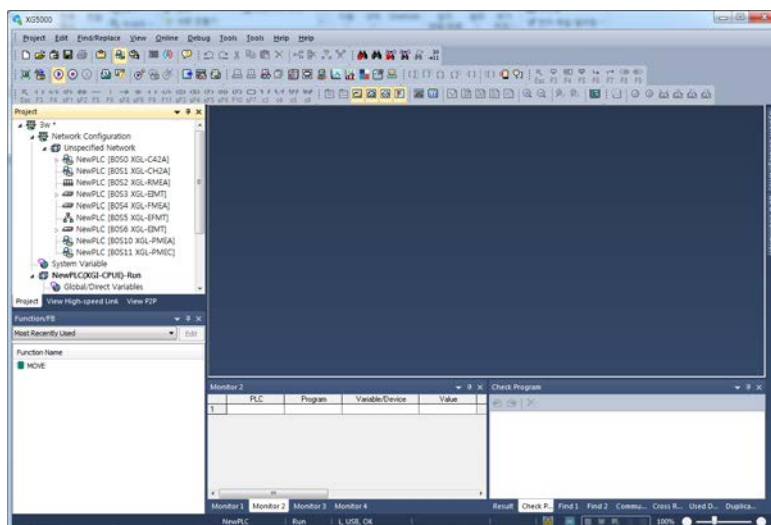

[Fig. 6.4.2] Basic setting screen

(3) High-speed link parameter setting

(a) Initial screen setting of High-speed link parameter

Select XG5000's HS link window as shown on [Fig. 6.4.3].

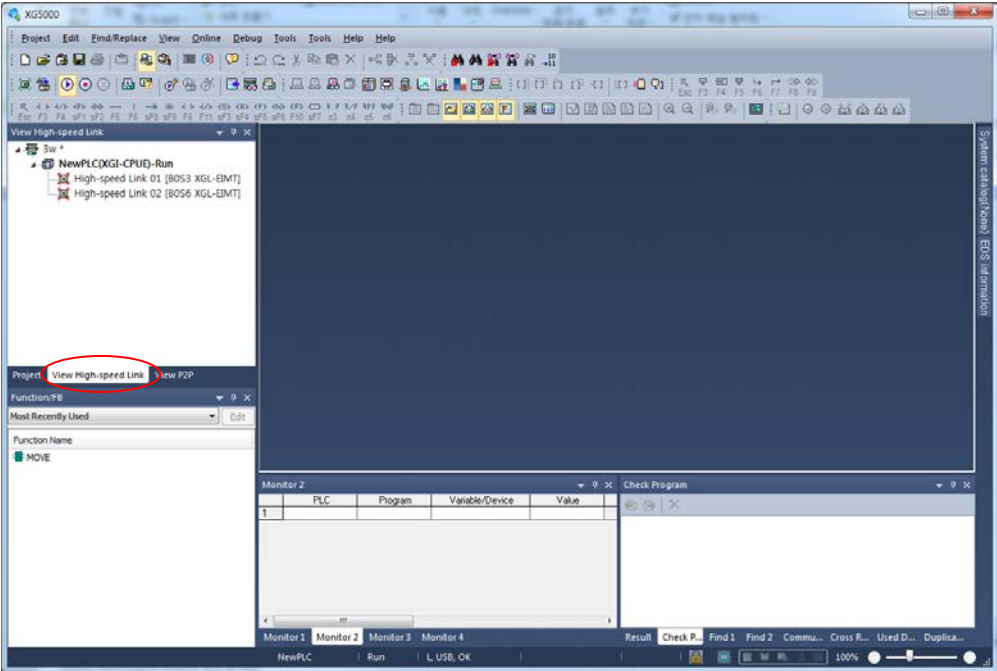

[Fig. 6.4.3] Initial setting screen of High-speed link

(b) Setting of communication module and communication period

Right-click on the PLC and select 'Add Item' → 'High-speed Link Communication' to open the setting screen of communication module and communication period where communication module and communication period can be specified.

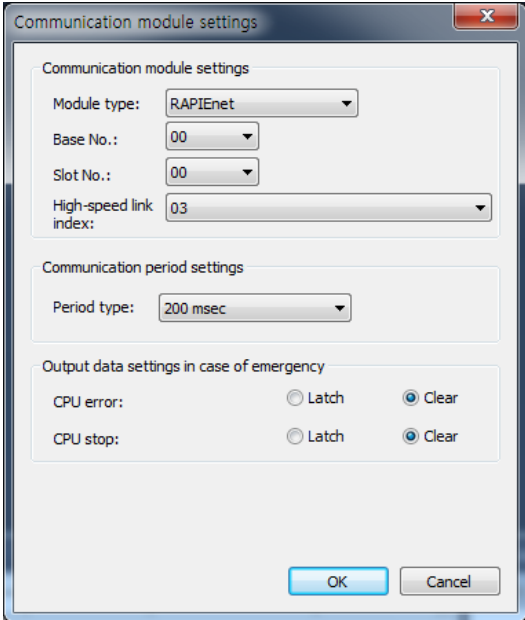

[Fig. 6.4.4] Initial setting screen of High-speed link

Item		Details
Communication module setting	Module type	Specify the communication module installed. (RAPIEnet)
	Base no.	Specify the base position the module is installed on (max. 7 stages can be added). Setting range: 0 ~ 7
	Slot no.	Specify the slot position the module is installed on (max. 12 units can be added). Setting range: 0 ~ 11
Communication Period setting	Period type	<ul style="list-style-type: none"> - Set data Tx at periodic intervals. - Setting range: 5ms, 10ms, 20 ms, 50 ms, 100 ms, 200 ms, 500 ms, 1s (Default period: 5 ms) - However, Rx data will update the data whenever scanned regardless of the communication period. - The communication period will be applied identically to the whole Tx/Rx blocks. - Up to 4 blocks of data can be sent at a time. Even if this is exceeded, the data will be divided into 4-block unit for transmission, with which the data size of a block has noting to do.
Output data settings in case of emergency	CPU Error	Set up the output data at CPU error <ul style="list-style-type: none"> - Latch: latched to the output just before the CPU error. - Clear: cleared to '0'.
	CPU Stop	Set up the output data at CPU stoppage <ul style="list-style-type: none"> - Latch: latched to the output just before the CPU stoppage. - Clear: cleared to '0'.

[Table 6.4.1] Setting of communication module and communication period

(c) High-speed link parameter setting

Click [OK] on [Fig.6.4.4] to display [Fig.6.4.5].

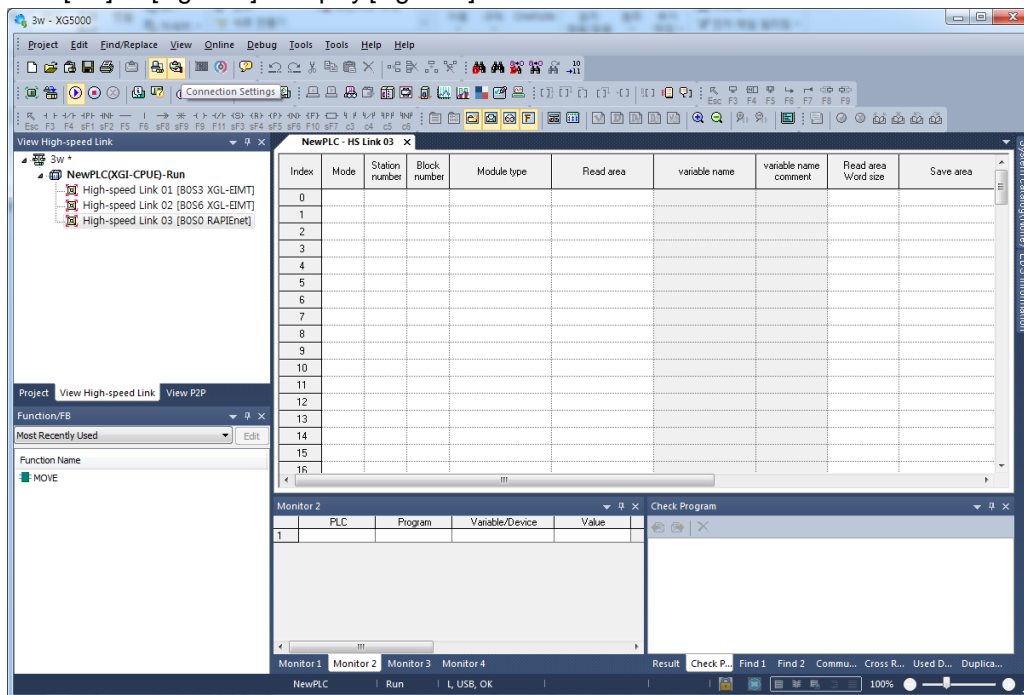

[Fig. 6.4.5] Initial setting screen of HS link

(d) Setting of High-speed link blocks

Double-click High-speed link on [Fig.6.4.5] to open [Fig.6.4.6].

Index	Mode	Station number	Block number	Read area	Read area Word size	Save area	Save area Word size
0							
1							
2							
3							
4							
5							
6							
7							
8							

[Fig. 6.4.6] Setting screen of HS link blocks

Classification		Details
Mode	Send	Send data
	Receive	Receive data
Station number	Partner station number	Settable in case of Receive mode Range: 0 ~ 63
Block number	Block number	Set TRX block TX block: Max. 64 block (setting range: 0 ~ 63) → Duplicated block number is not allowed RX block: Max. 128 block (setting range: 0 ~ 63) → Same station number : Duplicated block number is not allowed → Other station number : Duplicated block number is allowed
Read area	Address	Set device area used when receiving Setting device - XGK: P, M, L, K, D, T, C, U, N, R, ZR - XGI: M, I, Q, R, W It shall not be duplicated with the device address being used in program.
Read area Word size	Size (Word)	Set data size to send Setting unit : Word Setting range :1 ~ 200
Save area	Address	Set device area used when receiving Setting device - XGK: P, M, L, K, D, T, C, U, N, R, ZR - XGI: M, I, Q, R, W It shall not be duplicated with the device address being used in program
Save area Word size	Size (Word)	Set data size to receive. Setting unit : Word Setting range :1 ~ 200

[Table 6.4.2] High-speed link setting

(4) How to download High-speed link parameters

Click “Online” → “Write” in XG5000, check the applicable HS link and then click [OK].

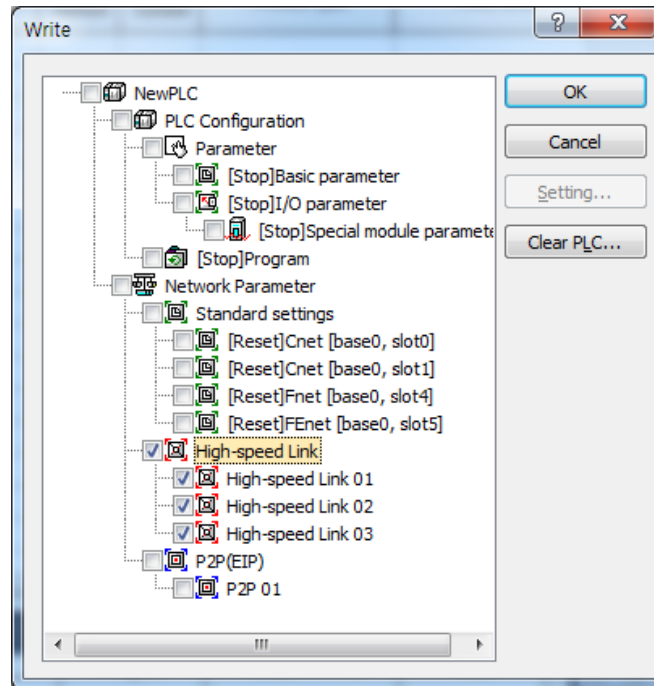

[Fig. 6.4.7] Write Parameter Screen

(5) High-speed link parameter setting

Click “Online” → “Communication module setting” → “Enable Link” in XG5000, check the applicable HS link and then click [Write]. If HS link is enabled, on the module’s LED display HS LED will be On, when HS link starts.

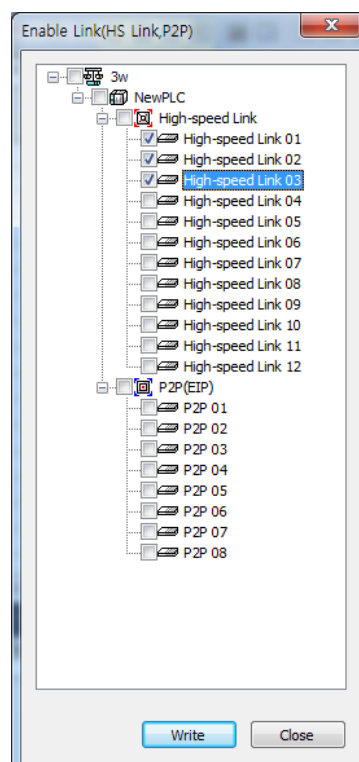

[Fig. 6.4.10] Link Enable Screen

6.5 High-speed link information

6.5.1 High-speed link flag

With HS link service used to exchange data between communication modules of two or more stations, it provides a checking method of HS link service status for the user through HS link information so to confirm reliability of the data read from the correspondent station via the HS link. In other words, the communication module synthesizes the data received up to that time at intervals of a specific time and lets the user know if HS link operates as in parameters specified by the user through HS link information where the whole information of Run-link(_HSxRLINK) and Link-trouble(_HSxLTRBL) to provide the whole information of the communication network, and the individual information of _HSxSTATE, _HSxTRX, _HSxMOD and _HSxERR to provide communication status for 64 register items in the parameters are contained. The user can use the information in keyword format when programming, and also monitor the HS link status using the monitor function of the HS link information. Prior to its application, the user is requested to check the reliability of the Tx/Rx data through HS link information of Run-link and Link-trouble when operating several PLCs with HS link used. [Table 6.5.1] below shows functions and definition of the HS link information.

Classification	Run-link	Link-trouble	Tx/Rx status	Operation Mode	Error	HS link status
Information type	Whole information	Whole information	Individual information	Individual information	Individual information	Individual information
Keyword name (x=HS link No.)	_HSxRLINK	_HSxLTRBL	_HSxTRX[n] (n=0..127)	_HSxMOD[n] (n=0..127)	_HSxERR[n](n=0..127)	_HSxSTATE[n](n=0..127)
Data type	Bit	Bit	Bit-Array	Bit-Array	Bit-Array	Bit-Array
Monitor	Available	Available	Available	Available	Available	Available
Program	Available	Available	Available	Available	Available	Available

[Table 6.5.1] HS link information function

Double-click [Variable/Comment] (XGK) or [Global/Direct Variables] (XGI/R) on the XG5000 project screen to display the flags view screen as shown below on [Fig. 6.5.1]. From this screen drag the applicable device on to the variable monitor window.

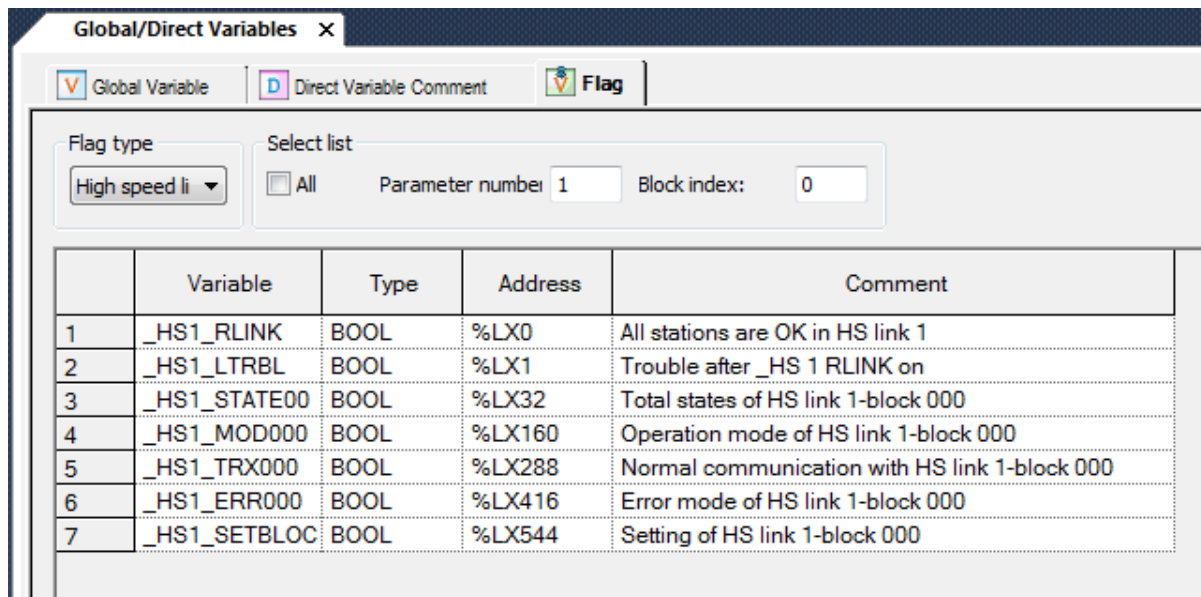

[Fig. 6.5.1] High-speed link Flag

(1) Run-link (_HSxRLINK, x=HS link no. (1~12))

As the whole information it shows whether HS link is normally executed through the user defined parameters, whose contact will be kept 'On' if once 'On' until Link Enable is 'Off', and also will be 'On' under the conditions specified below.

- ① If Link Enable is 'On'.
- ② If all the register list settings of parameters are specified normally.
- ③ If all the data applicable to the parameters register list is transmitted and received as specified in the period.
- ④ If the status of all the correspondent stations specified in the parameters is Run and with no error at the same time.

(2) Link-trouble (_HSxLTRBL x=HS link no. (1~12))

As the whole information it shows whether HS link is normally executed through the user defined parameters, which will be 'On' if Run-link 'On' condition is violated when Run-link is On, and will be off if the condition is recovered.

(3) Tx/Rx status (_HSxTRX[0..127], x= HS link no. (1~12))

As individual information it shows the operation status of HS link parameters on the register list up to 127 registered items Tx/Rx information. If the Tx/Rx operation of the registered items is agreeable to the Tx/Rx period, the applicable bit will be On, and if not, it will be Off.

(4) Operation mode (_HSxMODE[0..127], x= HS link no. (1~12))

As individual information it shows the operation status of HS link parameters on the register list up to 127 registered items' operation mode information just like the max. register number. If the station specified in the register item is in Run mode, the applicable bit will be On, and if in Stop/Pause/Debug mode, it will be Off.

(5) Error (_HSxERR[0..127] x=HS link no. (1~12))

As individual information it shows the operation status of HS link parameters on the register list up to 127 registered items' error information just like the max. register number. The error displays the general status of the PLC which fails to execute the user program. If the correspondent station PLC is normal, it will be Off, and if abnormal, it will be On.

(6) HS link status (_HSxSTATE[0..127], x= HS link no. (1~12))

As individual information it shows the operation status of HS link parameters on the register list up to 127 registered items' HS link status just like the max. register number, which synthesizes the information of the individual items to display the general information of the registered items. In other words, if the applicable list's Tx/Rx status is normal with the operation mode of Run and with no error, it will be On, and if the conditions above are violated, it will be Off.

6.5.2 Monitor of High-speed link information

HS link information can be checked through the variable monitor on the monitor menu after XG5000 is on-line connected, or through the XG5000 diagnosis service.

(1) Variable Monitor

Variable monitor is a function used to select an item only necessary to monitor by means of XG5000's flag monitor function. Select [View] [Variable Monitor Window] to display the variable register screen as shown on [Fig. 6.5.1], and there select [Flag] directly to select and register HS link information flag one by one on the screen of the variable flags list. At this time, since _HSxSTATE[n], _HSxERR[n], _HSxMOD[n] and _HSxTRX[n] are the flags of array type, the user needs directly to select the array numbers which stand for the register numbers inside the parameters.

(2) High-speed link monitor from the XG5000 diagnosis services

(a) Select XG5000 → 'Connect' → 'Online' → 'Communication module setting' → 'System Diagnosis,' place the mouse pointer on the XGL-EIMT. Right-click the mouse button, select "Status by service' and select the High Speed Link Service tab. A screen shown in [Fig. 6.5.2] will appear.

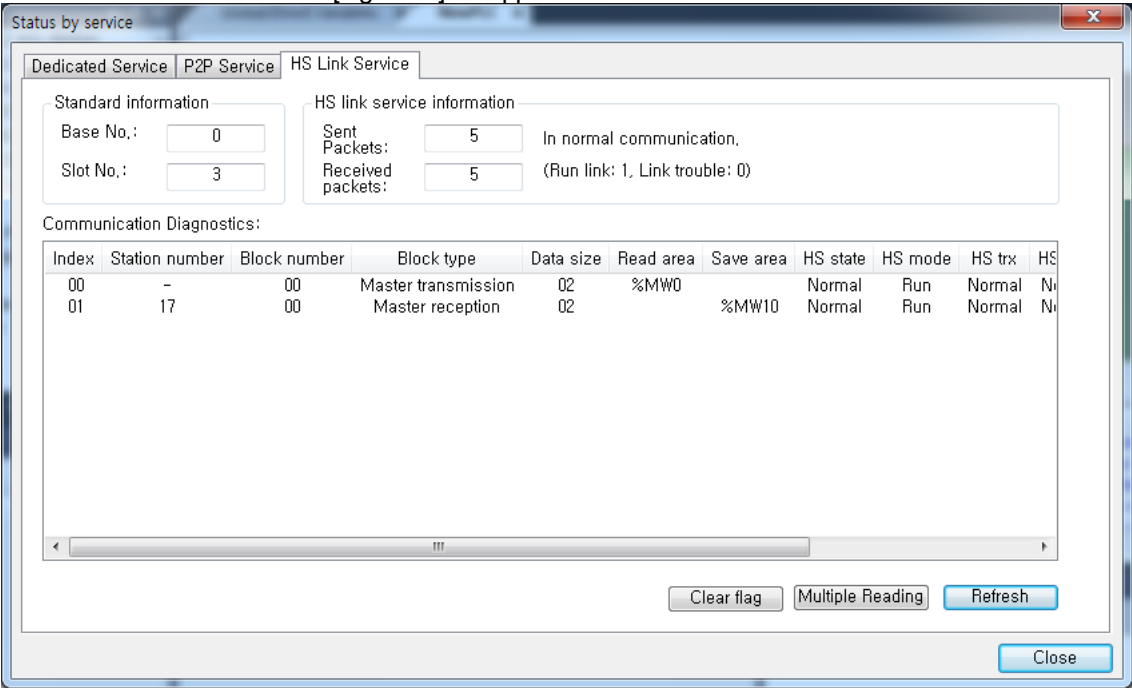

[Fig. 6.5.2] Service statuses; high speed link service screen

- (b) To monitor the high speed link of another PLC2PLC module on the network, select XG5000 → 'Connect' → 'Online' → 'Communication module setting' → 'System Diagnosis,' place the mouse pointer on the XGL-EIMT. Right-click the mouse button, select 'Autoscan.' A screen shown in [Fig. 6.5.3] will appear.

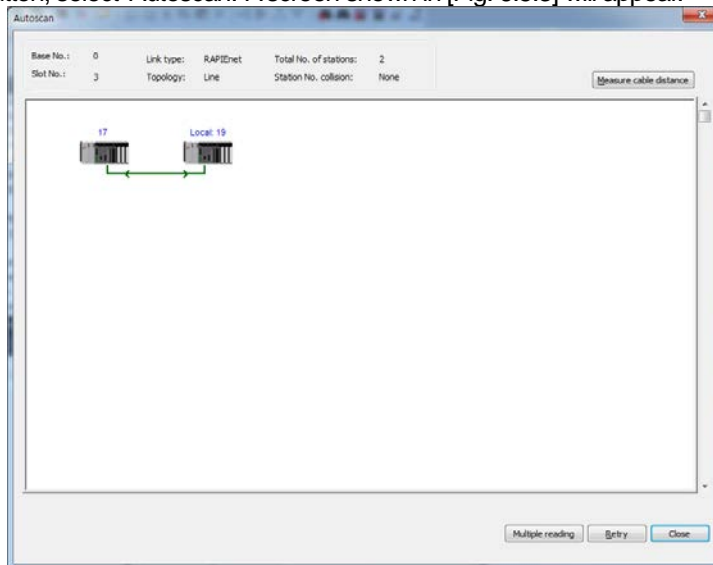

[Fig. 6.5.3] Autoscan screen

In the Autoscan window shown in [Fig. 6.5.3], place the mouse pointer on the RAPIEnet I/F Module for which the high speed link service is to be monitored. Right-click the mouse button and select 'Status by service.' The high speed link statuses of other RAPIEnet I/F Modules on the network can be monitored, as shown in [Fig. 6.5.4].

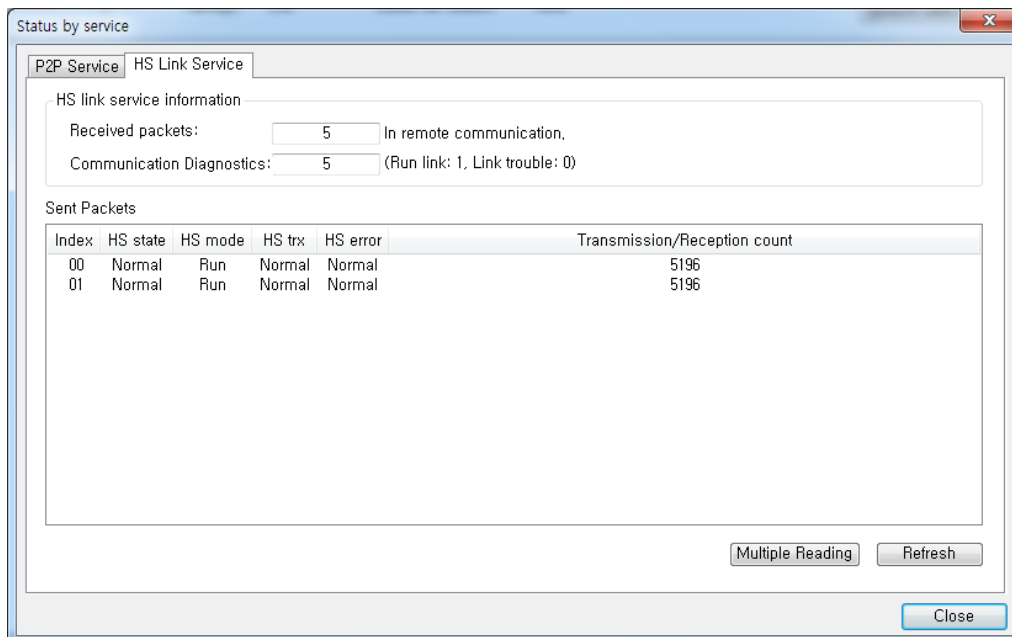

[Fig. 6.5.4] High speed link remote monitoring screen

Chapter 7 P2P Service

7.1 Introduction

This service is used to write the self-station's data on a specific area of the correspondent station, or to read the data from a area of the correspondent station.

Type and application of P2P provided for users will be described.

Programming sequence with P2P used is as follows;

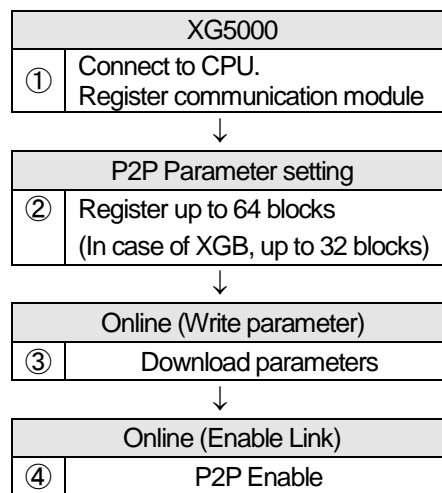

7.2 P2P Instruction

(1) P2P Instruction

There are two P2P Instructions used for user to prepare programs.

Type	Purpose
Read	Reads the specified area of the correspondent station to save.
Write	Saves the specified area data of the self-station on the specified area of the correspondent station.

[Table 7.2.1] P2P type

7.3 P2P Application

In order to execute P2P service, register communication modules on the XG5000's P2P register window, where up to 64 P2P blocks can be set.

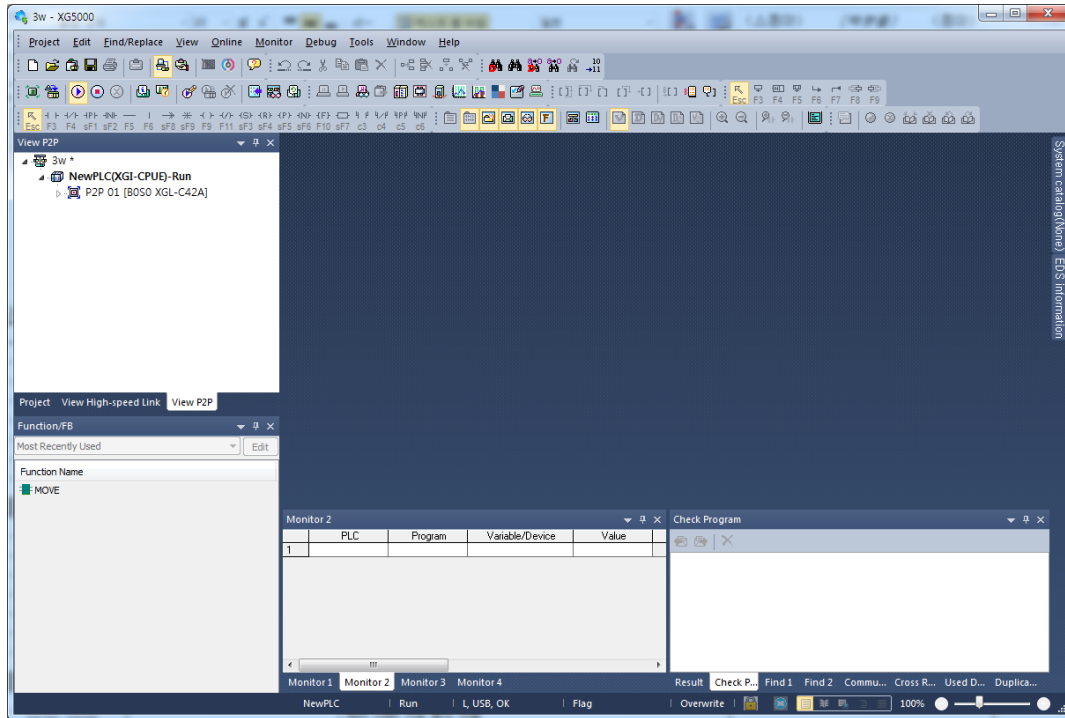

[Fig. 7.3.1] P2P parameters screen

First, register the communication modules to execute P2P service so to set P2P blocks on the empty P2P register window as above.

In order to define P2P service for PLC2PLC installed on Base 0, Slot 3 to execute, select one among P2P 1~8 first.

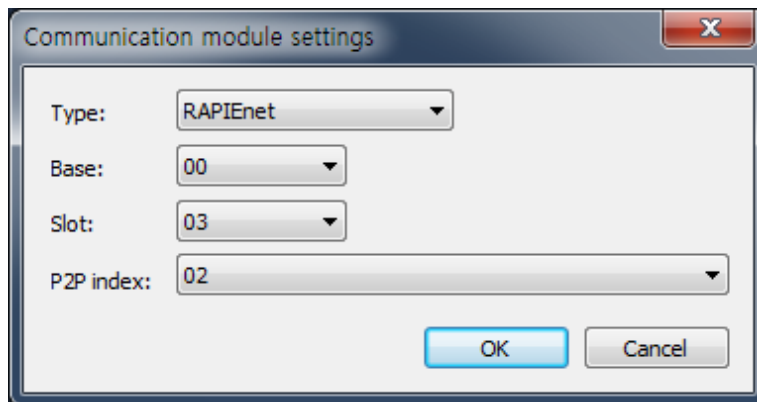

[Fig. 7.3.2] Setting screen of communication module

Item	Details
Type	Select a module desired to use.
Base	Select a base where PLC2PLC module is installed.
Slot	Select a slot where PLC2PLC module is installed.

Register type, base and slot positions in [Fig. 7.3.2] and click [OK] to display the screen as shown in [Fig. 7.3.3].

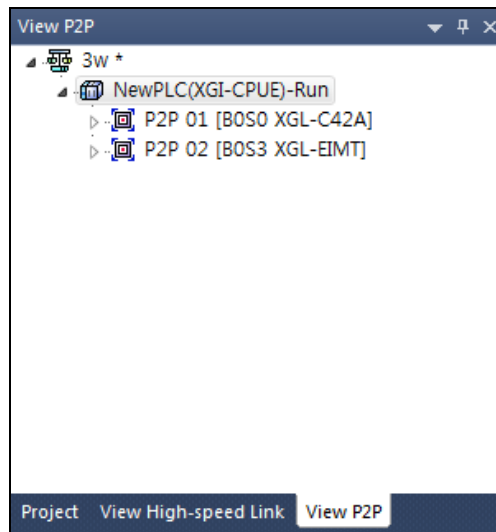

[Fig. 7.3.3] P2P parameters screen

Double-click P2P block in [Fig. 7.3.3] to display the 'P2P block setting' screen as shown in [Fig. 7.3.4].

Index	P2P function	Conditional flag	Data type	No. of variables	Destination station	Destination station number	Setting	Variable setting contents
0					<input type="checkbox"/>		Setting	
1					<input type="checkbox"/>		Setting	
2					<input type="checkbox"/>		Setting	
3					<input type="checkbox"/>		Setting	
4					<input type="checkbox"/>		Setting	
5					<input type="checkbox"/>		Setting	
6					<input type="checkbox"/>		Setting	
7					<input type="checkbox"/>		Setting	
8					<input type="checkbox"/>		Setting	

[Fig. 7.3.4] P2P block setting

Item	Description
Index	The P2P setting blocks. Setup from '0' to '63'.
P2P function	Instruction (Write/Read) is set up.
Conditional flag	Condition for executing instruction is set up.
Data type	Data unit of the frame is set up.
No. of variables	The number of data in frame can be set up. Up to 4 is available.
Destination station	Check when destination station is needed
Destination station number	Set the Destination station number for communication
Setting	Set the read area, save area and data size
Variable setting contents	Display the contents that set in the setting

7.3.1. Functions and setting of P2P

On the [Fig. 7.3.4] P2P block setting screen, double-click the P2P function screen as shown below in [Fig. 7.3.5].

Index	P2P function	Conditional flag	Data type	No. of variables	Destination station	Destination station number	Setting	Variable setting contents
0	▼				<input type="checkbox"/>		Setting	
1	READ				<input type="checkbox"/>		Setting	
2	WRITE				<input type="checkbox"/>		Setting	
3					<input type="checkbox"/>		Setting	

[Fig. 7.3.5] P2P function screen

(1) READ

It is used to read the specified area of the correspondent station to save on the specified area of the self-station when the defined event happens. If IX0.0.0 is set, data of correspondent station No.29's MW100 and MW110 will be read word by word to be saved on RW20 and RW21 of the self-station with the following setting;

- P2P block setting is set as shown below [Fig. 7.3.6].

Index	P2P function	Conditional flag	Data type	No. of variables	Destination station	Destination station number	Setting	Variable setting contents
0	READ	%IX0.0.0	WORD	2	<input checked="" type="checkbox"/>	29	Setting	Number :2READ1:%MW0,SAV
1					<input type="checkbox"/>		Setting	
2					<input type="checkbox"/>		Setting	
3					<input type="checkbox"/>		Setting	

[Fig. 7.3.6] P2P block setting screen

Meaning of each item is as follows.

Item	Details
P2P function	Select P2P function (READ).
Conditional flag	1) Define the time of the READ function is started. 2) If set to %IX0.0.0, the function starts when IX0.0.0 is set.
Data type	1) In the READ function, define the data type of the area used in the P2P block. 2) LWord, DWord, Word, Byte and Bit can be selected.
No. of variables	1) Define the No. of the areas where READ function will be executed per index. 2) If set by 2, 2 write/read areas can be set up.
Destination station	1) Determine whether correspondent station will be designated or not. 2) When selected, the No. of the correspondent station can be designated. If not selected, correspondent station can be changed on the software program.
Destination station number	No. of the correspondent station to read from.
Setting	If selected, the areas and data sizes of variables can be set up.

- Variable setting: if you click Setting in the P2P block setting window. The Variable Setting window will appear, as shown in [Fig. 7.3.7].

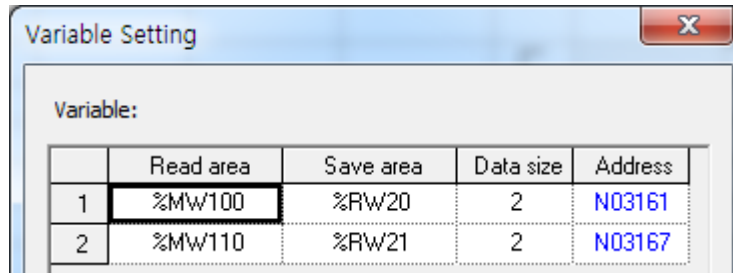

[Figure 7.3.7] Variable setting window

(2) WRITE

It is used to write the data of the self-station on an optional area of the correspondent station when the defined event happens. If Bit FX147 is set, 5 words from MW120 of the self-station will be saved on MW200 of the correspondent station No.5 with the following setting.

- P2P block setting: set up as [Figure 7.3.8]

Index	P2P function	Conditional flag	Data type	No. of variables	Destination station	Destination station number	Setting	Variable se
0	WRITE	%FX147	WORD	1	<input checked="" type="checkbox"/>	5	Setting	Number :1READ1-%MW120.SAVE
1					<input type="checkbox"/>		Setting	
2					<input type="checkbox"/>		Setting	
3					<input type="checkbox"/>		Setting	

[Figure 7.3.8] P2P block setting screen

Meaning of each item is as follows.

Item	Details
P2P function	Select P2P function (Write).
Conditional flag	1) Define the time of the READ function is started. 2) If set to %FX147, the function starts when %FX147 is set.
Data type	1) In the WRITE function, define the data type of the area used in the P2P block. 2) LWord, DWord, Word, Byte and Bit can be selected.
No. of variables	1) Define the No. of the areas where WRITE function will be executed per index. 2) If set by 2, 2 write/read areas can be set up.
Destination station	1) Determine whether correspondent station will be designated or not. 2) When selected, the No. of the correspondent station can be designated. If not selected, correspondent station can be changed on the software program.
Destination station number	No. of the correspondent station to write to.
Setting	If selected, the areas and data sizes of variables can be set up.

- Variable setting: if you click Setting in the P2P block setting window. The Variable Setting window will appear, as shown in [Fig. 7.3.9].

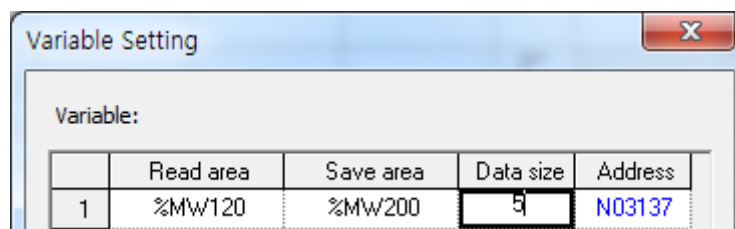

[Figure 7.3.9] Variable setting window

7.4 Operation Sequence of P2P Service

After P2P setting is complete, download the P2P parameters and start the P2P service to make the service available.

(1) P2P parameters download

In order to download the P2P parameters after registered, first connect XG5000 to CPU.

Select [Online] - [Write] to arrange and display the P2P parameters registered among P2P parameters 0~7 as shown below;

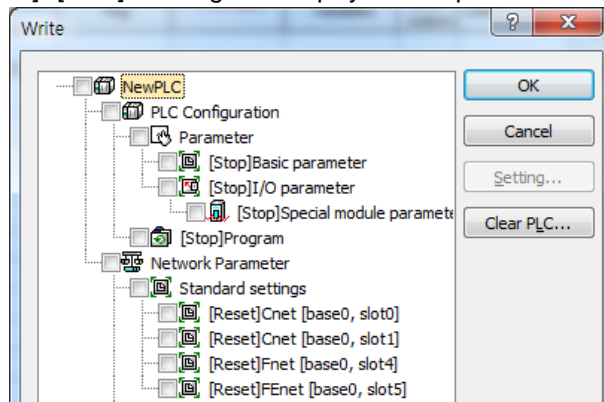

[Fig. 7.4.1] Parameters setting screen

Select desired P2P parameters and click [OK] to start to download.

(2) P2P service start

P2P parameters after downloaded shall be enabled by user to start P2P service. Select “Online – Communication module setting - Enable Link” to display the screen as shown below;

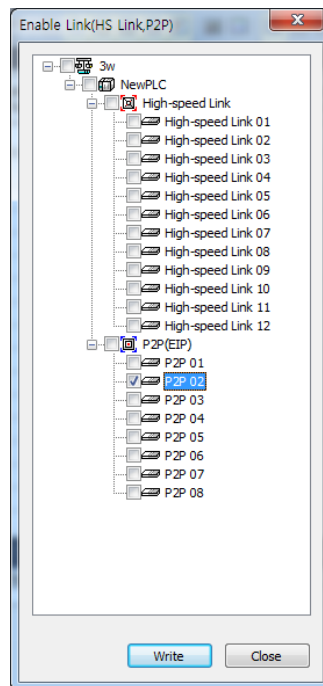

[Fig. 7.4.3] Parameters setting screen

Among P2P parameters 0~7, presently operation P2P parameters are checked, among which check P2P parameters to be enabled and click [OK] to execute the service for the applicable P2P parameters.

In order to stop P2P service, cancel the check mark of the applicable P2P parameters on the link enable screen and then click [OK].

7.5 P2P Service Information

P2P service information provides P2P related data through XG5000.

7.5.1 P2P service from the XG5000 system diagnosis

(a) Select XG5000 → 'Connect' → 'Online' → 'Communication module setting' → 'System Diagnosis'.

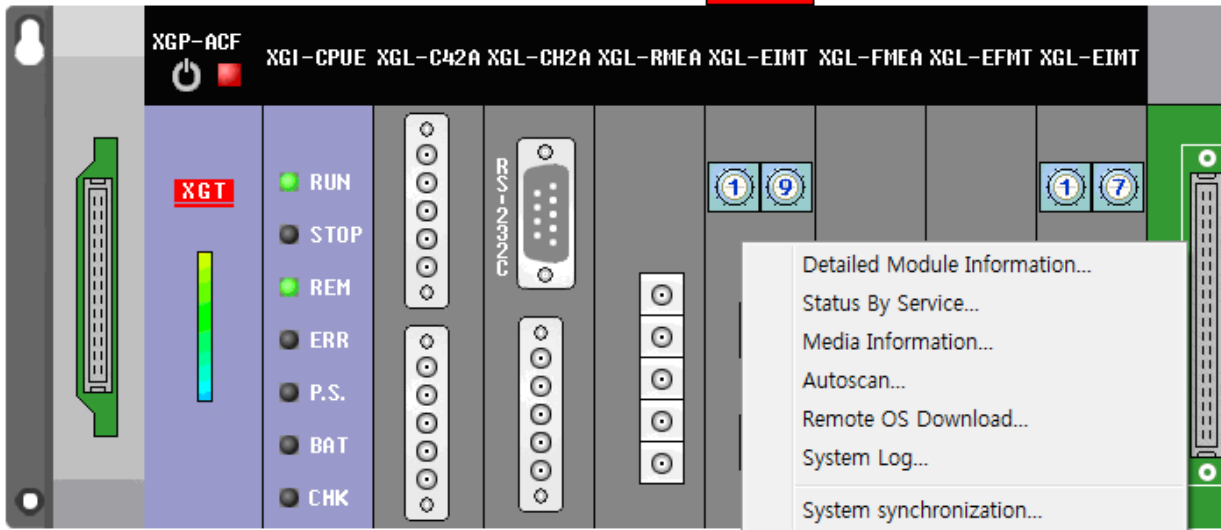

[Fig. 7.5.1] System Diagnosis

(b) With the mouse cursor placed on XGL-EIMH, click the right mouse button and select 'Status by service' to open [Fig. 7.5.2] as shown below, where P2P service information can be checked.

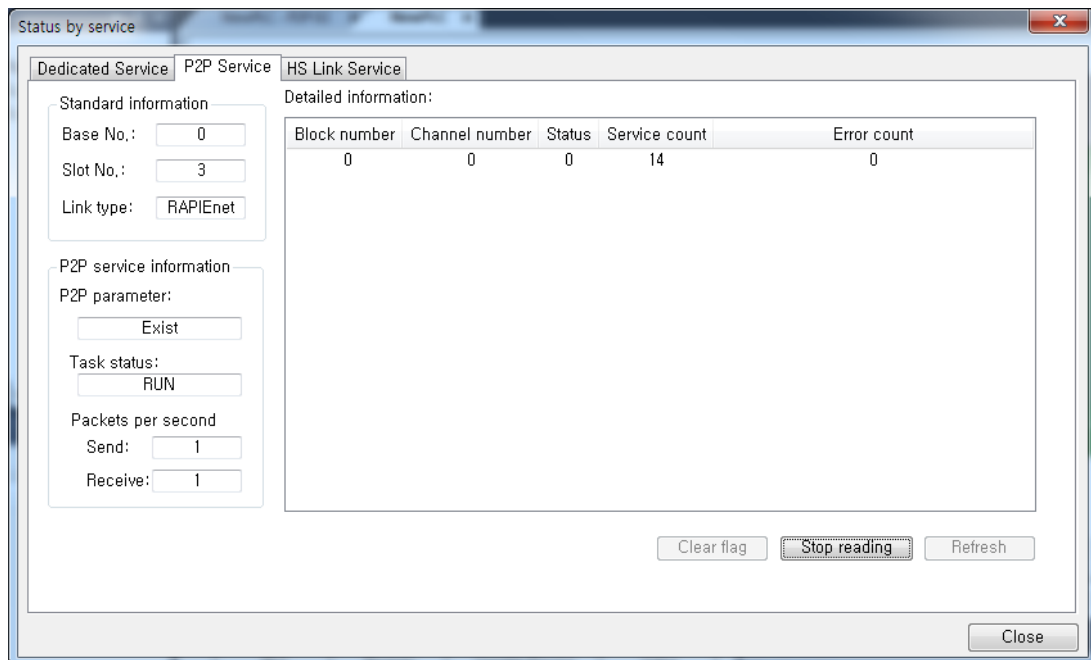

[Fig. 7.5.2] P2P status for respective services

Chapter 8 Remote Connection Service

8.1 Introduction

This function is used for programming, downloading of user program, program debugging, monitoring, etc in network system where PLCs are connected with each other via RAPIEnet I/F module by remote control without moving the physical connection status of XG5000. It is especially convenient for easy access to each device from a place without repositioning when network-connected devices are separated far. XG5000 remote connection service is available under the following Logical Path to attain its purpose.

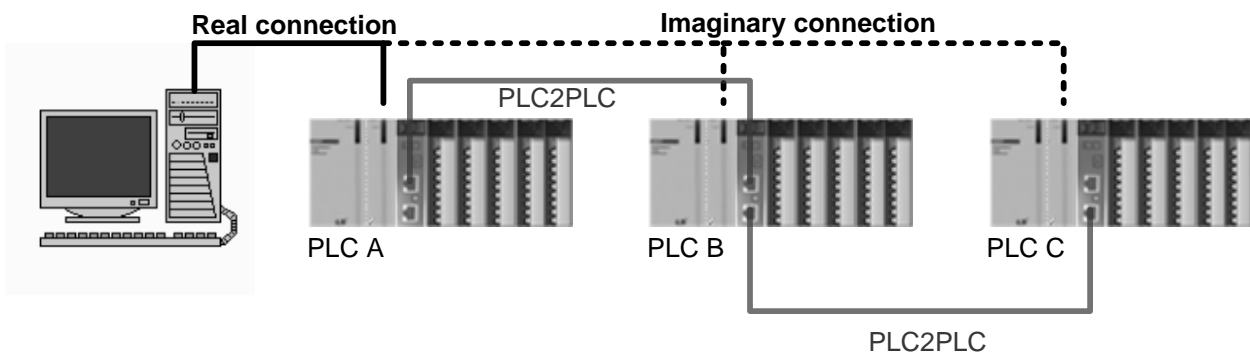

[Fig. 8.1.1] RAPIEnet network

A network is supposed where RS-232C cable is connected between PC in which XG5000 is installed and PLC #1 station, and PLC #1, PLC #2 and PLC #n are connected with each other via RAPIEnet in XG5000 of [Fig.8.1.1]. To access the contents of PLC #1 station in the figure above, Local connection is needed in XG5000's on-line menu. After finishing accessing the contents of PLC #1, disconnect the Local connection with 'Disconnect' menu. To access the PLC #n station, select PLC #n by setting the Base and Slot No. where RAPIEnet module is installed in the PLC #1 station in the remote connection dialog box and connect. Then logical connection between XG5000 and PLC #n will be established via RS-232C/USB and RAPIEnet. This status is identical to the status that RS-232C/USB cable is connected between PC and PLC #n station and it is available to execute all functions of programming, downloading, debugging and monitoring as in PLC #1. With the remote connection service of XG5000, easy access to PLC is possible even if the PLC is located at a far place. And re-programming without repositioning the PLC is possible when PLC is located at a place hard to reach.

8.2 Setting and Connection

All PLCs connected via XGT network are available to connect with each other by remote connection service. XG5000 remote connection is composed of stage 1 and stage 2 connections as described below.

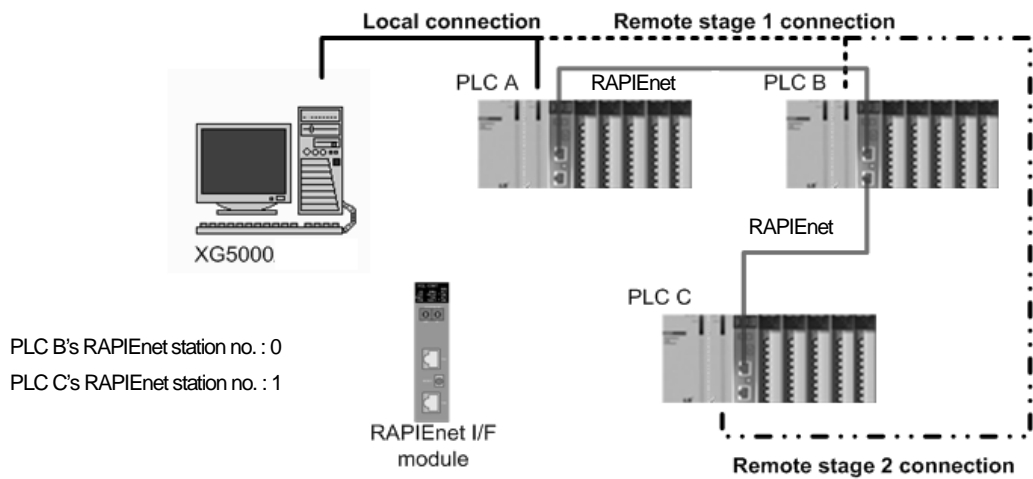

[Fig. 8.2.1] Remote connection

[Fig. 8.2.1] shows an example remote stage 1/2 connection in the network system composed of two networks.

8.2.1 Remote 1 connection

For remote stage 1 connection, XG5000 shall be in off-line state.

At this state, Select "Online-Connection Settings"

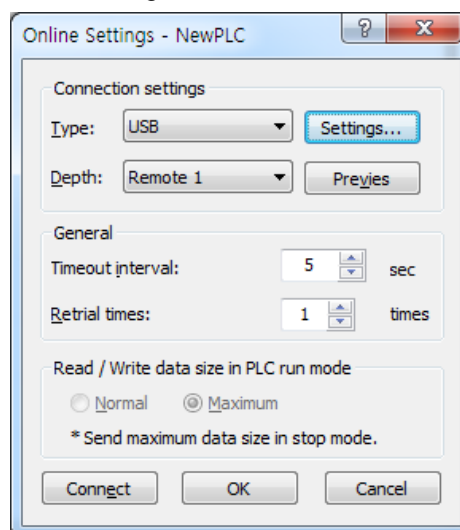

[Fig. 8.2.2] XG5000 remote connection option to select

Item		Details
Connection settings	Type	Selects a connection media(RS-232C or USB)
	Depth	1) Local: connection of PC and CPU 2) Remote 1: connection stage 1 via comm. module 3) Remote 2: connection stage 2 via comm. module
General	Timeout interval	Setting Timeout interval in case of connection CPU (1~9s)
	Retrial times	Retrial times to connect CPU (0~9)

Set the depth in connection settings to "Remote 1". Then, click "Settings" button and set each item in details window.

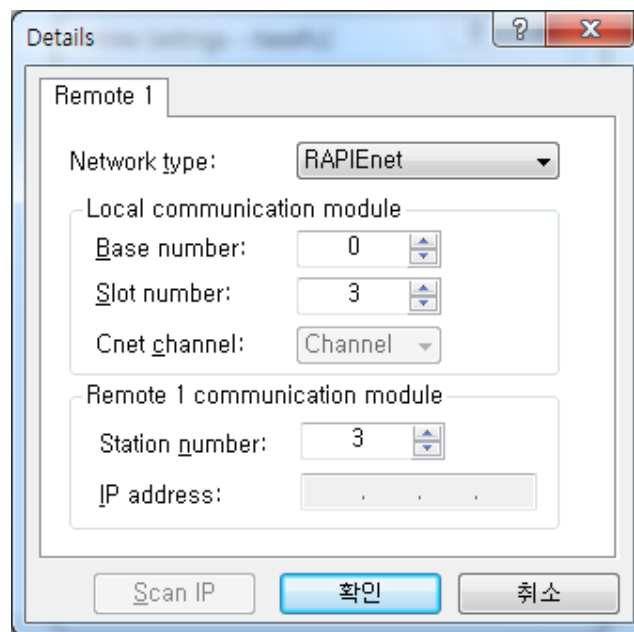

[Fig. 8.2.3] Detail setting window

Item		Details
Network type		Select a network type For RAPIEnet I/F module, select RAPIEnet.
Local communication module	Base number	Select base number of a communication module at the local PLC for remote 1 connection
	Slot number	Select slot number of a communication module at the local PLC for remote 1 connection
Remote 1 communication module	Station number	Select station number of communication module at remote 1 (Station number of PLC B at [Figure 8.2.1] is 0)

If you click the “Preview” at the “Online Settings” window, you can check the remote 1 connection setting

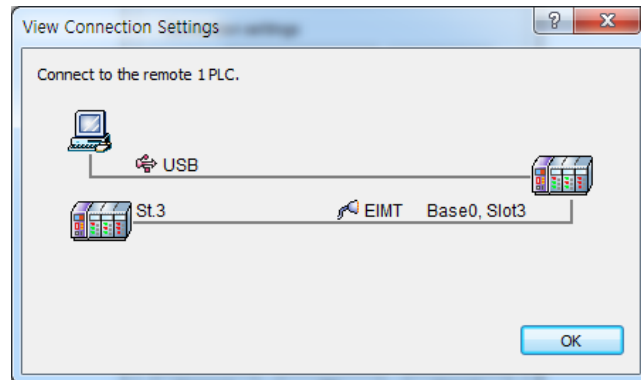

[Figure 8.2.4] View Connection Settings window

If setting is complete, exit from an option window and execute online connection

In case of the connection failure, the following message appears.

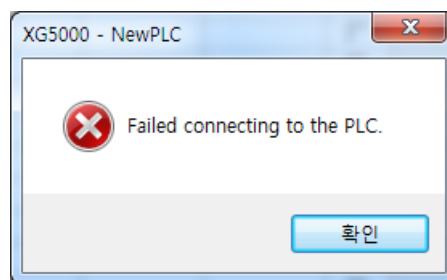

[Figure 8.2.5] Connection failure window

(This appears when connection setting or line is abnormal.)

When CPU type of the connected PLC is different from that of the currently opened project, the following message appears. Correct the CPU type.

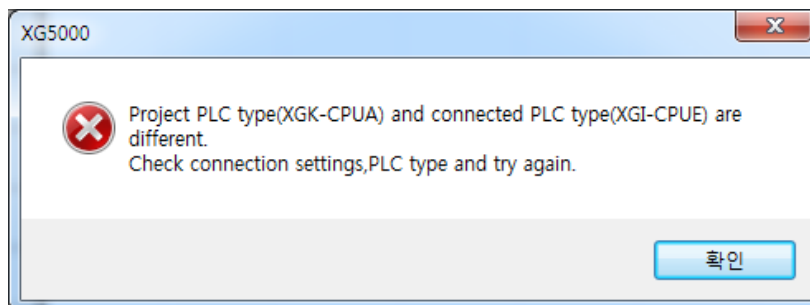

[Figure 8.2.6] In case of PLC type mismatch

Remote 1 connection state is same as the connection state connecting RS-232C cable to the target PLC of remote connection 1. You can use all items in the online menu.

8.2.2 Remote 2 connection

For remote 2 connection, XG5000 is connected through PLC A's RAPIEnet → PLC B's RAPIEnet → PLC C's RAPIEnet

For remote stage 2 connection, XG5000 shall be in off-line state.

At this state, Select "Online-Connection Settings" and select "Remote 2" at Depth.

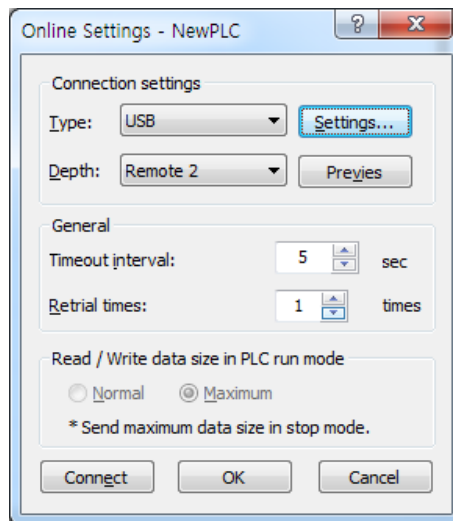

[Figure 8.2.7] Online Settings window

Click "Settings" at Remote 2.

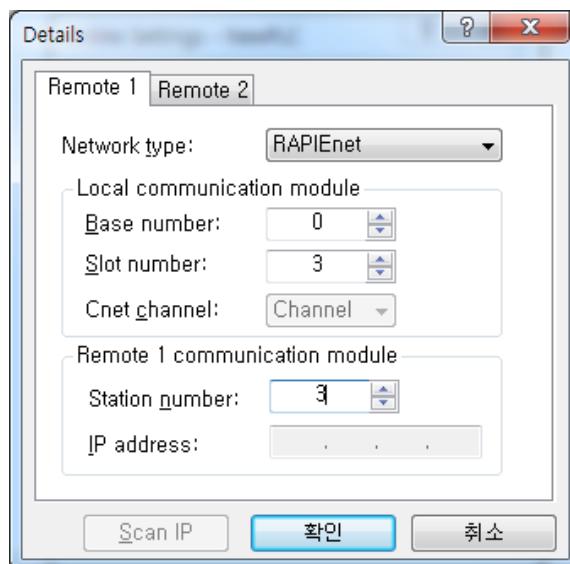

[Fig. 8.2.8] Details window: remote 1

Set a "Remote 1" tab

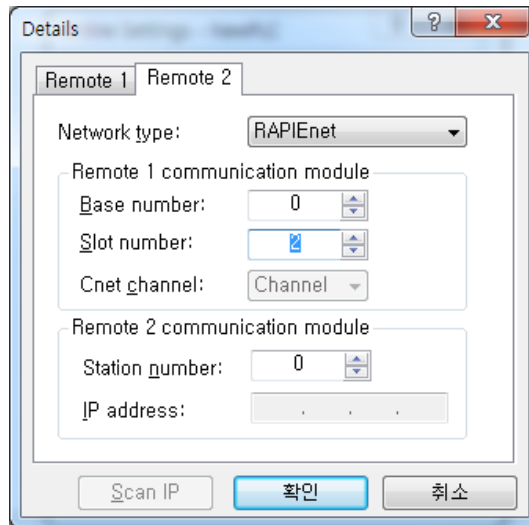

[Figure 8.2.9] Details window: remote 2

Set a "Remote 2" tab

Items		Details
Network type		Select a network type For RAPIEnet I/F module, select RAPIEnet.
Remote 1 communication module	Base number	Base number of the communication module at remote 1
	Slot number	Slot number of the communication module at remote 1
Remote 2 communication module	Station number	Station number of the communication module at remote 2

You can check your settings through "Preview" button of [Figure 8.2.7]

In case you set as above, "Preview" window is as follows.

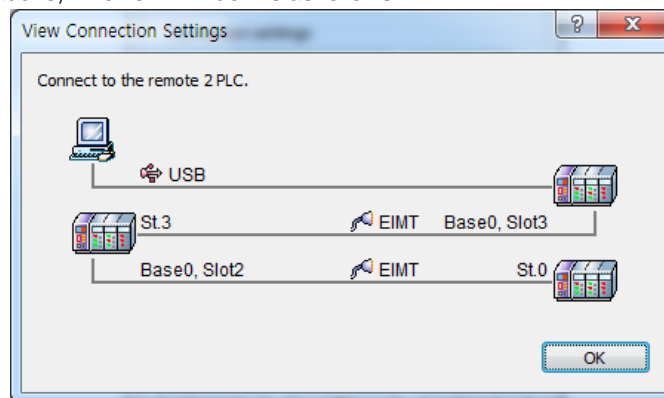

[Figure 8.2.10] Preview window of remote 2 connection

If setting is complete, exit from an option window and execute online connection

Remote 2 connection state is same as the connection state connecting RS-232C cable to the target PLC of remote connection 2. You can use all items in the online menu.

Chapter 9 Example Program

9.1 High Speed Link Program

9.1.1 High Speed Link parameter setting

Describes how to set HS link parameter at XGnet I/F system

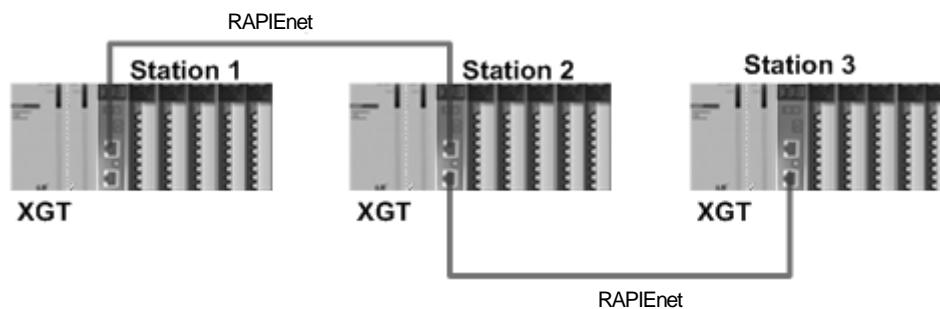

[Fig. 9.1.1] I/O configuration and TRX data

TRX structure		I/O configuration (All stations are same)	TX area	RX area
XGT(1)	TX	slot 0 : RRAPIEnet slot 1 : output 32 slot 2 : input 32	%PW8 (2 words)	--
	RX : <-- XGT 2		--	%MW0(2words)
XGT(2)	TX		%PW8 (2words)	--
	RX : <-- XGT 3		--	%MW0(2words)
XGT(3)	TX		%PW8 (2words)	--
	RX : <-- XGT 1		--	%MW0(2 words)

[Table 9.1.1] I/Oconfiguration and TRX data

(1) HS link parameter setting

In order to communicate like [Table 9.1.1] at the system like [Fig. 9.1.1], write data TRX map like [Table 9.1.1].

Write HS link parameter and download it to PLC for communication like [Table 9.1.1]

Start the HS link by the following sequence.

- (a) Connect XG5000 to XGT CPU and set standard parameter
- (b) Write data TRX map
- (c) Set parameter at Hs link parameter setting item of XG5000
- (d) Execute 'Write' on Online menu.
- (e) Execute 'Enable Link' on [Online]-[Communication module setting] menu.
- (f) Check the status of HS link by using system diagnosis service of XG5000
- (g) If there's error, execute again from Step (a)

Chapter 9 Example Program

Set HS link parameter for example system as shown below

Select one among 12 HS link parameters at HS link setting screen like [Fig. 9.1.2] and register the module

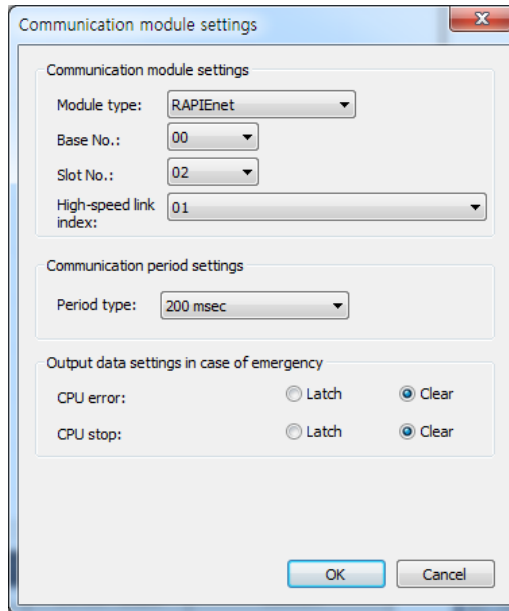

[Fig. 9.1.2] Communication module and period setting

Set Module type as RAPIEnet and define Base Number and Slot Number. After setting HS link, set TRX parameter from index 0. For example, in case of XGT station no. 1, it consists of TX block 0 and RX block 0. After setting TRX area according to TRX data map, set communication period according to “6.6.2 High Speed Link speed calculation”. Here it is set as default value 200ms. [Fig. 9.1.3]~[Fig.9.1.5] shows results of parameter setting at XG5000.

Index	Mode	Station number	Block number	Read area	Read area Word size	Save area	Save area Word size
0	Send		0	P0008	2		
1	Receive	2	0			M0000	2
2							
3							
4							

[Fig 9.1.3] HS link block setting of XGT station no.1

Index	Mode	Station number	Block number	Read area	Read area Word size	Save area	Save area Word size
0	Send		0	P0008	2		
1	Receive	3	0			M0000	2
2							
3							
4							
5							

[Fig. 9.1.4] HS link block setting of XGT station no.2

Index	Mode	Station number	Block number	Read area	Read area Word size	Save area	Save area Word size
0	Send		0	P0008	2		
1	Receive	1	0			M0000	2
2							
3							
4							
5							

[Fig. 9.1.5] HS link block setting of XGT station no.3

In case HS link is under operation, if user download HS link parameter, Enable Link is canceled automatically and it is set after download.

(2) Write Parameter

On XG5000, select 'Online' → 'Write' and check relevant HS link and press OK.

[Fig. 9.1.6] is screen of 'Write Parameter'.

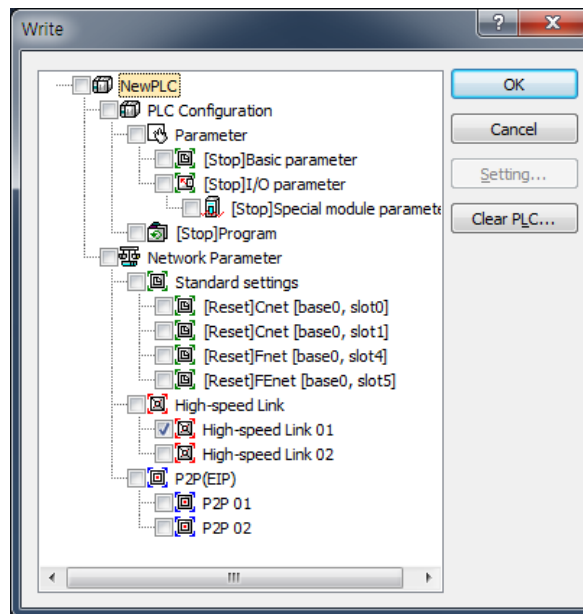

[Fig. 9.1.6] Screen of 'Write Parameter': High Speed Link

Write parameters about XGT system station no.1,2,3

(3) Enable Link

Select 'Online' → 'Communication module setting' → 'Enable Link' and check relevant HS link and click 'Write' button

[Fig. 9.1.7] is screen of 'Enable Link'

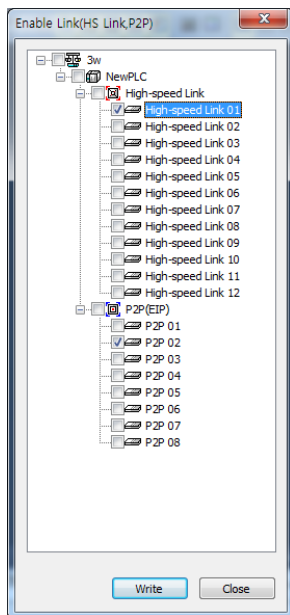

[Fig. 9.1.7] screen of Enable Link: HS link

Write parameters about XGT system station no.1,2,3

9.1.2 How to set HS link speed

Above example is simple system where each 3 stations sends/receives 2 word data. So TRX period can be calculated according to "6.4.2 High Link Speed calculation"

Namely, expression $St = P_Scan1 + C_Scan + P_Scan2$

(St = HS link Max. TX time

P_Scan1 = Max. program scan time of PLC station no. 1

P_Scan2 = Max. program scan time of PLC station no. 2

C_Scan = Max. communication scan time)

At above expression, P_Scan1, P_Scan2 is scan time of XGT PLC and we will assume that is 5ms respectively.

(See Online/PLC Information/Performance for accurate scan time)

Expression $C_Scan = Th \times Sn$

(Th = data TX time per one station at media (IEEE 802.3 specification)

Sn = Total Station Number)

At above expression, Sn=3, Th =2.3ms so C_Scan=6.9ms.

$St = P_Scan1(=5\text{ ms}) + P_Scan2(=5\text{ ms}) + C_Scan(6.9\text{ ms}) = 16.9\text{ ms}$ and minimum TRX period should be 17ms or above.

9.1.3 High Speed Link Diagnosis service

To check if system is normal, at 'System Diagnosis', click XGnet I/F module with right button of mouse and select 'Status by Service' and open 'HS Link service' tap.

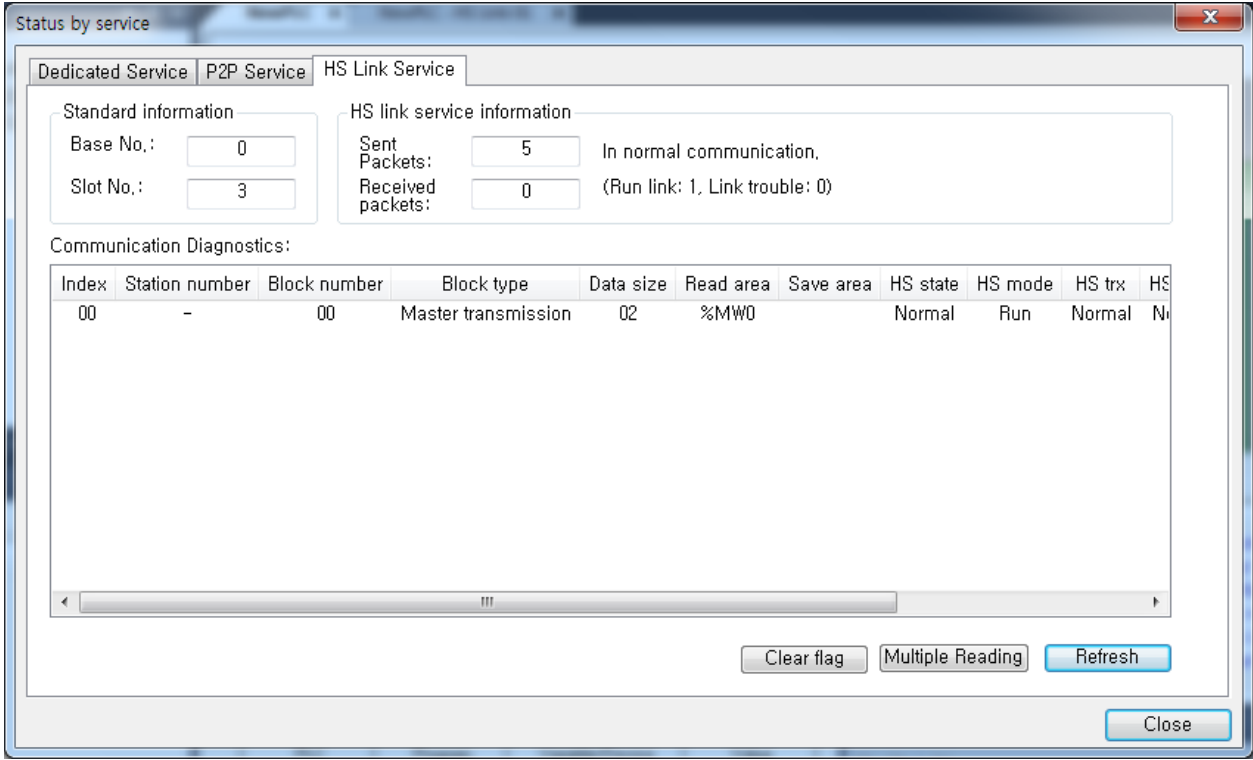

[Fig. 9.1.8] Screen of 'Status by Service': HS link service

9.2 P2P Program

9.2.1 P2P parameter setting

At XGT XGnet I/F system configured as figure below, station 1 is master. Here describes how to set P2P parameter for data communication as the following I/O structure.

But, We will assume that all stations are normal.

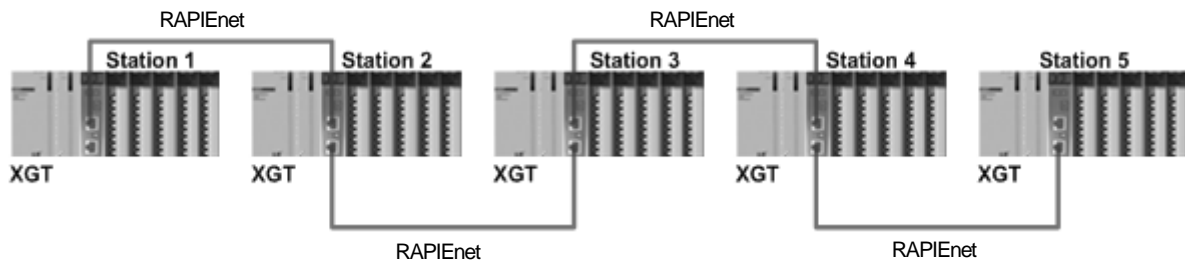

[Fig. 9.2.1] I/O configuration and TRX data

Station	Partner	Operation point	Operation	Details
1	2	Bit 2 of F9	READ	Read %MW10, 20, 30 and save %MW0, 1, 2
2	3	Bit 3 of F9	READ	Read 10 Word from %MW100 and save %MW10
3	4	Bit 0 of M5	WRITE	Read %MW0, 1, 2 and save %MW10, 20, 30
4	5	Bit 3 of M6	WRITE	Read 10 Word from %MW10 and save %MW100

[Table 9.2.1] I/O configuration and TRX data

- (1) Execute XG5000 and connect to CPU of XGT station 1
- (2) To register P2P service, register RAPIEnet module by using “Online – Diagnosis – I/O Information – I/O Sync”
- (3) Select P2P parameter window and register RAPIEnet module at P2P 2

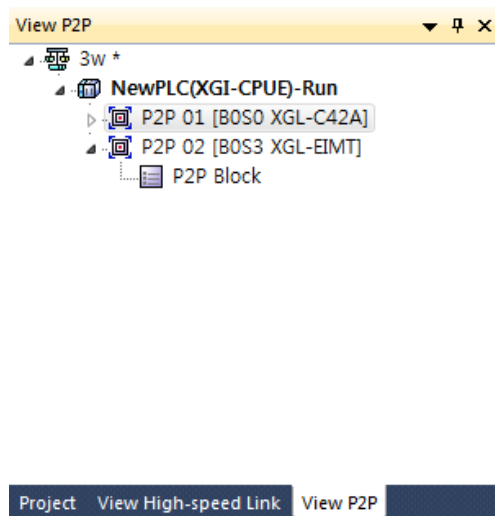

[Fig. 9.2.2] P2P project window setting

- (4) Register P2P parameter defined at P2P block setting window.
 (a) 1: When %IX0.0.2 is set, read %MW10, 20, 30 of partner 2 and save them at %MW0, 1, 2 of self station

Index	P2P function	Conditional flag	Data type	No. of variables	Destination station	Destination station number	Setting	Variable setting contents
0	READ	%IX0.0.2	WORD	3	<input checked="" type="checkbox"/>	2	Setting	Number:3 READ1:%MW10,SAVE1:%MW0,SIZE1:1 READ2:%MW20,SAVE2:%MW1,SIZE2:1 READ3:%MW30,SAVE3:%MW2,SIZE3:1
1					<input type="checkbox"/>		Setting	
2					<input type="checkbox"/>		Setting	

[Fig. 9.2.3] P2P block setting: 1

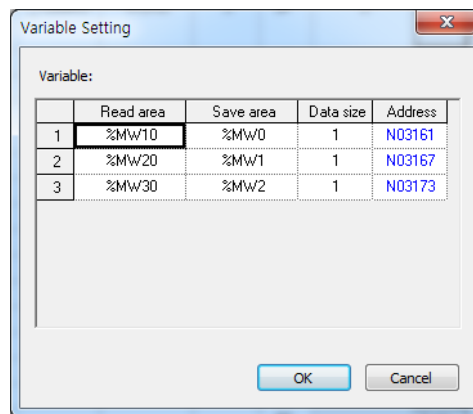

[Fig. 9.2.4] P2P variable setting: 1

- (b) 2: %FX147 is set, read 10 words from %MW100 of station 3 and save them at %MW10

Index	P2P function	Conditional flag	Data type	No. of variables	Destination station	Destination station number	Setting	Variable setting contents
0	READ	%FX147	WORD	1	<input checked="" type="checkbox"/>	3	Setting	Number:1 READ1:%MW10,SAVE1:%MW100,SIZE1:10
1					<input type="checkbox"/>		Setting	
2					<input type="checkbox"/>		Setting	

[Fig. 9.2.5] P2P block setting: 2

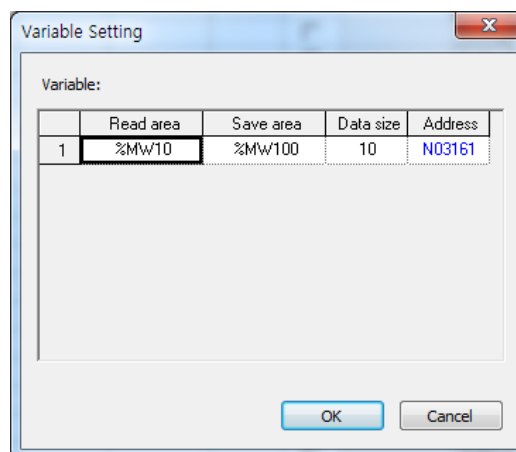

[Fig. 9.2.6] P2P variable setting: 2

(c) 3: When %QX0.0.5 is set, read %MW0, 1, 2 of self station and save them at %MW10, 20, 30 of partner 4

Index	P2P function	Conditional flag	Data type	No. of variables	Destination station	Destination station number	Setting	Variable setting contents
0	WRITE	%QX0.0.5	WORD	3	<input checked="" type="checkbox"/>	4	Setting	Number:3 READ1:%MW0,SAVE1:%MW10,SIZE1:1 READ2:%MW1,SAVE2:%MW20,SIZE2:1 READ3:%MW2,SAVE3:%MW30,SIZE3:1
1					<input type="checkbox"/>		Setting	
2					<input type="checkbox"/>		Setting	

[Fig. 9.2.7] P2P block setting: 3

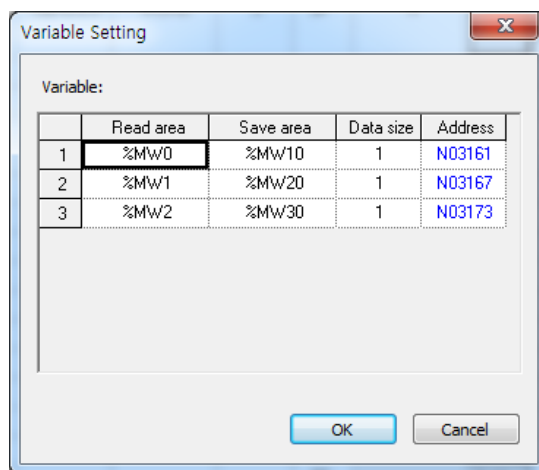

[Fig. 9.2.8] P2P variable setting: 3

(d) 4: When %RX10 is set, read 10 words from %MW10 and save them %MW100 of partner 5

Index	P2P function	Conditional flag	Data type	No. of variables	Destination station	Destination station number	Setting	Variable setting contents
0	WRITE	%RX10	WORD	1	<input checked="" type="checkbox"/>	5	Setting	Number:1 READ1:%MW10,SAVE1:%MW100,SIZE1:10
1					<input type="checkbox"/>		Setting	
2					<input type="checkbox"/>		Setting	

[Fig. 9.2.9] P2P block setting: 4

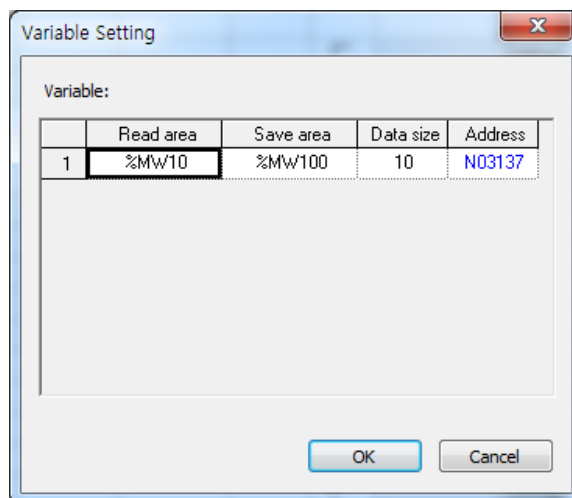

[Fig. 9.2.10] P2P variable setting: 4

(5) Download P2P parameter

Select “Online – Write” of XG5000 and download P2P parameter to start service among the registered P2P parameter

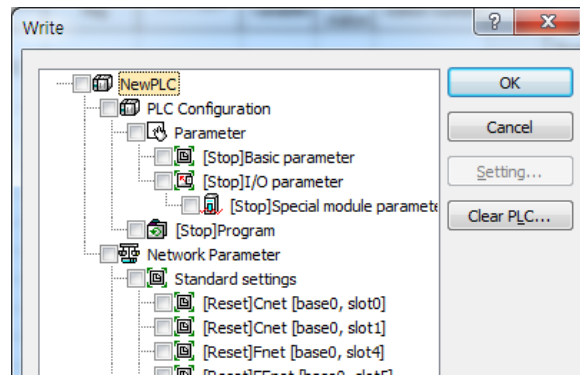

[Fig. 9.2.10] Screen of Write Parameter: P2P

The downloaded P2P parameter is backed up regardless of power

(6) Enable P2P link

Though P2P parameter is downloaded normally, P2P service doesn't start. The user has to notify the operation. Activate P2P service by using “Online – Communication module setting - Enable Link” of XG5000.

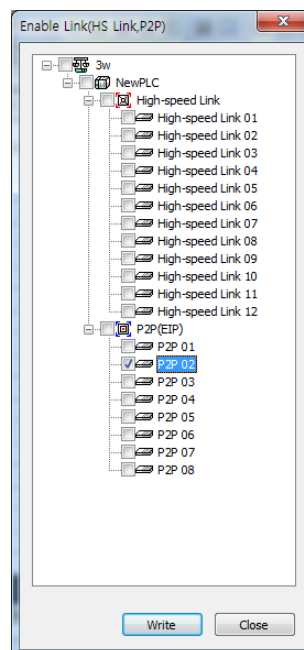

[Fig. 9.2.11] Screen of Enable Link: P2P

The started P2P service holds its status though power is off or reset

9.2.2 P2P Diagnosis

To check if system is normal, at 'System Diagnosis', click XGnet I/F module with right button of mouse and select 'Status by Service' and open 'P2P service' tap.

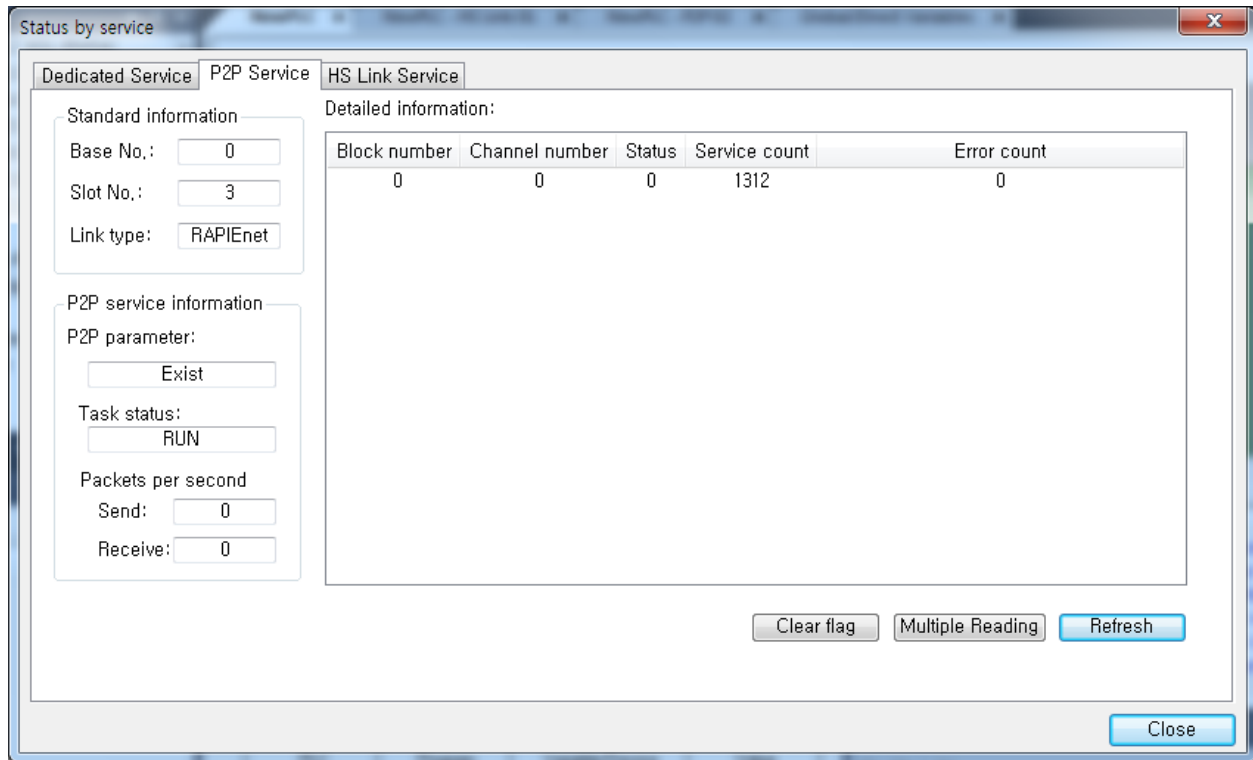

[Fig. 9.2.12] Screen of status by service: P2P service

9.3 MRS setting example

9.3.1 Communication parameter setting

- (1) Run XG5000.
- (2) Select MRS module. Setting Station(0 ~ 63) (Another parameter setting is provided Next O/S version.)

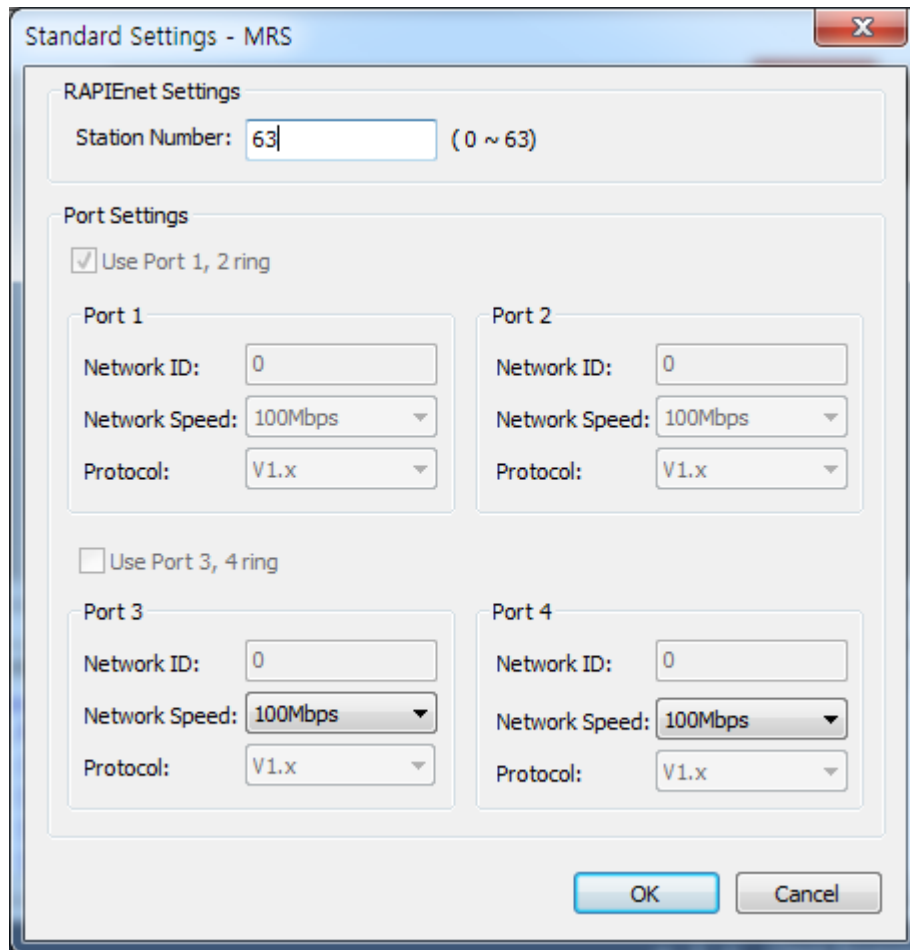

[Fig 9.3.1] MRS Basic parameter

- (3) Download parameter through XG5000.
- (4) After download parameter, reset module.

9.3.2 Check system operation

- (1) Check LED Status
- (2) When module is fault, check diagnosis in manual

Chapter 10 Diagnostic Function

This chapter describes the methods of investigating the statuses of the system, Modules, and network, and downloading OS. The system configuration and the status of RAPIEnet I/F Module can be checked with following procedures. The downloading method of RAPIEnet I/F Module OS is provided in this chapter.

10.1 System diagnosis

The statuses of RAPIEnet I/F Module and system can be investigated with this method. In the XG5000 screen, select 'Online' → 'Connect' to access PLC, and select 'Online' → 'Communication module setting' → 'System Diagnosis.' The local system diagnosis window will appear as shown in [Fig. 10.1.1] and the Module information window will appear beneath the system diagnosis window, as shown in [Fig. 10.1.2].



[Fig. 10.1.1] System diagnosis window

System information	Allocation information - Fixed	Comment
Base 0 : XGB-M12A		Main Base(12 Slots)
Power: XGP-ACF		AC100~240V Input
CPU: XGI-CPUE		Economic CPU Module(I/O: Maximum 1,536 Points)
Slot 0: XGL-C42A		Cnet Module, RS-422/RS-422
Slot 1: XGL-CH2A		Cnet Module, RS-232C/RS-422
Slot 2: XGL-RMEA		Rnet Module, Rnet Master
Slot 3: XGL-EIMT		RAPIEnet Module, Electrical Master
Slot 4: XGL-FMEA		Fnet Module, Fnet Master
Slot 5: XGL-EFMT		Fast Ethernet Module, Electrical Master
Slot 6: XGL-EIMT		RAPIEnet Module, Electrical Master
Slot 7: Empty slot		
Slot 8: Empty slot		
Slot 9: Empty slot		

[Fig. 10.1.2] Module information tap

Chapter 10 Diagnostic Function

When connected with extension bases, click the extension base on the Module information window to switch to the system diagnosis window of the extension base. The [Fig. 10.1.1] and [Fig. 10.1.2] above show the main base system diagnosis window of a system consisted with main base and extension bases. In the above system, select the Base 1 in [Fig.10.1.2] to view the extension base diagnosis window in [Fig. 10.1.3].



[Fig. 10.1.3] Extension base diagnosis window

System information	Allocation information - Fixed	Comment
<ul style="list-style-type: none"> Base 0 : XGB-M04A Base 1 : XGB-E06A <ul style="list-style-type: none"> Power: XGP-ACF 0 Slot 0: XGL-EIMT 1 Slot 1: XGL-EIMT 2 Slot 2: XGL-EIMT 3 Slot 3: XGL-EIMT 4 Slot 4: XGL-EIMT 5 Slot 5: Empty slot 		<ul style="list-style-type: none"> Main Base(4 Slots) Expansion Base(6 Slots) AC100~240V Input RAPIDnet Module, Electrical Master RAPIDnet Module, Electrical Master RAPIDnet Module, Electrical Master RAPIDnet Module, Electrical Master RAPIDnet Module, Electrical Master

[Fig. 10.1.4] Extension base module information window

10.2 Communication Module information

10.2.1 XGL-EIMx

This shows the basic information on the RAPIEnet I/F MODULE. In the system diagnosis window, click the RAPIEnet I/F MODULE whose communication module information you want to view, and select 'Detailed Module Information.' The Communication Module Information window appears as shown in [Fig. 10.2.1].

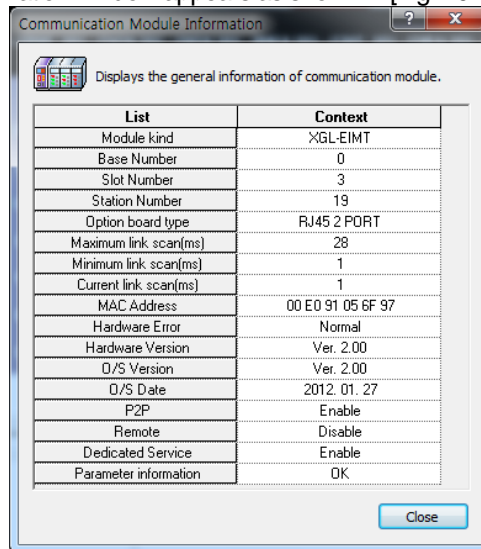

[Fig. 10.2.1] Communication Module Information window

Classification	Detail Classification	Description
Basic Information	Module kind	Indicates module type: RAPIEnet
	Base Number	Indicates the base location of the installed module - Range of indication: 0 ~ 7
	Slot Number	Indicates the slot location of the installed module - Range of indication: 0 ~ 11
Link Information	Station Number	Indicates module's station No. - Range of indication: 0 ~ 63
	Option board type	Indicates type of option board - TP 2 ports: electrical 2 ports - HYBRID: optical 1 port, electrical 1 port - FIBER 2 ports: optical 2 ports
	Max. link scan	Max. task execution time of OS (ms)
	Min link scan	Min. task execution time of OS (ms)
	Current link scan	Current task execution time of OS (ms)
	MAC address	Indicates MAC address
Hardware / Software information	Hardware Error	Hardware status of communication module
	Hardware Version	Hardware version of communication module
	O/S Version	OS version of communication module
	O/S Date	Date of OS version
Run mode Additional Information	P2P	P2P service status (Enable / Disenable)
	Remote	Remote connection status (Enable / Disenable)
	Dedicated Service	Dedicated service status (Enable / Disenable)
System parameter setting information	Parameter information	Error information of standard communication parameter

10.2.2 XGL-ES4T

This shows the basic information on the MRS I/F MODULE. In the system diagnosis window, click the MRS I/F MODULE whose communication module information you want to view, and select 'Communication Module Information.' The Communication Module Information window appears as shown in [Fig. 10.2.2].

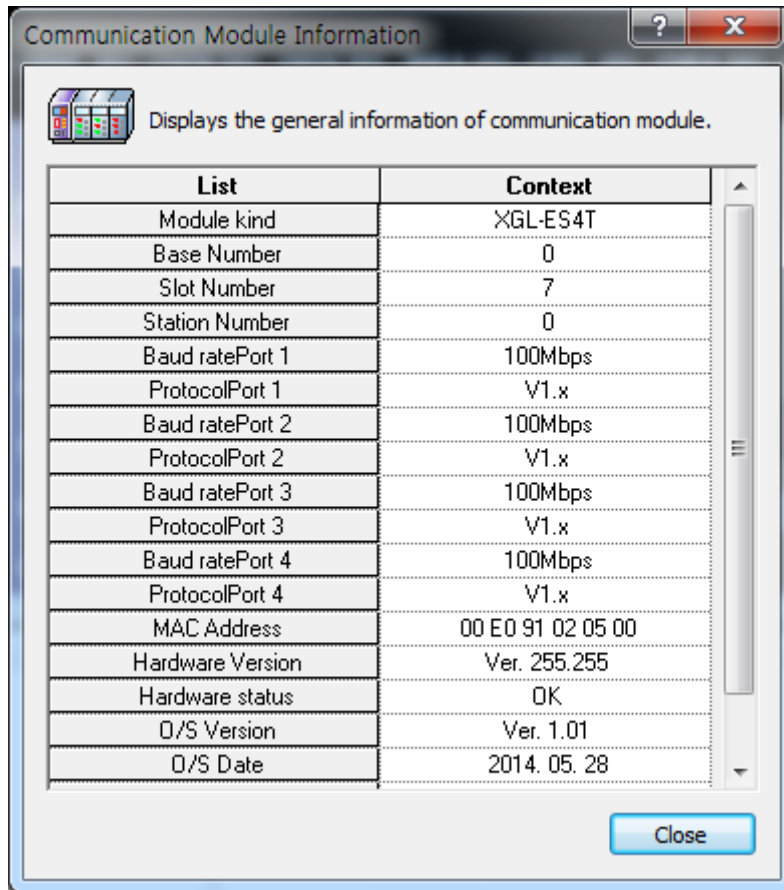

[Fig 10.2.2] Communication Module Information

Detail Classification	Description
Module kind	Indicates module type: MRS
Base Number	Indicates the base location of the installed module - Range of indication: 0 ~ 7
Slot Number	Indicates the slot location of the installed module - Range of indication: 0 ~ 11
Station Number	Indicates module's station No. - Range of indication: 0 ~ 63
Baud rate(Port x)	Indicates communication speed(Port x)
Protocol(Port x)	Indicates Protocol(Provided further)
MAC Address	Indicates MAC address
Hardware Version	Indicates hardware version
Hardware status	Indicates hardware status
O/S Version	Indicates O/S version
O/S Date	Indicates O/S date
O/S Type	Indicates O/S type
System parameter information	Determine whether the default parameter

10.3 Auto Scan

This function checks the configuration and module status of the network system constructed with RAPIEnet I/F MODULE and measure cable distance.

10.3.1 Auto scan

You can check the network system configuration of the entire system. In the system diagnosis window, right-click the RAPIEnet I/F MODULE for which the auto scan is to be conducted, select 'Auto Scan.' The Auto Scan window will appear as shown in [Fig. 10.3.1].

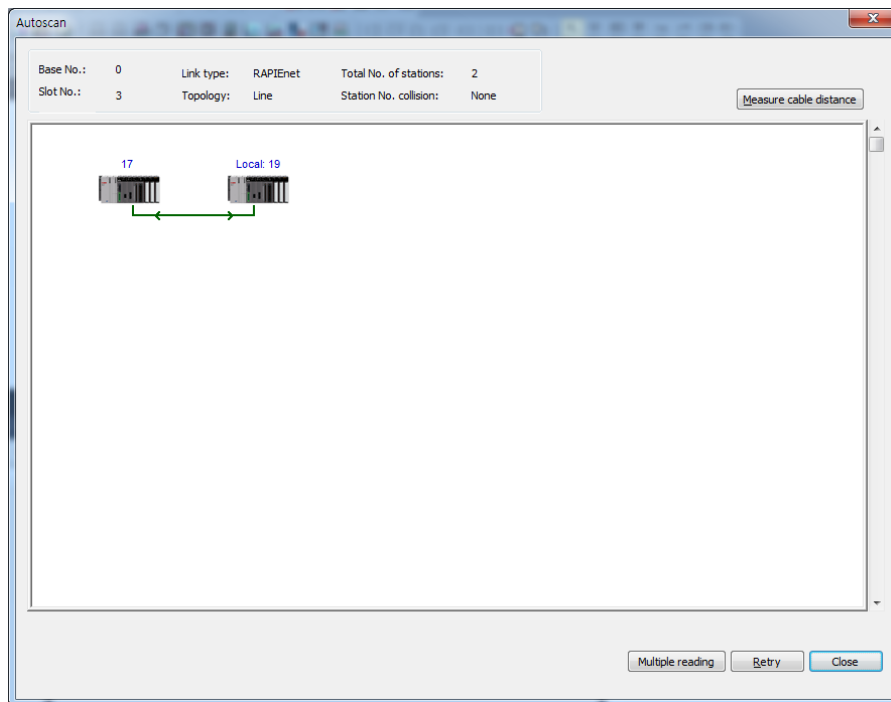

[Fig. 10.3.1] Auto Scan window

The text information on the top of the Auto Scan window is as follows;

Item	Description
Base No.	Indicates the base location of the local RAPIEnet I/F MODULE - Range of indication: 0 ~ 7
Slot No.	Indicates the slot location of the local RAPIEnet I/F MODULE - Range of indication: 0 ~ 11
Link Type	Indicates the network type of the local RAPIEnet I/F MODULE: PLC2PLC
Topology	Shows network configuration of the system - LINE: line-type network configuration - RING: ring-type network configuration
Total No. of stations	Total No. of the RAPIEnet I/F Modules on the network - Range of indication: 0 ~ 63
Station No. conflict	Shows the duplicate station No. of 2 or more of the modules on the network

You can check the network system configuration of the entire system. In the system diagnosis window, right-click the MRS I/F MODULE for which the auto scan is to be conducted, select 'Auto Scan.' The Auto Scan window will appear as shown in [Fig. 10.3.2].

Chapter 10 Diagnostic Function

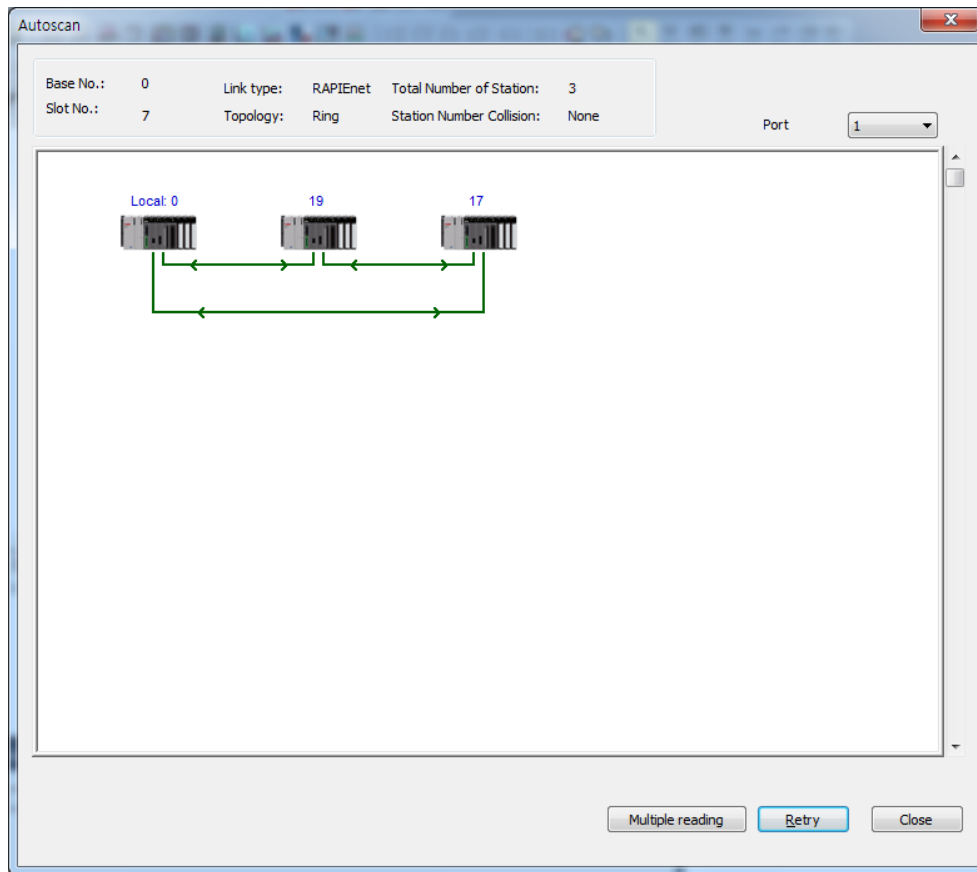

[Fig 6.3.2] Auto Scan window

The text information on the top of the Auto Scan window is as follows;

Item	Description
Base No.	Indicates the base location of the local RAPIEnet I/F MODULE - Range of indication: 0 ~ 7
Slot No.	Indicates the slot location of the local RAPIEnet I/F MODULE - Range of indication: 0 ~ 11
Link Type	Indicates the network type of the local RAPIEnet I/F MODULE: PLC2PLC
Topology	Shows network configuration of the system - LINE: line-type network configuration - RING: ring-type network configuration
Total No. of stations	Total No. of the RAPIEnet I/F Modules on the network - Range of indication: 0 ~ 63
Station No. conflict	Shows the duplicate station No. of 2 or more of the modules on the network
Port setting	Indicates the base location of the local RAPIEnet I/F MODULE - Range of indication: 1 ~ 4

10.3.2 Cable distance measurement

Throughout the entire network system, cable distance between the RAPIEnet I/F Modules can be measured. Select the 'Measure Cable Distance' on top of the Auto Scan window to look up the cable distance and the date of measurement, as shown in [Fig. 10.3.2]. Since the length of optical cables cannot be measured, "Fiber Optic" is indicated.

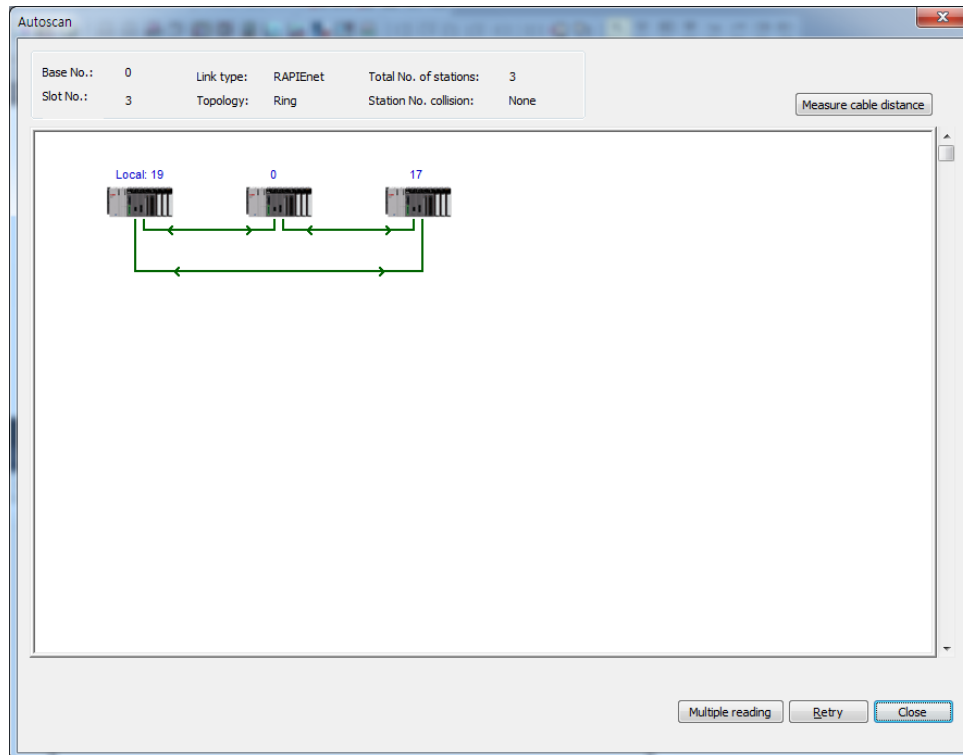

[Fig. 10.3.2] Auto Scan window showing cable distance measurement

Conduct followings to display cable length in advance. If following steps are not taken in advance, wrong lengths may be displayed.

< How to measure cable length >

- (a) Construct the system, connect cables.
- (b) Turn power on, check that all the link LEDs of the RAPIEnet I/F Modules connected with cables.
- (c) From the electrical ports of the modules whose Link LEDs are 'ON,' isolate cables, and reconnect after 5~10 seconds.
- (d) Conduct (c) hereinabove with all the modules whose cable lengths are to be measured. However, do not isolate both ends of cable.
- (e) Conduct 3) above for the cables lengths are to be measured. Select Measure Cable Distance in the Auto Scan window.

10.3.3 Diagnosis on the status information of remote modules

Diagnostic service can be provided for the modules having the station No. indicated on the Auto Scan.

In the Auto Scan window, select, with mouse right button, the icon of the station No. whose diagnostic service is to be viewed. The diagnostic service menu appears as shown in [Fig. 10.3.3].

Chapter 10 Diagnostic Function

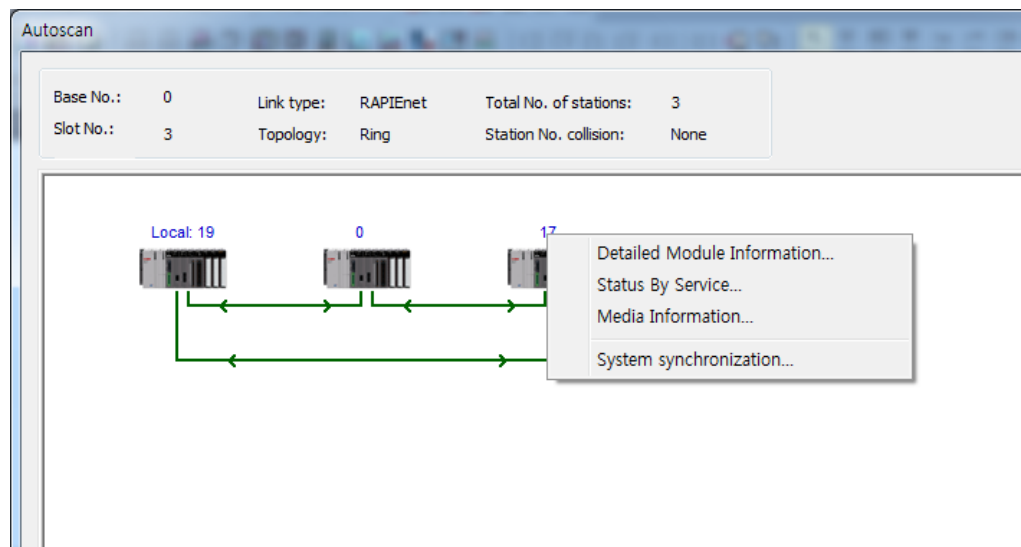

[Fig. 10.3.3] Remote diagnostic service menu window

(1) Remote communication module information

In the menu of [Fig. 10.3.3], select 'Detailed Module Information.' The remote communication module information window will appear as shown in [Fig. 10.3.4].

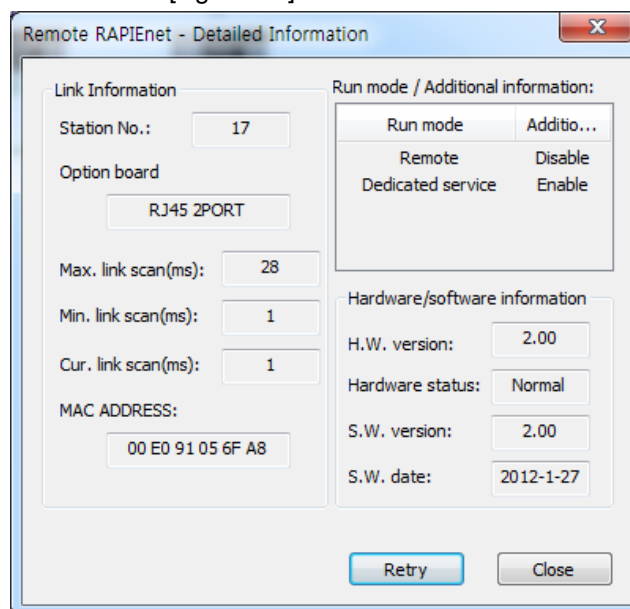

[Fig. 10.3.4] Remote communication module information window

For the details of the communication module information items in [Fig. 10.3.4], see 10. 2 Communication Module Information.

(2) Remote service statuses

Select 'Service Statuses' from the menu tree in [Fig. 10.3.3]. The Remote Service Status window will appear as shown in [Fig. 10.3.5].

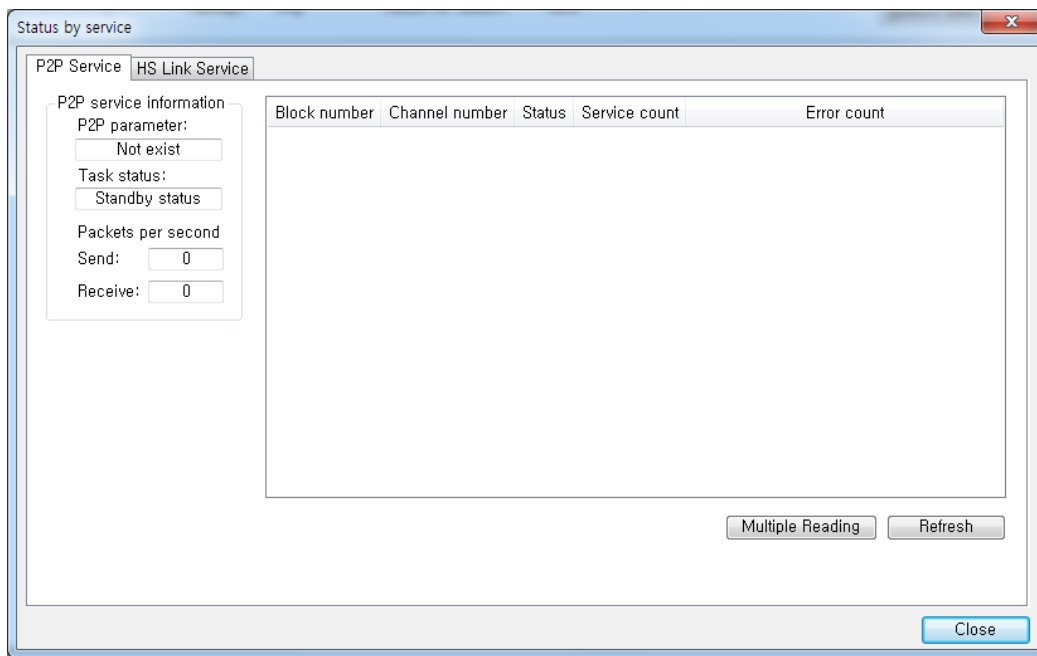

[Fig. 10.3.5] Remote Service Status window: P2P service

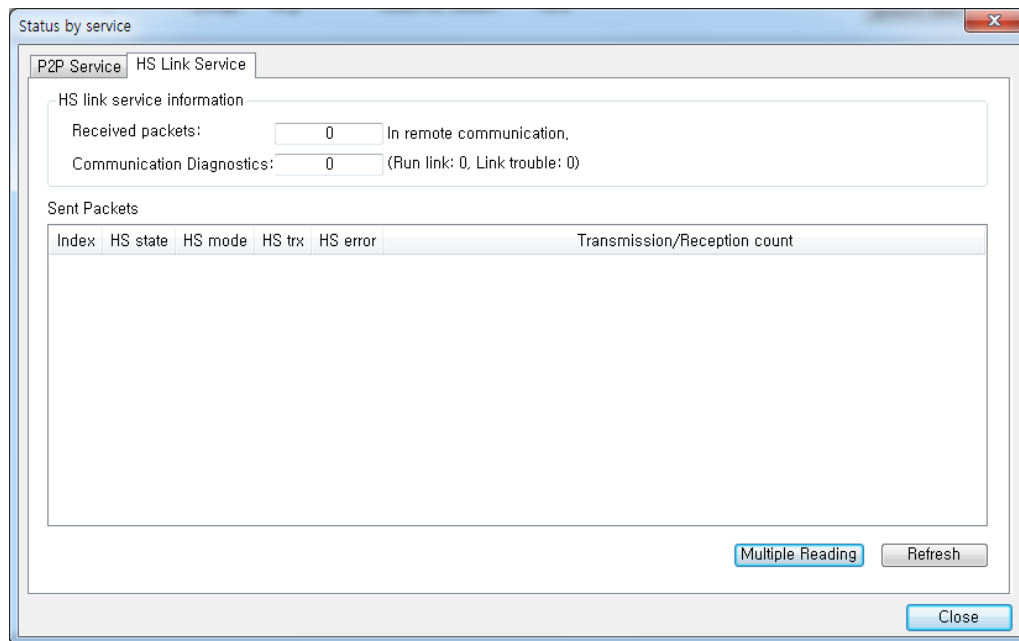

[Fig. 10.3.6] Remote Service Status window: high speed link service

For the details of the [Fig. 10.3.5] Service Status: P2P Service items, see Chapter 7. P2P Service, and for the details of [Fig. 10.3.6] Service Status: high speed link service items, see Chapter 6. High Speed Link Service.

(3) Remote media information

Select "Media Information" from the menu tree in [Fig. 10.3.3], the Remote Media Information window will appear, as shown in [Fig. 10.3.7].

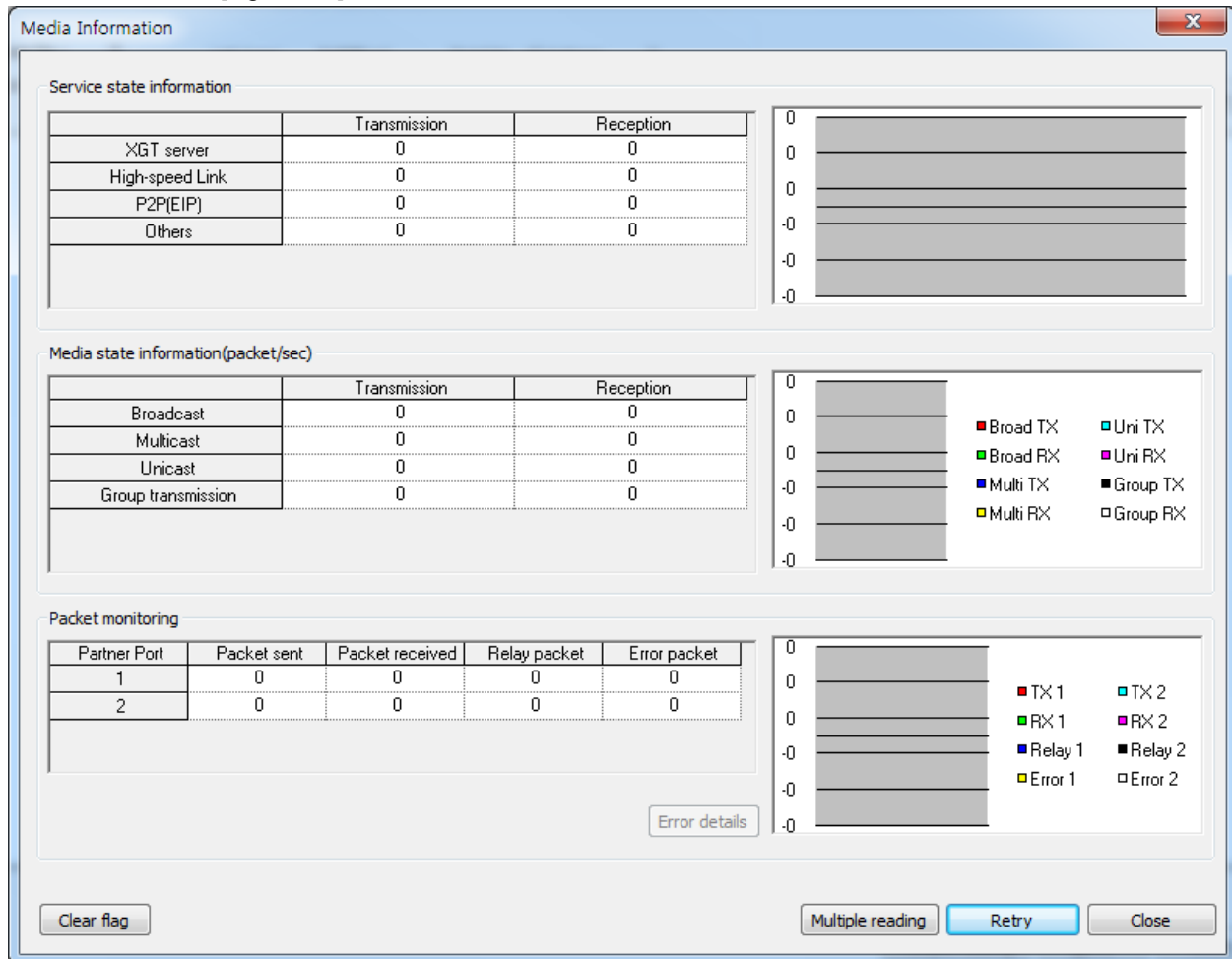

[Fig. 10.3.7] Remote Media Information window

For the details of the media information items in [Fig. 10.3.7], see 10.5 Media Information Diagnosis.

10.4 Media information diagnosis

This function checks the network media information of the RAPIEnet I/F Module.

10.4.1 Media information

The status of the service or media of the RAPIEnet I/F Modules can be checked with the number of packets.

In the system diagnosis window, right-click the RAPIEnet I/F Module whose media status is to be checked, and select Media Information. The media information window will appear as shown in [Fig. 10.5.1].

You can check the status information and packet monitoring on real-time-basis. Packet number can be checked in graphic.

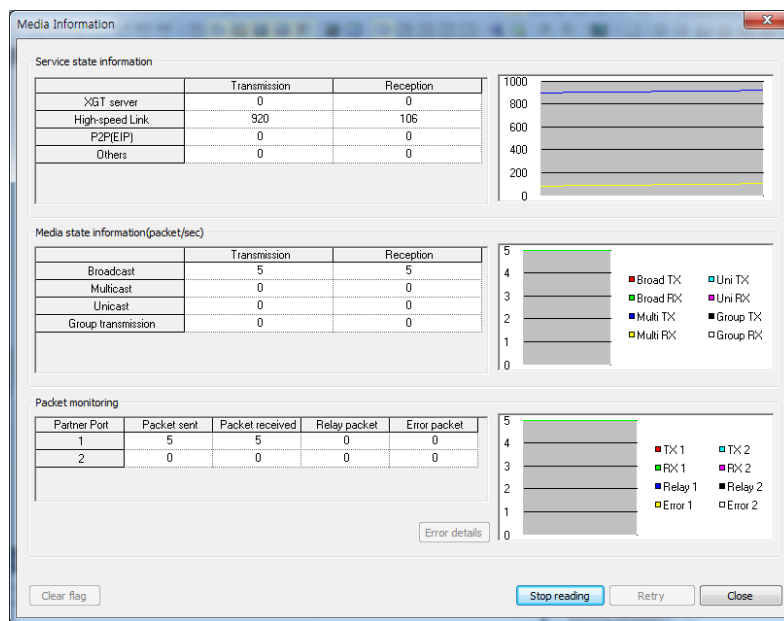

[Fig. 10.4.1] Media information window

Items	Detail Items	Description
Service status information	XGT server	Total No. of the frames communicated with XGT server service
	High speed link	Total No. of the frames communicated with high speed link service
	P2P	Total No. of the frames communicated with P2P service P2P
	Others	Total No. of the frames communicated with other services
Media status information (packets/sec)	Broadcast	Packets/sec of the frames communicated by broadcasting
	Multi-cast	Packets/sec of the frames communicated by multi-casting
	Unicast	Packets/sec of the frames communicated by uni-casting
	Group transmission	Packets/sec of the frames communicated by group transmission
Packet monitoring (packets/sec)	Packet sent	Packets/sec of the frames transmitted from each port
	Packet received	Packets/sec of the frames received by each port
	Relay packet	Packets/sec of the frames relayed by each port
	Error packet	Packets/sec of the errors occurred during the communication at each port

10.4.2 View error details

The detail information on the errors in the frames which are transmitted from or received by RAPIEnet I/F Modules can be viewed.

In the contents of the packet monitoring in the media information window, if the error count is 1 or more, the View Error Detail button on the bottom window is activated. Click this button to open the Detail Packet Monitoring window. In this window, number of the error packets for each port and each error can be checked.

Items	Description
Tx_Retry_Over Cnt	No. of the frames failed to be transmitted by 16 times of transmission
Delay Collision Detect Cnt	No. of the delay conflicts occurred in the line after transmission
Lost Carrier Cnt	No. of carrier lost occurred in the transmission
Carrier Not Detected Cnt	No. of failures to detect carrier during preamble transmission
CRC Error Frame Receive Cnt	No. of frame occurrence for which CRC error was received
Frame Receive Error Cnt	No. of frames where reception error occurred
Too-Short Frame Cnt	No. of received frames less than 64 bytes
Too-Long Frame Cnt	No. of received frames larger than 1518 bytes
Residual-Bit Frame Cnt	No. of received frames including Residual-Bit
Multicast Addr Frame Receive Cnt	No. of received frames having multi-cast addresses

10.5 Troubleshooting

This chapter is to describe defects and errors that may occur in system operation, their causes and actions to take against. If any error occurs on FDEnet I/F Module, its related details can be checked through the procedures below. Surely follow the troubleshooting procedures in the sequence as specified to check for abnormal Module state. And any discretionary repair or disassembly is not allowed.

10.5.1 Diagnosis through communication Module LED

The status of communication Module can be checked for defects on the Module through LED display.

(1) Display of abnormal operation

Diagnosis is available through LED in front of XGL RAPIenet Module.

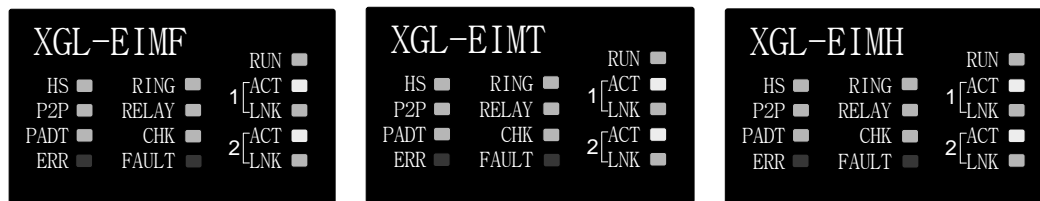

[Fig. 10.5.1] RAPIenet I/F MODULE LED

LED	Error Details	Action
RUN	Off after Module powered on	1) Installation error of EDMT I/F communication Module - Check for errors on power Module's DC 5V power supply. - Check if communication Module is installed correctly on the base. 2) Contact Customer Service center.
HS	Off during HS link service	1) Check if HS link setting is correct. 2) Check if link enable is On.
P2P	Off during command service	1) Check if the command is input correctly. 2) Check if connection is normal. 3) Check if the menu 'Enable Link' is On.
PADT	Off during remote connection service	1) Check if the station No. is correct for remote (PADT) connection. 2) Check if PADT program's remote connection is released.
RING	Off after ring configuration	1) Check if the connection and configuration is normal.
RELAY	Off during normal communication	1) Check if it is Ring master 2) Check if 2 ports are normal 3) Check if HS link, P2P setting and Enable Link are normal
ACT	Off during normal communication	1) Check TRX parameter 2) Check if connection is normal
LNK	Off during normal communication	1) Check if cable is connected 2) Check status of partner
CHK	On during normal communication	1) Check if there is duplicated station number
FAULT	On during normal communication	1) Check if there is duplicated station number among partner connected to 2 ports
ERR	On during normal communication	1) PLC reset 2) Power on/off 3) Contact custom service center

Chapter 10 Diagnostic Function

Diagnosis is available through LED in front of XGL ES4T Module.

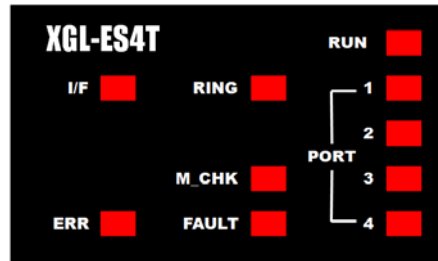

[Fig 10.5.2] MRS I/F Module LED

LED	Error Details	Action
RUN	Off after Module powered on	1) Check the base status 2) LED operation Check 3) Contact custom service center.
I/F	On or Off	1) Reapplied Power off/on 2) LED operation Check 3) Contact custom service center
ERR	Flicker	1) Check if there is duplicated station number
RING	Flicker	1) Check Ring network topology (Diagnosis -> Autoscan)
M_CHK	On	1) Check if there is duplicated station number
FAULT	On	1) Check H/W operation 2) Contact custom service center
CHK x	On	1) Check cable 2) Check the input noise 3) Check H/W operation

10.5.2 Diagnosis of Communication Module through XG5000

XG5000 program can be used to monitor the communication Module simply to check for any error thereon. Connect RS-232C connector with CPU port and then select [Online] → [Diagnosis] → [PLC History] in XG5000.

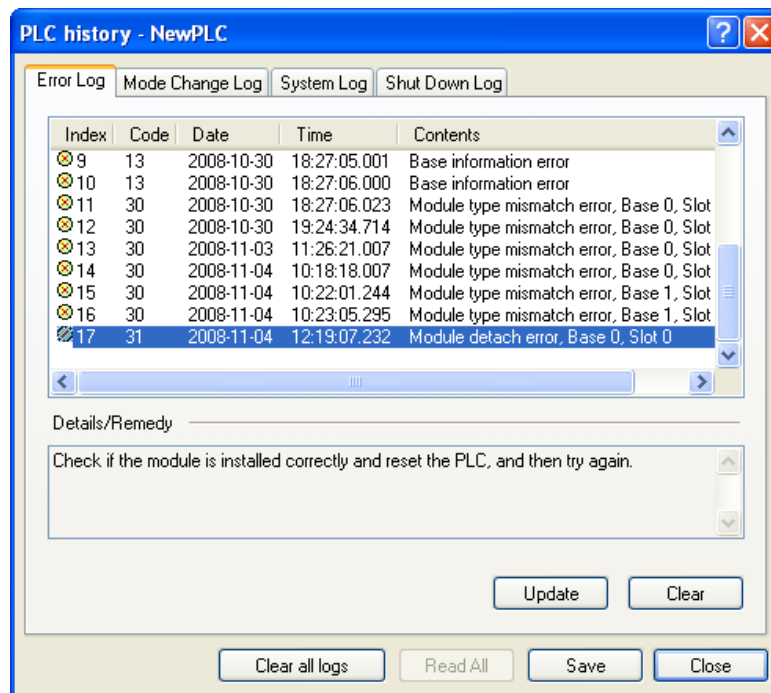

[Fig. 10.5.2] PLC history detail information monitor

If a hardware error or a CPU interface error occurs on the Module, LED of the communication Module itself operates abnormally in general, whose status can be monitored simply through its dedicated program.

[Fig. 10.6.2] shows error/warning information through PLC History on the XG5000 [Online] menu, which can be resolved by referring to "Details/Remedy".

10.5.3 Checking module healthiness with system log

Healthiness of communication modules can be roughly checked with XG5000 software. Connect CPU module via RS-232C or USB connector. In the [System Diagnosis] window of the XG5000, right-click the RAPIenet I/F module, and select [System Log] to open the log window.

(1) Memory area log

Error occurrence and service provision can be checked.

[Fig. 10.6.3] shows the memory area log of the System Log.

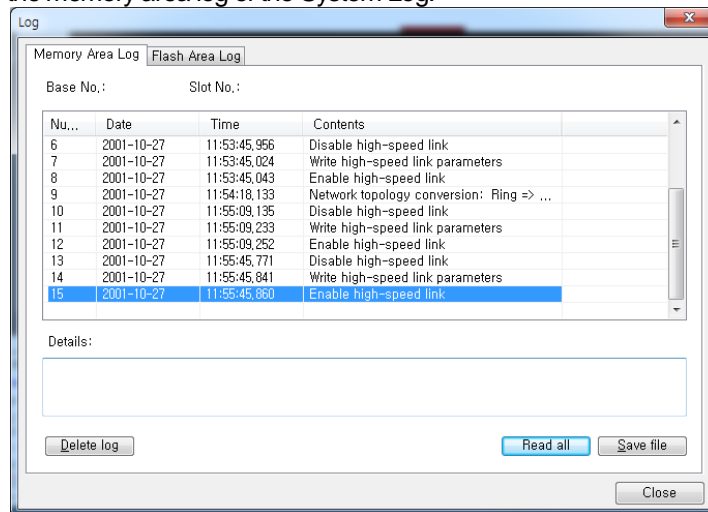

[Fig. 10.5.3] Memory area log of System Log

Time and description of the events such as error or service provision can be viewed.

(2) Flash area log

When error or service provision cannot be checked with XG5000, or to save the content of the current memory area in flash, press the log switch on the front of the RAPIenet I/F module. The memory area log will be saved in the flash automatically.

[Fig. 10.5.4] shows the flash area log of System Log.

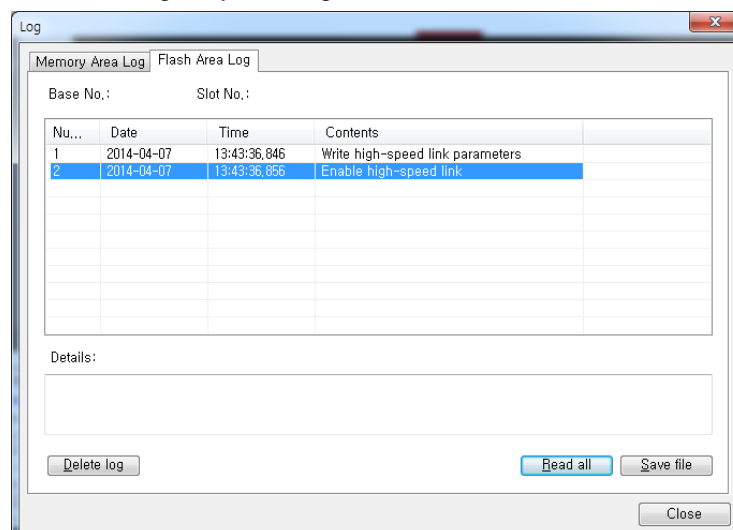

[Fig. 10.5.4] Flash area log of System Log

Chapter 11 System Configuration of RAPIEnet PC Card

11.1 Installation and Execution of Software

Software RAPIEnet-PD needs to meet the following system requirements for execution.

- (1) PC and Memory
A computer with memory of more than 128MB or CPU of more than Pentium is needed.
- (2) Communication port
RS-232C serial port or USB port is needed.
- (3) Hard Disc
Available area of more than minimum 10MB is needed.
- (4) Mouse
A mouse connectable with the computer is needed.
- (5) monitor
Resolution shall be higher than 1024 X 768.
- (6) Windows
It is available to be executed on Windows 2000/XP. But, on Windows 98/ME, XG5000 may be down if several applications are executed including other products due to memory limitation. Use them on Windows 2000 or XP.

11.1.1 Installation of RAPIEnet-PD

- (1) Install installation file.
- (2) Installation wizard prepares for installation as following.



[Figure 11.1.1] Installation Screen of RAPIEnet-PD

- (3) RAPIEnet-PD designates a folder to be installed. If you want to change folders, click on the Search button to input or select a new folder. Since RAPIEnet-PD needs installation space of about 30MB, select a disc that has sufficient space. If installation space is not sufficient, warning message will appear and moving to the next step will be impossible.
- (4) If setting a folder, press the Next button.

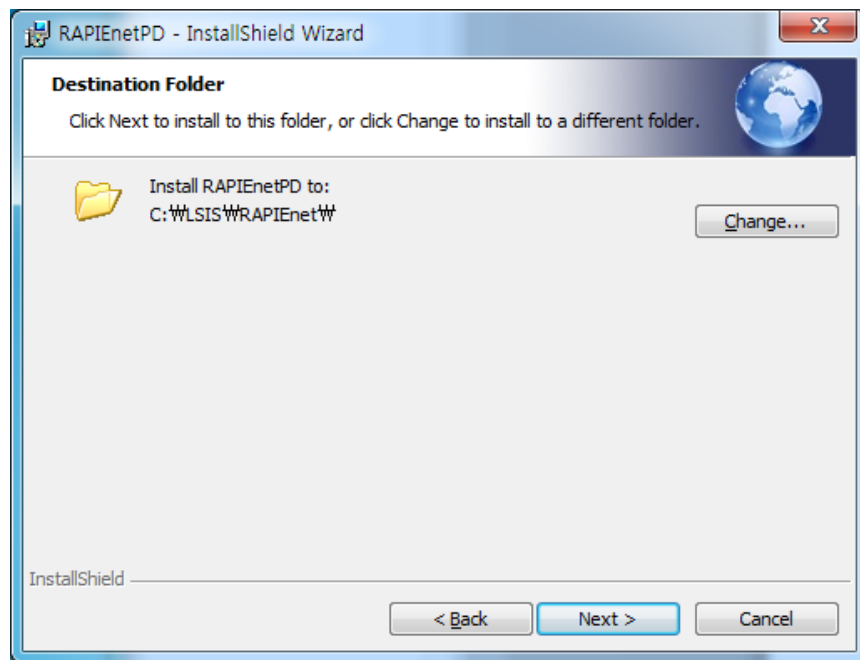

[Figure 11.1.2] Setting Screen of RAPIenet-PD

(5) Check installation path and press the Next button. Installation is starting as following.

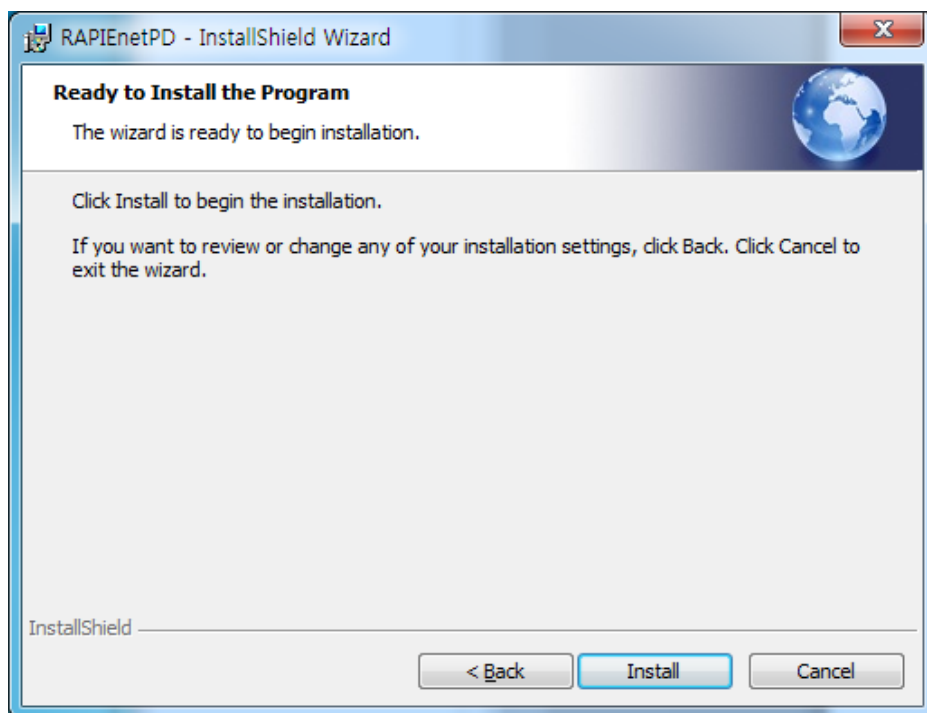

[Figure 11.1.3] Screen to Show Completion of Preparation for installing RAPIenet-PD

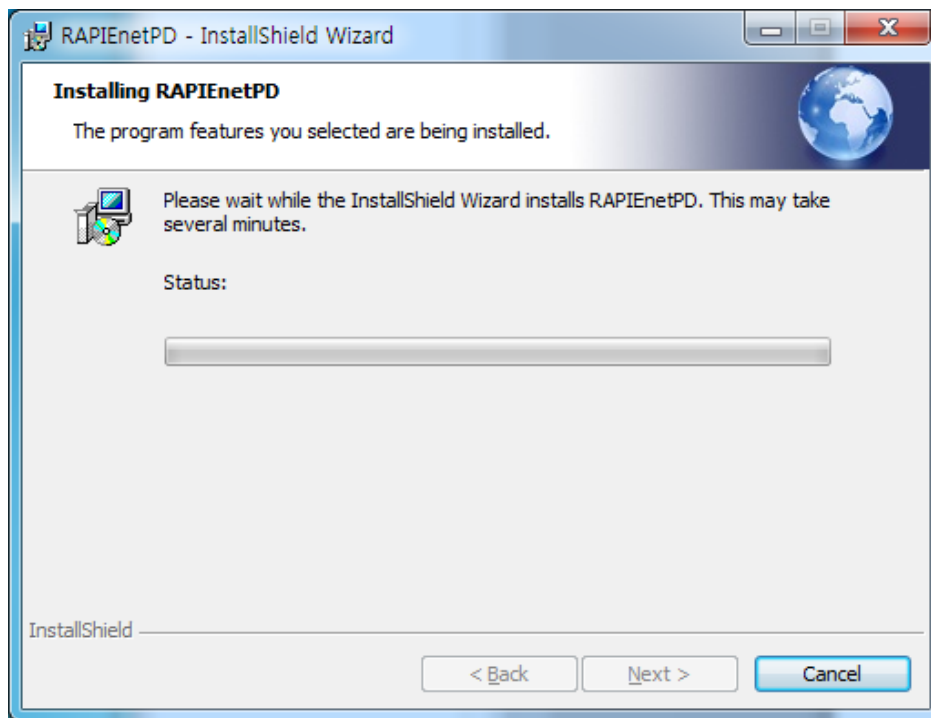

[Figure 11.1.4] Screen to Show Installation Progress of RAPIenet-PD

(6) RAPIenet driver, RAPIenet device install screen appears in the middle of installation as following.

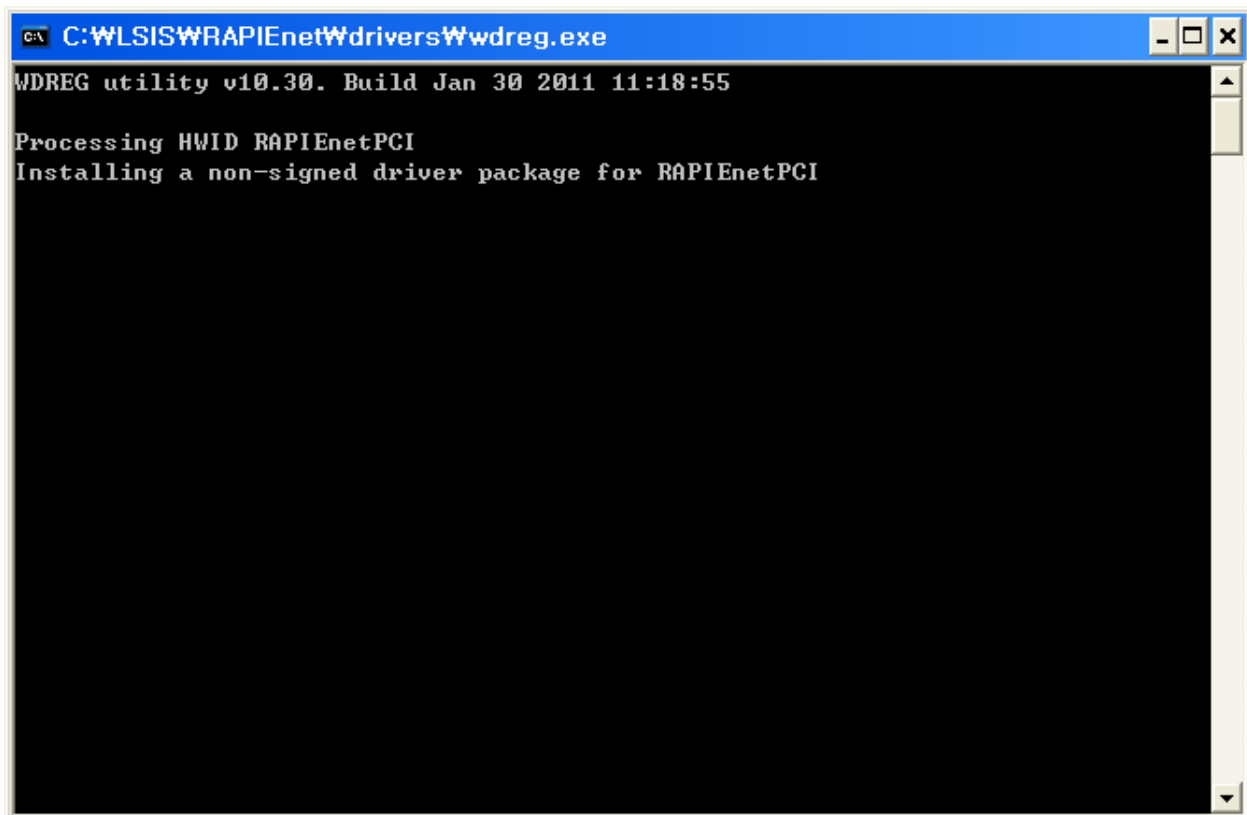

[Figure 11.1.5] Installation Screen of RAPIenet PC Card Driver

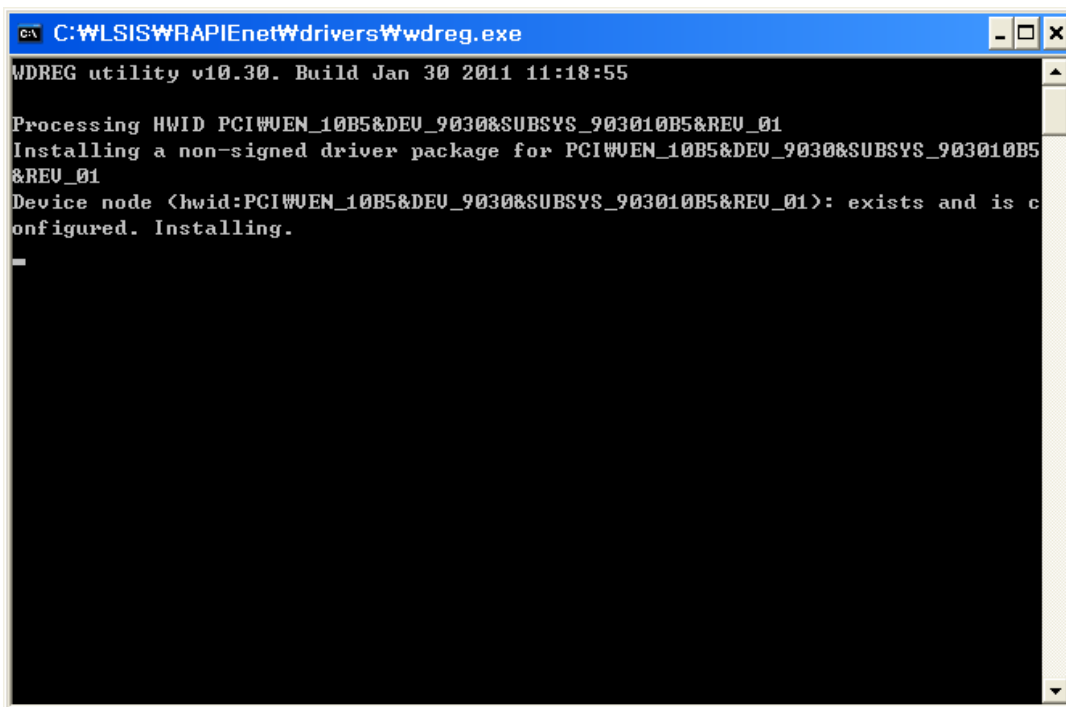

[Figure 11.1.6] Installation Screen of RAPIEnet PC Card Device



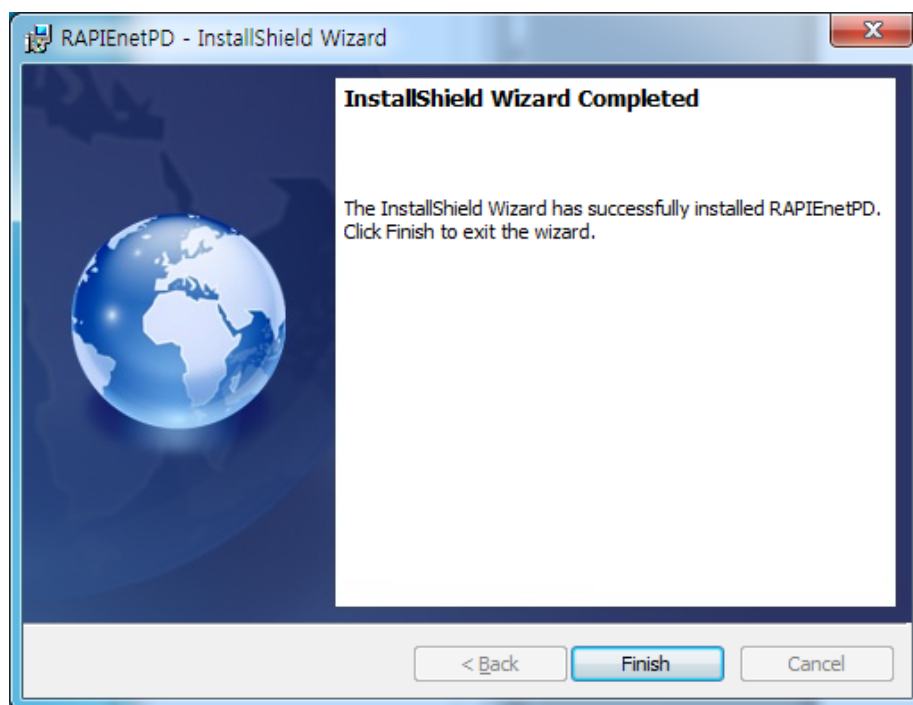







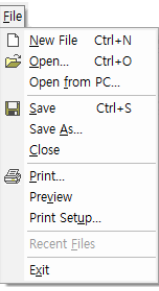



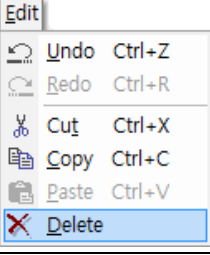





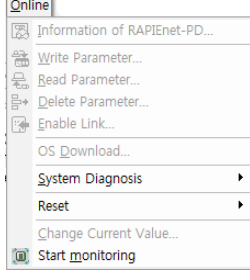

(7) After waiting for a while, installation is completed as following.



[Figure 11.1.7] Screen to Show Completion of RAPIEnet PC Card Installation

11.1.2 Menu Information of RAPIEnet-PD

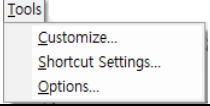
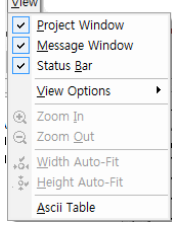
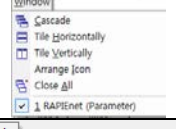
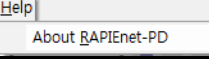
The relationship between menu bar and shortcut icons of RAPIEnet-PD is as following.

Menu Bar	Menu	Icon	Description	
	New File		A new file is created	
	Open		One of saved files is opened	
	Open From PLC	-	A saved file is imported from PLC	
	Save		A file is saved	
	Save as	-	A file is saved in a different name	
	Print		A designated portion is printed	
	Print Preview	-	Contents to be printed are displayed in advance	
	Project Print	-	Setting parameters are printed	
	Set Printer	-	A printer and printing direction are set	
		Undo		It returns to previous status of the current one.
		Re-execute		When setting parameters, it returns to the original status once again after executing "Undo"
Cut			When removing written contents and pasting them in other place.	
Copy			Copied	
Paste			Copied contents are pasted	
Delete			Deleted	
		RAPIEnet Registration Information		When importing registration Information of RAPIEnet PC Card
	Write Parameter		When writing parameter contents edited on RAPIEnet-PD	
	Read Parameter		When reading parameters saved on RAPIEnet-PD	
	Delete Parameter		When deleting parameters saved on RAPIEnet-PD	
	Link Enable		When allowing communication to a communication module set as high-speed link or P2P	
	OS Download	-	Download RAPIEnet PC Card OS	
	Reset	All Board Reset		Reset all of RAPIEnet PC Cards
		Individual Reset		Reset relevant RAPIEnet PC Cards only
		Reset Log		When checking reset log
	Change Current Value	-	When changing values for the selected memory	
	Start Monitoring		When starting monitoring of the device monitor	
	User Definition	-	User's selection/cancellation of menu related to tools	
	Set Shortcut Key	-	Set/cancel shortcut key for each menu	
	Project Option	-	Application/Cancelling of options related to projects	
		Project Window	-	Tool bar is activated on RAPIEnet-PD
Message Window		-	The message window is activated	
Module Information Window		-	It displays whether the online system diagnosis window is activated or not.	
Status Display Line		-	When displaying status display line	
Used Device		-	Device area used for parameters	
ASCII Table		-	When reporting ASCII and hexadecimal values	
		Cascade	-	Windows are arranged in cascades
		Check pattern	-	Windows are arranged in check pattern
	Icon Arrangement-	-	Not used.	
	RAPIEnet-PD Information		When checking RAPIEnet-PD version information	

[Table 11.1.1] RAPIEnet-PD Menu Information Screen

11.2 Basic Settings of RAPIEnet-PD

11.2.1 Basic Settings

Before using RAPIEnet-PD, you need to know the following basic items.

- (1) Set connection of the installed RAPIEnet PC Card
Set connection with RAPIEnet PC Card through 'File' → 'OPEN FROM PC'

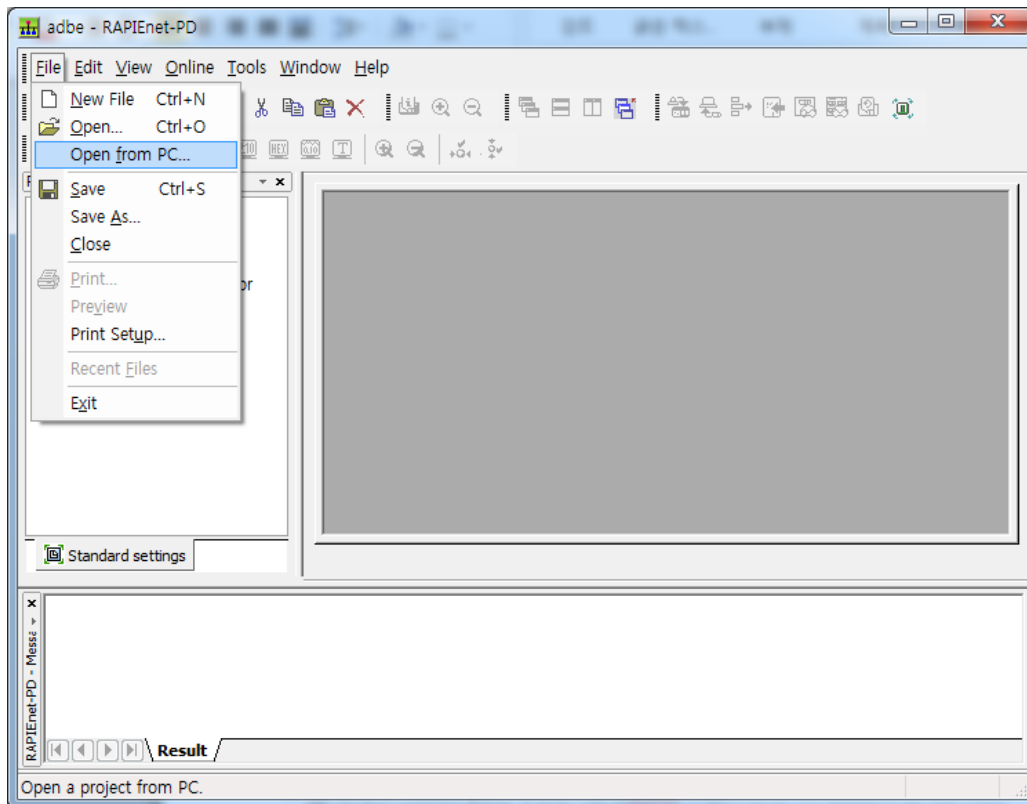

[Figure 11.2.1] Screen to Set Connection with RAPIEnet PC Card

- (2) Check registration Information of the connected RAPIEnet PC Card
Select RAPIEnet PC Card you want to check its registration information and then click on 'Online' → 'RAPIEnet Registration Information' or click the right button of the mouse on RAPIEnet PC Card existing on the project window to select 'RAPIEnet Registration Information'.
- (3) Registration Information
You may check basic information (link kind, action mode, high-speed link), link information (station number, kind, MAC Address), SW, HW information (HW version, HW status, SW version, SW date) and other relevant information.
- (4) Parameter Setting
Double click on Parameter on the project window to import the parameter setting window. You may set high-speed link parameters on the parameter setting window and if so, high-speed link will act based on the set parameters here.

Index	Mode	Station number	Block number	Read area Word size	Save area Word size	Read area Word position	Write area Word position
0							
1							
2							
3							
4							
5							
6							
7							

[Figure 11.2.2] Parameters Setting Window Screen of RAPIEnet PC Card

(5) Device Monitor

Double click on Device Monitor on the project window to import the device monitor window. You may check the memory of device monitor RAPIEnet PC Card on the device monitor window. To check how it actually changes, select 'Online' →

'Start Monitoring' or click on  among shortcut icons

	0	1	2	3	4	5	6	7	8	9
M0000	0000	0000	0000	0000	0000	0000	0000	0000	0000	0000
M0010	0000	0000	0000	0000	0000	0000	0000	0000	0000	0000
M0020	0000	0000	0000	0000	0000	0000	0000	0000	0000	0000
M0030	0000	0000	0000	0000	0000	0000	0000	0000	0000	0000
M0040	0000	0000	0000	0000	0000	0000	0000	0000	0000	0000
M0050	0000	0000	0000	0000	0000	0000	0000	0000	0000	0000
M0060	0000	0000	0000	0000	0000	0000	0000	0000	0000	0000
M0070	0000	0000	0000	0000	0000	0000	0000	0000	0000	0000
M0080	0000	0000	0000	0000	0000	0000	0000	0000	0000	0000
M0090	0000	0000	0000	0000	0000	0000	0000	0000	0000	0000
M0100	0000	0000	0000	0000	0000	0000	0000	0000	0000	0000
M0110	0000	0000	0000	0000	0000	0000	0000	0000	0000	0000
M0120	0000	0000	0000	0000	0000	0000	0000	0000	0000	0000
M0130	0000	0000	0000	0000	0000	0000	0000	0000	0000	0000
M0140	0000	0000	0000	0000	0000	0000	0000	0000	0000	0000

[Figure 11.2.3] Device Monitor Screen of RAPIEnet PC Card

Chapter 12 High-Speed Link of RAPIEnet PC Card

It is possible to use high-speed link services provided on RAPIEnet PC Card by realizing directly through RAPIEnet-PD Tools and Lib. This chapter describes how to use high-speed link services through RAPIEnet-PD.

12.1 Introduction

High-speed link is a communication method between RAPIEnet PC Cards and between RAPIEnet PC Card and PLC and sending/receiving data can be possible by setting high-speed link parameters and furthermore, this data transmission service allows the user to set the size of sending/receiving data, sending/receiving interval, sending/receiving area and saving area by using RAPIEnet-PD for data exchange. But, since this high-speed link service use Subnet Broad service, it may have effect on other communication modules that use the same network.

High-speed link functions are as following:

- (1) Enable to set a high-speed link block
 - A. If there are several sending/receiving areas, it is possible to set maximum 64 blocks for sending and maximum 64 blocks for receiving so total up to 128 blocks can be set.
 - B. Up to 200 words per block can be set.
- (2) Enable to set a sending/receiving interval
Since the user can set a sending/receiving interval, a sending/receiving interval from 5ms to 1s can be set.
- (3) Enable to set a sending/receiving area
A sending/receiving area for each data block can be set according to the set I/O address.

12.2 Driving Sequence by High-Speed Link

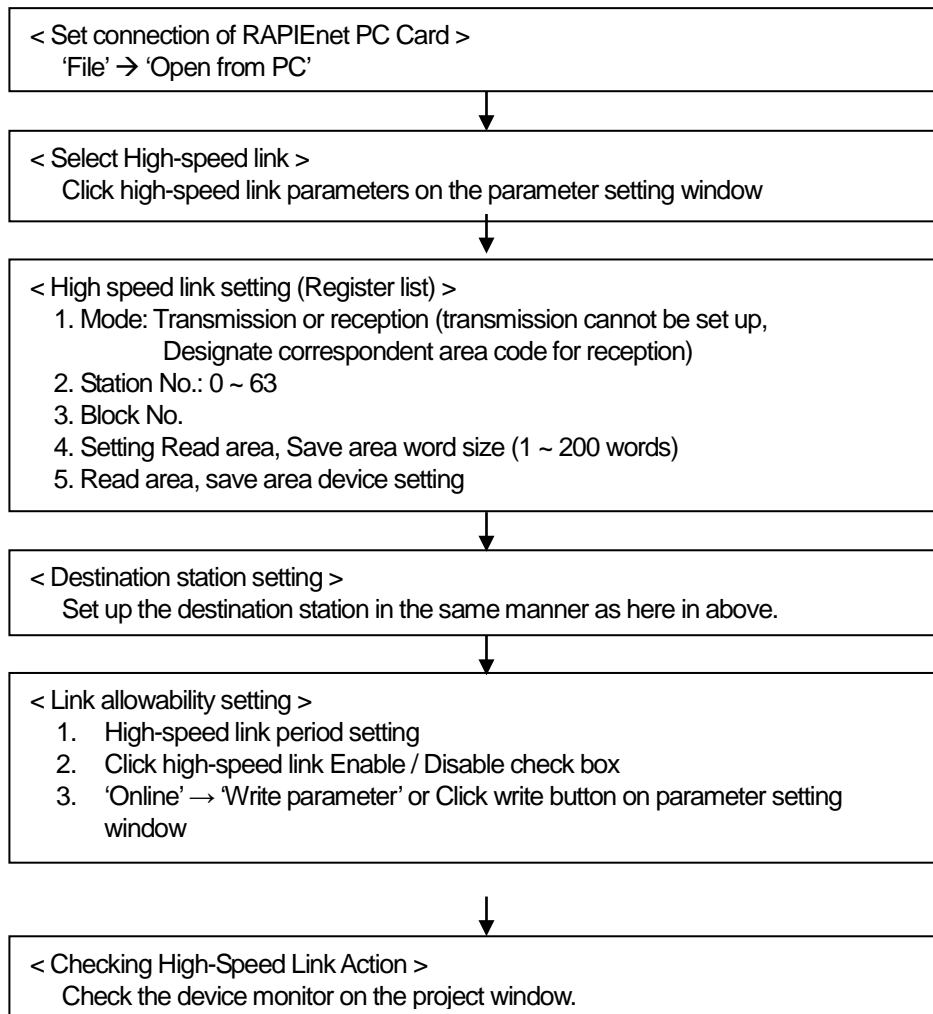

12.3 Setting High-Speed Link Parameter

- (1) Execute RAPIEnet-PD
 Click on Window 'Start' → 'All Program' → 'LSIS' → 'RAPIEnet-PD' → 'RAPIEnet-PD' icon.
 If RAPIEnet PC Card is already installed, click on 'File' → 'Open from PC' and if not, click on 'File' → 'New File' to create a project.
- (2) Parameter Setting of High-Speed Link
 - A. Setting Initial Screen of High-Speed Link Parameter
 If the user double clicks on applicable RAPIEnet PC Card parameter on the project window, the parameter setting Window will be displayed.

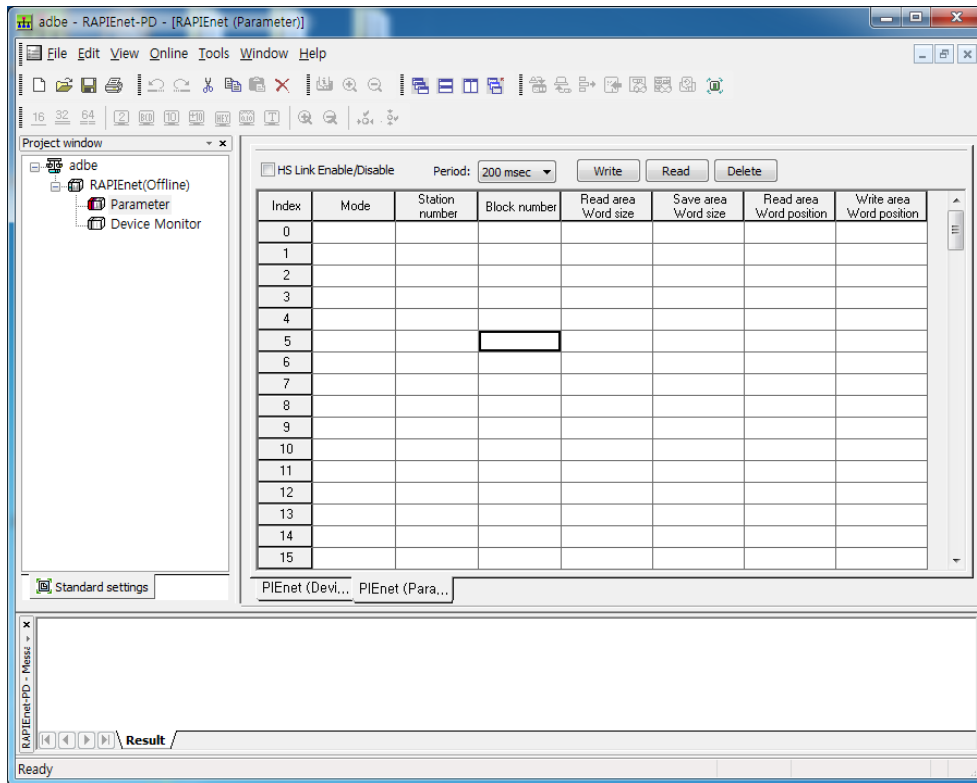

[Figure 12.3.1] Parameter Setting Screen of High-Speed Link

- B. Block Setting of High-Speed Link
 A screen for setting a high-speed link block is as seen in [Figure 12.3.2]. Each item has the meanings in [Table 12.3.1].

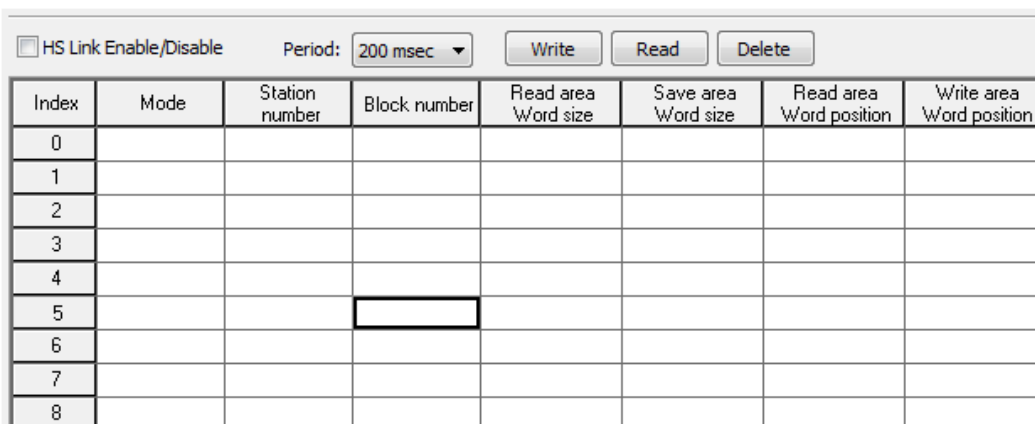

[Figure 12.3.2] Block Setting Screen of High-Speed Link

Classification		Description
Mode	Send	Send data
	Receive	Receive data
Station Number	Counterpart Station Number	Only receiving can be set, Sending cannot be set. Setting Range : 0 ~ 63
Block Number	Block Number	Set a sending/receiving block Sending block : Maximum 64 blocks(Setting Range : 0 ~ 63) → The same block number cannot be set. Receiving block : Maximum 128 blocks(Setting Range : 0 ~ 63) → Same station number: The same block number cannot be set. → Different station number: The same block number can be set.
Word Size of Area to Read	Size(Word)	Designate the size of data to send Setting Unit : Word Setting Range :1 ~ 200
Word Size of Area to Save	Size(Word)	Designate the size of data to receive Setting Unit : Word Setting Range :1 ~ 200
Word Location of Area to Read	Offset	Area that designates the starting location to memory the device used when sending - 0 ~ 25599 memory areas are available - Areas to read (Word Size + Word Location) shall not exceed 25600 Cautious not to overlap with the device address being used in the program
Word Location of Area to Save	Offset	Area that designates the starting location to memory the device used when receiving - 0 ~ 25599 memory areas are available - Areas to sav (Word Size + Word Location) shall not exceed 25600 Cautious not to overlap with the device address being used in the program

[Table 12.3.1] High-Speed Link Item

C. Additional Description on High-Speed Link Parameters

As seen in [Figure 12.3.3], Offset means the starting point of memory and Size refers to the actual size of sending/receiving data. Therefore, the area from Offset value to Offset + Size value is an area to assign memory. Whatever the address number of memory with data on Module 1 or Module 2 is, set Offset on the memory you want to save on RAPIenet PC Card to save the memory while the set offset serves as the starting address number. Therefore, the user may save any data he/she wants in the area.

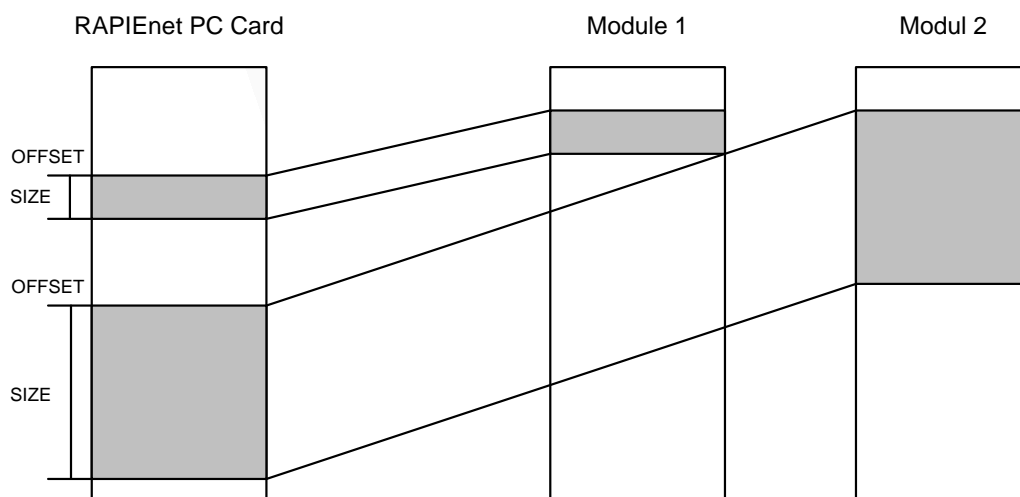

[Figure 12.3.3] Relationship between Offset and Size

(3) Read High-Speed Link Parameter

It is used when importing parameter information that has been set on RAPIenet PC Card.

After selecting a module you want to read parameter information from RAPIenet-PD's 'Online' → 'Read Parameter' window, click on the Confirm button or click on 'Read Parameter' icon () to read parameter information.

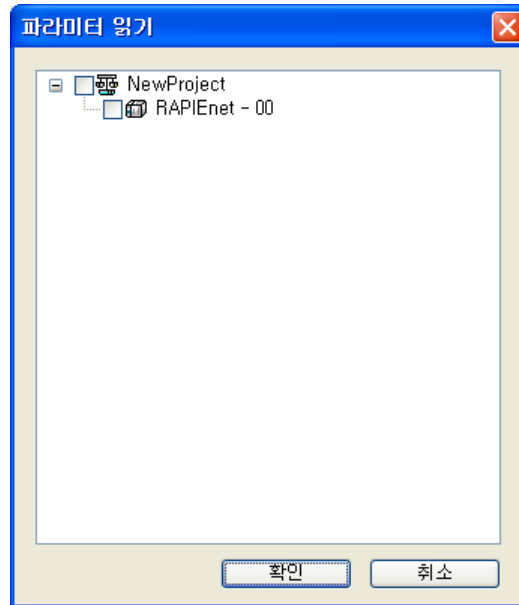

[Figure 12.3.4] Read High-Speed Link Parameter

(4) Write High-Speed Link Parameter

It is used when downloading a value that has been set on the parameter setting window to RAPIenet PC Card.

After selecting a module you want to write parameter from RAPIenet-PD's 'Online' → 'Write Parameter' window, click on the Confirm button or click on 'Write Parameter' icon () to write parameter information.

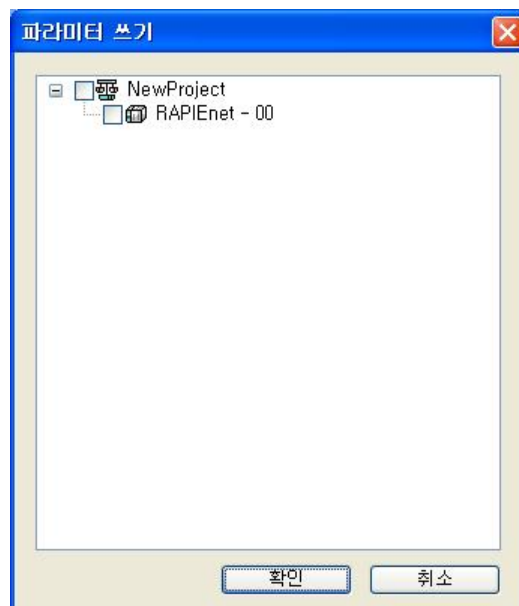

[Figure 12.3.5] Write High-Speed Link Parameter

(5) Delete High-Speed Link Parameter

Any parameter information that has been set on RAPIenet PC Card can be deleted.

After selecting a module you want to delete a parameter from RAPIenet-PD's 'Online' → 'Delete Parameter' window, click on the Confirm button or click on 'Delete Parameter' icon () to delete the parameter information.

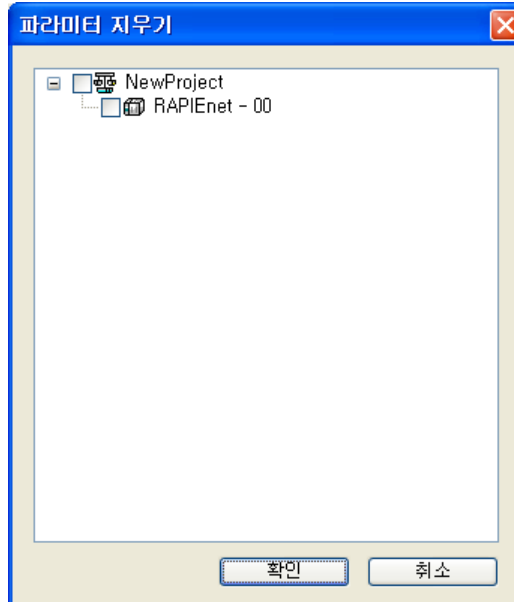

[Figure 12.3.6] Delete High-Speed Link Parameter

(6) Set High-Speed Link

RAPIenet PC Card' high-speed link can be set only after 'Enable / Disable' is set.

After selecting a module you want to set a link with from RAPIenet-PD's 'Online' → 'Link Enable' window, click on the Confirm button or click on 'Link Enable' icon () to set high-speed link.

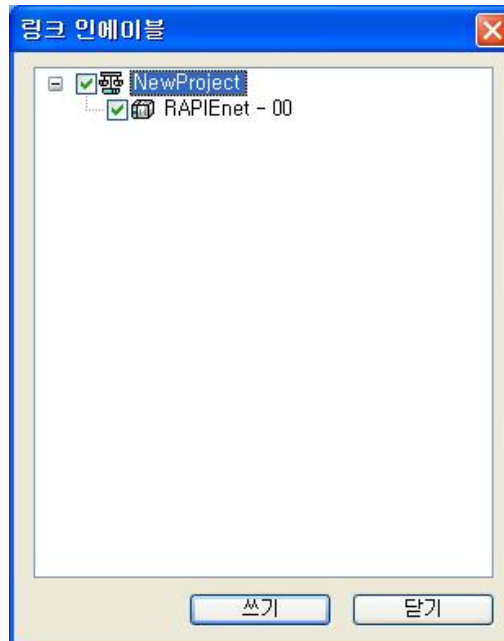

[Figure 12.3.7] Enable High-Speed Link

12.4 Checking High-Speed Link Action

For high-speed link action, set parameters on RAPIEnet PC Card and then implement 'Link Enable' process. In addition, to verify its action directly and visually, it is possible through the device monitor or the module that conducts diagnosis function and high-speed link communication.

12.4.1 Example of Setting Parameter

Setting parameters is available on the project window on the right side of RAPIEnet-PD. [Figure 12.4.1] shows examples of setting parameters. The user may configure sending/receiving in a form as seen below referring to the parameter setting details. If 'Link Enable process' does not get through once after setting is completed, high-speed link service will not run. Make sure to check 'Link Enable'

Index	Mode	Station number	Block number	Read area Word size	Save area Word size	Read area Word position	Write area Word position
0	Send		0	200		0	
1	Receive	2	0		150		500
2	Send		1	100		200	
3	Receive	3	0		50		650
4	Send		2	50		300	
5	Receive	2	1		100		700
6	Send		3	150		350	
7	Receive	3	1		200		800

[Figure 12.4.1] Write High-Speed Link Parameter

12.4.2 Device Monitor

If high-speed link normally runs after setting parameters is completed, you may see RAPIEnet PC Card' LED is flashing. To see actual changes in data, check the device monitor on the project window. If you click on the device monitor, a window as seen in [Figure 12.4.2] will appear. If you do not click on 'Monitor Start' here, monitoring will not proceed. Make sure to click on 'Monitor Start'(Once monitoring starts, the address number of each memory is displayed in blue.)

	0	1	2	3	4	5	6	7	8	9
M0000	0000	0000	0000	0000	0000	0000	0000	0000	0000	0000
M0010	0000	0000	0000	0000	0000	0000	0000	0000	0000	0000
M0020	0000	0000	0000	0000	0000	0000	0000	0000	0000	0000
M0030	0000	0000	0000	0000	0000	0000	0000	0000	0000	0000
M0040	0000	0000	0000	0000	0000	0000	0000	0000	0000	0000
M0050	0000	0000	0000	0000	0000	0000	0000	0000	0000	0000
M0060	0000	0000	0000	0000	0000	0000	0000	0000	0000	0000
M0070	0000	0000	0000	0000	0000	0000	0000	0000	0000	0000
M0080	0000	0000	0000	0000	0000	0000	0000	0000	0000	0000
M0090	0000	0000	0000	0000	0000	0000	0000	0000	0000	0000
M0100	0000	0000	0000	0000	0000	0000	0000	0000	0000	0000
M0110	0000	0000	0000	0000	0000	0000	0000	0000	0000	0000
M0120	0000	0000	0000	0000	0000	0000	0000	0000	0000	0000
M0130	0000	0000	0000	0000	0000	0000	0000	0000	0000	0000
M0140	0000	0000	0000	0000	0000	0000	0000	0000	0000	0000

Refer to the offset and size the user has set on the parameter setting window to compare.

12.4.3 Comparison between Communication Modules

Compare and analyze while checking the memory of nodes connected with RAPIEnet PC Card and the set parameters. In case that sending is set on RAPIEnet PC Card, check whether the value of the address number of the set memory on the parameter setting window is normally delivered. In case of receiving, check whether the delivered value from the module connected with RAPIEnet PC Card is normally received and displayed on the memory. For details on RAPIEnet Module, refer to 'Chapter 5 Communication Parameter', 'Chapter6 High-Speed Link'and 'Chapter7 P2P Service.'

12.4.4 Diagnosis function

See'Online' → 'System Diagnosis' → 'Media Information,' to check the amount of packets sent/received to/from RAPIEnet PC Card. For details, refer to 'Chapter 15 Diagnosis Function of RAPIEnet PC Card.'

Chapter 13 Program Realization of RAPIEnet PC Card

RAPIEnet PC Card provides general users with RAPIEnet-PD application tools and advanced users with Lib. Through Lib, users can add only necessary functions of RAPIEnet PC Card for them to use. This chapter describes how to realize a program by using Lib for advanced users.

13.1 Introduction

High-speed link and P2P Service can be used by using Lib provided by RAPIEnet PC Card. When using RAPIEnet-PD Tools, the user can use high-speed link but he/she cannot use P2P Service. Therefore, the user has to realize a program by him/herself to use P2P Service. This chapter describes how to use high-speed link and P2P Service by realizing a program. Since example programs are included if RAPIEnet-PD is installed, refer those example programs when realizing a program (see 'Chapter 14 Example Program')

13.1.1 Realization Sequence of High-Speed Link

- (1) Install RAPIEnet-PD
- (2) Register COM Interface
- (3) Realize high-speed link by using Lib function provided by RAPIEnet PC Card.
COM Interface registration methods, function usage methods and variable types may vary depending on the user's tools.

13.1.2 Realization Sequence of P2P Service

- (1) Install RAPIEnet-PD
- (2) Register COM Interface
- (3) Realize P2P Service by using Lib function provided by RAPIEnet PC Card.
COM Interface registration methods, function usage methods and variable types may vary depending on the user's tools.

13.2 Program Realization Method

13.2.1 COM Interface Registration Method

- (1) C++ Environment
 - A. COM Interface Registration

```

00001 #include "stdafx.h"
00002 #import "C:/LSIS/RAPIEnet/RAPIEnetService.exe" no_namespace
00003
00004 IRAPIEnetInterface* pIRAPIEnetInterface;
00005 const IID IID_IRAPIEnetInterface = {0x558F1700, 0x4030, 0x4B51, {0x99, 0xB7, 0x35, 0x66, 0x28, 0xAD, 0x29, 0x
65}};
00006
00007 BOOL InitCOMInterface()
00008 {
00009     HRESULT hr;
00010     CLSID clsid;
00011     ::CoInitializeEx(NULL, COINIT_APARTMENTTHREADED);
00012     hr = ::CLSIDFromProgID(L"RAPIEnetService.RAPIEnetInterface.1", &clsid);
00013     if (hr != S_OK) {
00014         AfxMessageBox("레지스트리에 등록되지 않았습니다!");
00015         return FALSE;
00016     }
00017     IUnknown* pUnk = NULL;
00018     hr = ::CoCreateInstance(clsid, NULL, CLSCTX_ALL,
00019         IID_IUnknown, (void**)&pUnk);
00020     if (hr != S_OK) {
00021         AfxMessageBox("인스턴스를 생성할 수 없습니다!");
00022         return FALSE;
00023     }
00024     hr = pUnk->QueryInterface(IID_IRAPIEnetInterface, (void**)&pIRAPIEnetInterface);
00025     if (hr != S_OK) {
00026         AfxMessageBox("IRAPIEnetInterface 인터페이스를 구할 수 없습니다!");
00027         return FALSE;
00028     }
00029     pUnk->Release();
00030     return TRUE;
00031 }
00032
00033 void ExitCOMInterface()
00034 {
00035     pIRAPIEnetInterface->Release();
00036     ::CoUninitialize();
00037 }
00038
00039 IRAPIEnetInterface* GetCOMInterface()
00040 {
00041     return pIRAPIEnetInterface;
00042 }

```

[Figure 13.2.1] COM Interface Registration File

To register COM Interface, add ComFunction.cpp file that contains contents as seen in [Figure 13.2.1].

- Input the path that installs RAPIEnet-PD for the blank appeared after #import

- B. COM Interface Declaration

If the user adds the following declaration phrase at the starting part of the source to be realized, COM interface will be declared.

```
#import "C:\Install Path\RAPIEnetService.exe" no_namespace
Extern IRAPIEnetInterface* GetCOMInterface();
```

- To run it normally, perform COM interface declaration only after adding ComFunction.cpp.

(2) C# Environment

A. COM Interface Registration

If the user clicks on 'Project' → 'Add Reference,' a window to add a reference will appear.

If the user selects RAPIEnetService 1.0 Type Library from COM tab here, he/she may register COM Interface.

B. COM Interface Declaration

If the user adds the following declaration phrase at the starting part of the source to be realized, COM interface will be declared.

```
RAPIEnetServiceLib.IRAPIEnetInterface m_RAPIEnetInterface;
Public RAPIEnetServiceLib.IRAPIEnetInterface RAPIEnetInterface
{
    get { return m_RAPIEnetInterface;    }
}
```

```
RAPIEnetServiceLib.IRAPIEnetInterface m_RAPIEnetInterfaceClass
= new RAPIEnetServiceLib.RAPIEnetInterfaceClass();
m_RAPIEnetInterface = (RAPIEnetServiceLib.IRAPIEnetInterface) m_RAPIEnetInterfaceClass;
```

13.2.2 User Function

Since how to use functions may vary depending on the user's tools so that the user has to consider this when realizing the program.

The same function names are used in C++, C#. This chapter describes basic functions only related to setting connection with RAPIEnet PC Card, sending and receiving. For information on other functions, see Attachment.

Function Name	Description	Return Value	Parameter
InitDevice	Set connection with RAPIEnet PC Card	Accept/Reject	process Instance
			Mounted RAPIEnet PC Card Handle t
			The number of mounted RAPIEnet PC Card
ReadDevice	Read and save the designed area of the counterpart's station	Accept/Reject	Currently selected RAPIEnet PC Card Handle
			Information on station number (high-speed link is ignored)
			device information (high-speed link : HS, P2P : M, D ...)
WriteDevice	Save the data of My station's designed area in the counterpart station's defined area	Accept/Reject	Offset information (The starting point of memory to Read and Write)
			Size (Size of data that Read and Write)
			Saving buffer

[Table 13.2.1] Basic Function of RAPIEnet PC Card

(1) C++ Environment

A. High-Speed Link

```
DWORD dwProcessId = GetCurrentProcessId();
```

- Part that receives ID of the current process.
- It is a necessary part to enable to call several programs related to RAPIEnet PC Card.

```
int hCard[16], nInstalledCardNo;
```

- It is a necessary part to bring the number of PC Card mounted to RAPIEnet PC Card's handle.

```
GetCOMInterface()->InitDevice(dwProcessId, hCard, &nInstalledCardNo);
```

- Function to set connection with RAPIEnet PC Card.
- If it is called only once at the beginning, any connecting and setting work is not needed until the program is ended.

```
UINT m_nStationNo, m_nOffset, m_nSize;  
CString strDevice;  
BYTE *buffer;
```

```
GetCOMInterface()->ReadDevice(hCard, m_nStationNo, strDevice, m_nOffset, m_nSize, buffer);
```

- hCard : RAPIEnet PC Card handle.
- m_nStationNo : Any station number is not used for high-speed link. (Set as 0)
- strDevice : It shall be set as 'HS' to use high-speed link.
- m_nOffset : The beginning location of data memory area to be received.
- m_nSize : The size of data to be received .
- buffer : The space in which data to be received are saved.

```
GetCOMInterface()->WriteDevice(hCard, m_nStationNo, strDevice, m_nOffset, m_nSize, buffer);
```

- hCard : RAPIEnet PC Card handle.
- m_nStationNo : Any station number is not used for high-speed link. (Set as 0)
- strDevice : It shall be set as 'HS' to use high-speed link.
- m_nOffset : The beginning location of data memory area to send.
- m_nSize : The size of data to send.
- buffer : The space in which data to send are saved.

Example 1) offset : 0, size : 200, Sending

```
GetCOMInterface()->WriteDevice(hCard, 0, 'HS', 0, 200);
```

Example 2) offset : 500, size : 150, Receiving

```
GetCOMInterface()->ReadDevice(hCard, 0, 'HS', 500, 150);
```

- For hCard, input the handle value to be brought from InitDevice.

B. P2P Service

GetCOMInterface()->InitDevice() Function is the same with that of high-speed link.

ReadDevice, WriteDevice variable type is the same with that of high-speed link.

```
GetCOMInterface()->ReadDevice(hCard, m_nStationNo, strDevice, m_nOffset, m_nSize, buffer);
```

- hCard : RAPIEnet PC Card handle.
- m_nStationNo : Set it the station number of RAPIEnet to be received.
- strDevice : Set appropriate to the memory type of the received module. (ex) M, D...)
- m_nOffset : The beginning location of data memory area to be received.
- m_nSize : The size of data to be received .
- buffer : The space in which data to be received are saved.

```
GetCOMInterface()->WriteDevice(hCard, m_nStationNo, strDevice, m_nOffset, m_nSize, buffer);
```

- hCard : RAPIEnet PC Card handle.
- m_nStationNo : Data to send shall be set the station number of the received RAPIEnet module .
- strDevice : Set the sent data appropriate to the memory type of the received module. (ex) M, D...)
- m_nOffset : The beginning location of data memory area to send.
- m_nSize : The size of data to send.
- buffer : The space in which data to send are saved.

Example 1) offset : 300, size : 50, Sending

```
GetCOMInterface()->WriteDevice(hCard, 2, 'M', 300, 50);
```

Example 2) offset : 700, size : 100, Receiving

```
GetCOMInterface()->ReadDevice(hCard, 2, 'M', 700, 100);
```

- For hCard, input the handle value to be brought from InitDevice.
- Select the memory type of the module that communicates application values to strDevice. Here, 'M' is set arbitrarily.

(2) C# Environment

A. High-Speed Link

```
uint processId = (uint)Process.GetCurrentProcess().Id;
```

- Part that receives ID of the current process.
- It is a necessary part to enable to call several programs related to RAPIEnet PC Card.

```
int[] nCardId = new int[16];
```

```
int[] nCardNo = new int[1];
```

- It is a necessary part to bring the number of PC Card mounted to RAPIEnet PC Card's handle.

```
m_RAPIEnetInterface.InitDevice(processId, nCardId, nCardNo);
```

- Function to set connection with RAPIEnet PC Card
- If it is called only once at the beginning, any connecting and setting work is not needed until the program is ended.

```
public int[] hCard = new int[5];
```

```
int nStation, nOffset, nSize;
```

```
string strDevice;
```

```
byte[] buffer = new byte[nSize];
```

```
m_RAPIEnetInterface.ReadDevice(hCard[index], nStation, strDevice, nOffset, nSize, out buffer[0]);
```

- hCard : RAPIEnet PC Card handle.
- nStation : Any station number is not used for high-speed link. (Set as 0)
- strDevice : It shall be set as 'HS' to use high-speed link.
- nOffset : The beginning location of data memory area to be received.
- nSize : The size of data to be received .
- buffer : The space in which data to be received are saved.

```
m_RAPIEnetInterface.WriteDevice(hCard[index], nStation, strDevice, nOffset, nSize, out buffer[0]);
```

- hCard : RAPIEnet PC Card handle.
- nStation : Any station number is not used for high-speed link. (Set as 0)
- strDevice : It shall be set as 'HS' to use high-speed link.
- nOffset : The beginning location of data memory area to send.
- nSize : The size of data to send.
- buffer : The space in which data to send are saved.

Example 1) offset : 0, size : 200, Sending

```
m_RAPIEnetInterface. WriteDevice(hCard[index], 0, 'HS', 0, 200, ref buffer[0])
```

Example 2) offset : 500, size : 150, Receiving

```
m_RAPIEnetInterface. ReadDevice(hCard[index], 0, 'HS', 500, 150, out buffer[0])
```

- For hCard, input the handle value to be brought from InitDevice.

B. P2P Service

GetCOMInterface()->InitDevice() Function is the same with that of high-speed link.

ReadDevice, WriteDevice variable type is the same with that of high-speed link.

```
m_RAPIEnetInterface.ReadDevice(hCard[index], nStation, strDevice, nOffset, nSize, out buffer[0]);
```

- hCard : RAPIEnet PC Card handle.
- nStationNo : Set it the station number of RAPIEnet to be received.
- strDevice : Set appropriate to the memory type of the received module. (ex) M, D...)
- nOffset : The beginning location of data memory area to be received.
- nSize : The size of data to be received .
- buffer : The space in which data to be received are saved.

```
m_RAPIEnetInterface.WriteDevice(hCard[index], nStation, strDevice, nOffset, nSize, out buffer[0]);
```

- hCard : RAPIEnet PC Card handle.
- nStationNo : Data to send shall be set the station number of the received RAPIEnet module .
- strDevice : Set the sent data appropriate to the memory type of the received RAPIEnet module. (ex) M, D...)
- nOffset : The beginning location of data memory area to send.
- nSize : The size of data to send.
- buffer : The space in which data to send are saved.

Example 1) offset : 300, size : 50, Sending

```
GetCOMInterface()->WriteDevice(hCard, 2, 'M', 300, 50);
```

Example 2) offset : 700, size : 100, Receiving

```
GetCOMInterface()->ReadDevice(hCard, 2, 'M', 700, 100);
```

- For hCard, input the handle value to be brought from InitDevice.
- Select the memory type of the module that communicates application values to strDevice. Here, ' M' is set arbitrarily.

13.3 Performance Measure

High-speed link means communication from PC to RAPIEnet PC Card on PC while P2P service refers to communication from PC to the module the user wants to communicate with via RAPIEnet PC Card. Therefore, the user may clearly see differences in the consumed time by checking the results of performance measure of high-speed link and P2P service.

Data Size(BYTE)	200	800	1000	2000	4000	8000	16000
Average Time(ms)	0.191	0.302	0.413	0.627	1.167	2.240	4.405
MAX (ms)	0.565	0.692	1.667	0.936	1.555	2.597	4.969
MIN (ms)	0.183	0.292	0.399	0.615	1.151	2.220	4.362

[Table 13.3.1] Performance Measure of High-Speed Link

Data Size(BYTE)	200	800	1000	2000	4000	8000	16000
Average Time(ms)	15.625	15.624	15.626	31.173	46.403	92.699	190.33
MAX (ms)	16.381	16.342	16.684	31.861	63.307	95.015	202.58
MIN (ms)	15.122	15.131	15.132	15.093	15.263	31.118	125.94

[Table 13.3.2] Performance Measure of P2P Service

The size of sent and received data may increase depending on their memory size but, the time to take in sending/receiving also increases in accordance with the increased data size. In addition, note that many factors such as Windows performance, computer loading and other external conditions may have influence since it is an application operated on Windows.

Chapter 14 Example Program of RAPIEnet PC Card

14.1 System Configuration

Before example programs are explained, a system on which you want to run example programs is configured as seen in [Figure 14.1.1].

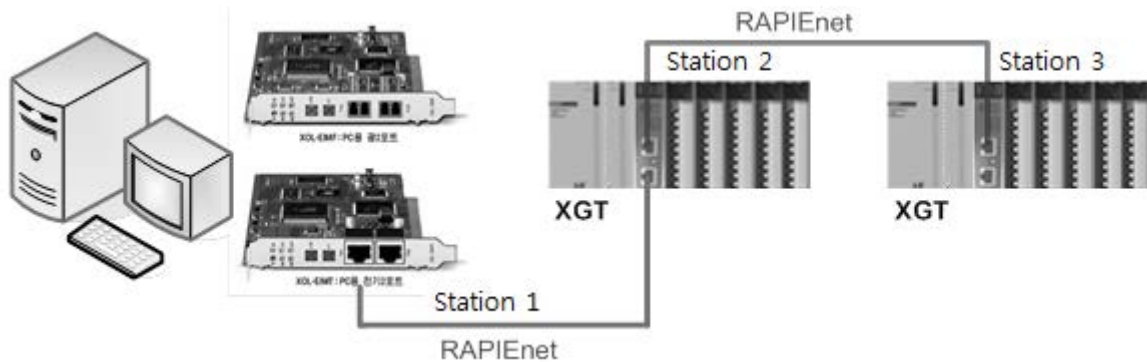

[Figure 14.1.1] System Configuration

More than two RAPIEnet PC Cards shall be installed on PC and one of RAPIEnet PC Cards shall be connected with PLC to form a communication network. The system block diagram in [Figure 14.1.1] shows a communication network arbitrarily made for testing an example program. It is not necessary to use the same configuration as in [Figure 14.1.1]. If RAPIEnet PC Card and RAPIEnet Module are connected, the example program can be tested. In addition, the connected RAPIEnet PC card and RAPIEnet module shall be set with different station number each other.

14.2 Example Program

The example program described in Chapter 14 is the one attached to C:\RAPIEnet-PD Installation Folder\examples\ folder after RAPIEnet-PD is installed. Example Program 실행 The screen to execute The example program is as seen in [Figure 14.2.1].



[Figure 14.2.1] Example Program screen

Refer to 14.2.1 High-Speed Link and 14.2.2 P2P service since they set an example program based on examples of sending/receiving data in [Table 14.2.1].

Sending/Receiving Structure		XGT I/O Configuration (The same throughout stations)	Sending Station	Receiving Station	Size
RAPIEnet PC Card (Station 1)	TX	Slot 0 : RAPIEnet Slot 1 : Output 32 points Slot 2 : Input 32 points	0	--	200
	RX : <-- XGT 2		--	500	150
	TX		200	--	100
	RX : <-- XGT 3		--	650	50
	TX		300	--	50
	RX : <-- XGT 2		--	700	100
	TX		350	--	150
	RX : <-- XGT 3		--	800	200

[Table 14.2.1] Example of I/O Configuration and Sending/Receiving Data

14.2.1 Configuration of Example Program

The example program is the one realized with C#. For knowing about how to register COM interface in C# environment, refer to Chapter 13-13.2.1. If it is found that RAPIEnetServiceLib is added by reviewing reference on the solution explorer, it means that COM Interface is normally registered. To use COM Interface, register it first.

A selected driver refers to part selecting a PC Card the user wants to use if several RAPIEnet PC cards have been installed. When reading or writing, size refers to the size of data to be sent or received. When reading or writing bits, size means bit location. It means that the value of the n^{th} bit location from the offset starting location

The default unit of Read and Write is Byte.

14.2.2 High-Speed Link

Based on [Table 14.2.1], parameter settings for high-speed link communication are as seen in [Table 14.2.2]. For TX, click on Write parameter, For RX, click on Read parameter. For high-speed link, set '0' for counterpart station number parameters and 'HS' for devices regardless of counterpart station numbers.

	Button	Counterpart Station Number	Device	Offset	Size
TX	Write Device	0	HS	0	200
RX(Station 2)	Read Device	0	HS	500	150
TX	Write Device	0	HS	200	100
RX(Station 3)	Read Device	0	HS	650	50
TX	Write Device	0	HS	300	50
RX(Station 2)	Read Device	0	HS	700	100
TX	Write Device	0	HS	350	150
RX(Station 3)	Read Device	0	HS	800	200

[Table 14.2.2] Parameter Setting of High-Speed Link

14.2.3 P2P

Based on [Table 14.2.1], parameter settings for P2P service are as seen in [Table 14.2.3]. Unlike settings for high-speed link, make sure to input the station number of RAPIEnet module you want to communicate with in the counterpart station number sector and write the type of the relevant memory in the device sector.

	Button	Counterpart Station Number	Device	Offset	Size
TX	Write Device	2	M	0	200
RX(Station 2)	Read Device	2	M	500	150
TX	Write Device	3	M	200	100
RX(Station 3)	Read Device	3	M	650	50
TX	Write Device	3	M	300	50
RX(Station 2)	Read Device	2	M	700	100
TX	Write Device	3	M	350	150
RX(Station 3)	Read Device	3	M	800	200

[Table 14.2.3] Parameter Setting of P2P Service

Chapter 15 Diagnosis Function of RAPIenet PC Card

15.1 Communication Module Information

RAPIenet PC Card's basic information is displayed. Click on 'Online' → 'RAPIenet Registration Information' on RAPIenet-PD or after selecting a relevant RAPIenet PC Card from the project window, click the right button of the mouse and then click on 'RAPIenet Registration Information' menu to open Information Screen of RAPIenet PC Card as seen in [Figure 15.1.1].



[Figure 15.1.1] RAPIenet PC Card Information Screen

Item	Sub Item	Description
Basic Information	Link Kind	The connected and selected link kind is displayed (RAPIenet PC Card)
	Action Mode	Action mode of this module is displayed. (RUN, BBM, DOWN)
	High-Speed Link	High-speed link Enable/ Disable is displayed.
Link Information	station number	Station number of this module is displayed
	Kind	Media kind of this module is displayed (electricity, optical)
	MAC ADDRESS	Mac address of this module is displayed
SW, HW Information	HW Version	Hardware version is displayed
	HW Status	Hardware status is displayed (Run, Down, Reset, Error)
	SW Version	Software version
	SW Date	Software date

[Table 15.1.1] Contents of RAPIenet PC Card Information

15.2 Auto Scan

The network system configuration state of the entire system can be checked. After clicking on RAPIEnet PC Card you want to auto scan on the project window, click on 'Online' → 'System Diagnosis' → 'Auto Scan' to open the Auto Scan Screen.

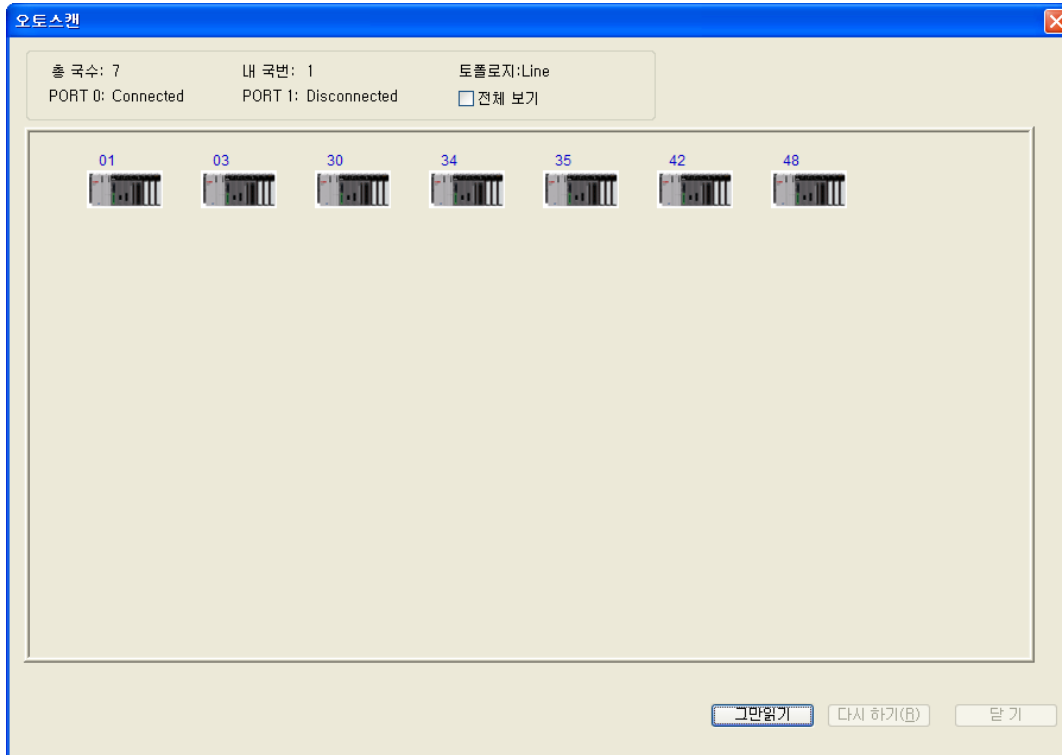

[Figure 15.2.1] Auto Scan Screen

Auto Scan Screen shows the following text information displayed on the upper area.

Item	Description
A total Number of Stations	A total number of RAPIEnet I/F modules connected with the network - Display Range: 0 ~ 63
My Station number	Station number of selected RAPIEnet PC Card - Display Range: 0 ~ 63
Topology	Display the system's network configuration status - SA : System without any connected module - LINE: Line-shape network system - RING: Ring-shape network system
PORT 0	Status of RAPIEnet PC Card의 PORT 0 - Display Content : Disconnected / Connected
PORT 1	Status of RAPIEnet PC Card의 PORT 1 - Display Content : Disconnected / Connected
View All	Display a total number of stations RAPIEnet can display and distinguish enabled modules and disenabled ones to convert them to a marked form

[Table 15.2.1] Auto Scan Content

In case of RAPIEnet PC Card's auto scan, only station numbers of the modules that are currently connected out of those in the entire system are known. The setting type of link between modules such as XG-PD cannot be known.

15.3 Media Diagnosis Program

The service or media status of RAPIenet PC Card can be checked with the number of packets. After clicking on RAPIenet PC Card whose media information you want to know on the project window, click on 'Online' → 'System Diagnosis' → 'Media Information' to open the Media Information Screen.

If you click on Consecutively Read on the bottom of the Media Information Screen, you may check status information and packet monitoring in real-time and identify the number of packets in a form of graph.

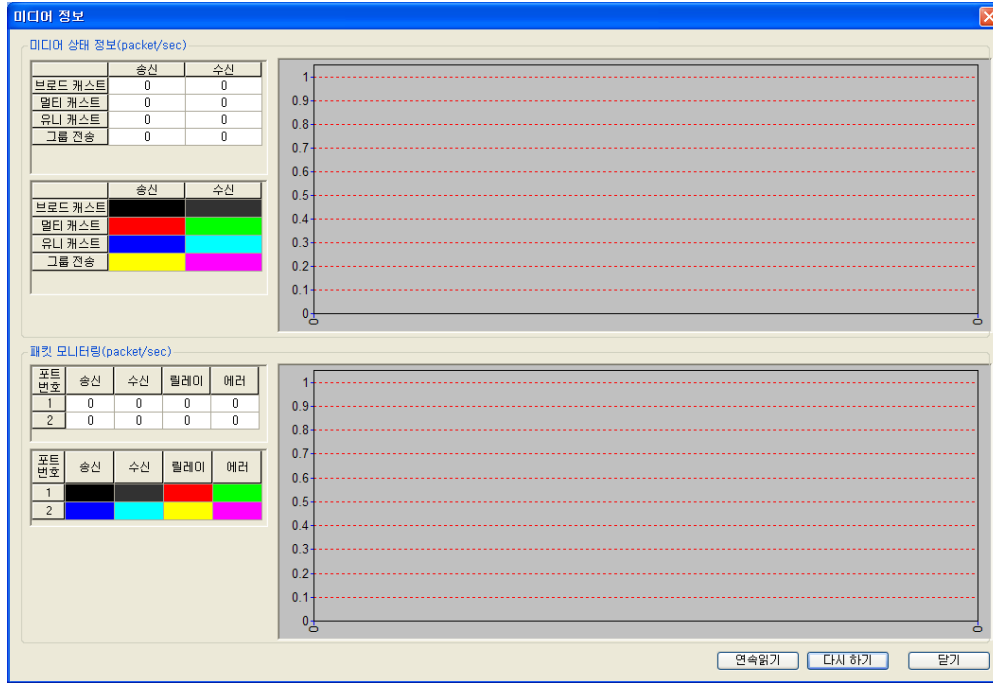

[Figure 15.3.1] Media Information Screen

Item	Sub Item	Description
Media Status Information (packet/second)	Broadcast	The number of packets per second of the frame sent/received in broadcast
	Multicast	The number of packets per second of the frame sent/received in multicast
	Unicast	The number of packets per second of the frame sent/received in unicast
	Group transmission	The number of packets per second of the frame sent/received in group transmission
Packet Monitoring (packet/second)	Sending	The number of packets per second of the frame sent on each port
	Receiving	The number of packets per second of the frame received on each port
	Relay	The number of packets per second of the frame relayed on each port
	Error	The number of packets per second of the error that incurs when sending/receiving on each port

[Figure 15.3.2] Media Information Contents

Appendix

A.1 Terminology

1. IEEE 802.3

IEEE 802.3 specifies standards for CSMA/CD based Ethernet. Exactly it is a LAN based on CSMA/CD (Carrier Sense Multiple Access with Collision Detection) Ethernet designed by IEEE 802.3 group, which is classified into detailed projects as specified below;

- A) IEEE P802.3 - 10G Base T study Group
- B) IEEE P802.3ah - Ethernet in the First Mile Task Force
- C) IEEE P802.3ak - 10G Base-CX4 Task Force

※ Ethernet and IEEE 802.3 are standardized at RFC894 and RFC1042 so each should process another frame.

2. Client

A user of the network service, or a computer or program (mainly the one requesting services) using other computer's resource.

3. CSMA/CD(Carrier Sense Multiple Access with Collision Detection)

Each client checks if there is any sign prior to transmission of data to the network (Carrier Sense) and then sends its data when the network is empty. At this time, all the clients have the equal right to send (Multiple Access). If two or more clients send data, collision may occur. The client who detects the collision tries to send again in a specific time.

4. Ethernet

A representative LAN connection system (IEEE 802.3) developed by Xerox, Intel and DEC of America which can send about 10Mbps and use the packet of 1.5kB. Since Ethernet can allow various types of computers to be connected as one via the network, it has been called a pronoun of LAN as a universal standard with various products available, not limited to some specific companies.

5. Header

Part of the packet including self station No., correspondent station No. and error checking area.

6. ISO (International Organization for Standardization)

A subsidiary organization of UN, establishing and managing the international standards.

7. LAN (Local Area Network)

Called also as local area communication network or district information communication network, which allows lots of computers to exchange data with each other as connected though communication cable within a limited area such as in an office or a building

8. MAC (Medium Access Control)

A method used to decide which device should use the network during given time on the broadcast network

9. Node

Each computer connected with the network is called Node

10. Packet

A package of data which is the basic unit used to send through the network. Usually the package is made of several tens or hundreds of bytes with the header attached in front to which its destination and other necessary information are added

11. Protocol

Contains regulations related with mutual information transmission method between computers connected with each other through the network. The protocol may specify detailed interface between machines in Low level (for example, which bit/byte should go out through the line) or high level of message exchange regulations as files are transferred through the Internet.

12. Server

It is the side that passively responding to the request of the client and sharing its source.

13. Near-end crosstalk

Near-end crosstalk affecting other near line is one of the disturbances made by electric or magnetic field of communication signal. Near-end crosstalk causes that some part of communication contents of other line may be heard in one line. Phenomenon made by near-end crosstalk is called Electro-magnetic interference (EMI). This can be occurred in network line or small circuit in the computer or audio device.

A.2 List of Flags

A.2.1 List of Special Relays (F)

Device 1	Device 2	Type	Variable	Function	Description
F0000		DWORD	_SYS_STATE	Mode & Status	PLC mode & run status displayed.
	F00000	BIT	_RUN	RUN	RUN status.
	F00001	BIT	_STOP	STOP	STOP status.
	F00002	BIT	_ERROR	ERROR	ERROR status.
	F00003	BIT	_DEBUG	DEBUG	DEBUG status.
	F00004	BIT	_LOCAL_CON	Local control	Local control mode.
	F00005	BIT	_MODBUS_CON	Modbus mode	Modbus control mode.
	F00006	BIT	_REMOTE_CON	Remote mode	Remote control mode.
	F00008	BIT	_RUN_EDIT_ST	Modification during run	Program being downloaded during run.
	F00009	BIT	_RUN_EDIT_CHK	Modification during run	Modification in progress during run.
	F0000A	BIT	_RUN_EDIT_DONE	Modification complete during run	Modification complete during run.
	F0000B	BIT	_RUN_EDIT_END	Modification complete during run	Modification complete during run.
	F0000C	BIT	_CMOD_KEY	Run Mode	Run Mode changed by key.
	F0000D	BIT	_CMOD_LPADT	Run Mode	Run Mode changed by local PADT.
	F0000E	BIT	_CMOD_RPADT	Run Mode	Run Mode changed by remote PADT.
	F0000F	BIT	_CMOD_RLINK	Run Mode	Run Mode changed by remote communication module.
	F00010	BIT	_FORCE_IN	Compulsory input	Compulsory input status.
	F00011	BIT	_FORCE_OUT	Compulsory output	Compulsory output status.
	F00012	BIT	_SKIP_ON	I/O SKIP	I/O SKIP being executed.
	F00013	BIT	_EMASK_ON	Error mask	Error mask being executed.
	F00014	BIT	_MON_ON	Monitor	Monitor being executed.
	F00015	BIT	_USTOP_ON	STOP	Stopped by STOP function
	F00016	BIT	_ESTOP_ON	ESTOP	Stopped by ESTOP function.
	F00017	BIT	_CONPILE_MODE	Compiling	Compile being performed.
	F00018	BIT	_INIT_RUN	Initializing	Initialization task being performed.
	F0001C	BIT	_PB1	Program code 1	Program code 1 selected.
	F0001D	BIT	_PB2	Program code 2	Program code 2 selected.

Appendix

Device 1	Device 2	Type	Variable	Function	Description
	F0001E	BIT	_CB1	Compile code 1	Compile code 1 selected.
	F0001F	BIT	_CB2	Compile code 2	Compile code 2 selected.
F0002		DWORD	_CNF_ER	System error	Serious error in system reported.
	F00020	BIT	_CPU_ER	CPU error	CPU configuration error found.
	F00021	BIT	_IO_TYER	Module type error	Module type not identical.
	F00022	BIT	_IO_DEER	Module installation error	Module displaced.
	F00023	BIT	_FUSE_ER	Fuse error	Fuse blown.
	F00024	BIT	_IO_RWER	Module I/O error	Module I/O error found.
	F00025	BIT	_IP_IFER	Module interface error	Error found in Special/communication module interface.
	F00026	BIT	_ANNUM_ER	External equipment Error	Serious error detected in external equipment.
	F00028	BIT	_BPRM_ER	Basic parameter	Basic parameter abnormal.
	F00029	BIT	_IOPRM_ER	IO parameter	IO configuration parameter abnormal.
	F0002A	BIT	_SPPRM_ER	Special module parameter	Special module parameter abnormal.
	F0002B	BIT	_CPPRM_ER	Communication module parameter	Communication module parameter abnormal.
	F0002C	BIT	_PGM_ER	Program error	Program error found.
	F0002D	BIT	_CODE_ER	Code error	Program code error found.
	F0002E	BIT	_SWDT_ER	System watch-dog	System watch-dog active.
	F0002F	BIT	_BASE_POWER_ER	Power error	Base power abnormal.
	F00030	BIT	_WDT_ER	Scan watch-dog	Scan watch-dog active.
F0004		DWORD	_CNF_WAR	System warning	Slight error in system reported.
	F00040	BIT	_RTC_ER	RTC error	RTC data abnormal.
	F00041	BIT	_DBCK_ER	Back-up error	Data back-up error found.
	F00042	BIT	_HBCK_ER	Restart error	Hot restart unavailable.
	F00043	BIT	_ABSD_ER	Run error stop	Stopped due to abnormal run.
	F00044	BIT	_TASK_ER	Task impact	Task being impacted.
	F00045	BIT	_BAT_ER	Battery error	Battery status abnormal.
	F00046	BIT	_ANNUM_WAR	External equipment error	Slight error detected in external equipment.
	F00047	BIT	_LOG_FULL	Memory full	Log memory full
	F00048	BIT	_HS_WAR1	HS link 1	HS link – parameter 1 error
	F00049	BIT	_HS_WAR2	HS link 2	HS link – parameter 2 error
	F0004A	BIT	_HS_WAR3	HS link 3	HS link – parameter 3 error
	F0004B	BIT	_HS_WAR4	HS link 4	HS link – parameter 4 error

Device 1	Device 2	Type	Variable	Function	Description
	F0004C	BIT	_HS_WAR5	HS link 5	HS link – parameter 5 error
	F0004D	BIT	_HS_WAR6	HS link 6	HS link – parameter 6 error
	F0004E	BIT	_HS_WAR7	HS link 7	HS link – parameter 7 error
	F0004F	BIT	_HS_WAR8	HS link 8	HS link – parameter 8 error
	F00050	BIT	_HS_WAR9	HS link 9	HS link – parameter 9 error
	F00051	BIT	_HS_WAR10	HS link 10	HS link – parameter 10 error
	F00052	BIT	_HS_WAR11	HS link 11	HS link - parameter11 error
	F00053	BIT	_HS_WAR12	HS link 12	HS link - parameter12 error
	F00054	BIT	_P2P_WAR1	P2P parameter 1	P2P - parameter1 error
	F00055	BIT	_P2P_WAR2	P2P parameter 2	P2P – parameter2 error
	F00056	BIT	_P2P_WAR3	P2P parameter 3	P2P – parameter3 error
	F00057	BIT	_P2P_WAR4	P2P parameter 4	P2P – parameter4 error
	F00058	BIT	_P2P_WAR5	P2P parameter 5	P2P – parameter5 error
	F00059	BIT	_P2P_WAR6	P2P parameter 6	P2P – parameter6 error
	F0005A	BIT	_P2P_WAR7	P2P parameter 7	P2P – parameter7 error
	F0005B	BIT	_P2P_WAR8	P2P parameter 8	P2P – parameter8 error
	F0005C	BIT	_CONSTANT_ER	Fixed cycle error	Fixed cycle error
F0009		WORD	_USER_F	User contact point	Timer available for user.
	F00090	BIT	_T20MS	20ms	CLOCK of 20ms cycle.
	F00091	BIT	_T100MS	100ms	CLOCK of 100ms cycle.
	F00092	BIT	_T200MS	200ms	CLOCK of 200ms cycle.
	F00093	BIT	_T1S	1s	CLOCK of 1s cycle.
	F00094	BIT	_T2S	2s	CLOCK of 2s cycle.
	F00095	BIT	_T10S	10s	CLOCK of 10s cycle.
	F00096	BIT	_T20S	20s	CLOCK of 20s cycle.
	F00097	BIT	_T60S	60s	CLOCK of 60s cycle.
	F00099	BIT	_ON	Always ON	Bit always ON.
	F0009A	BIT	_OFF	Always OFF	Bit always OFF
	F0009B	BIT	_1ON	1 scan ON	Bit only ON for the first scan.
	F0009C	BIT	_1OFF	1 scan OFF	Bit only OFF for the first scan.
	F0009D	BIT	_STOG	Reverse	Every scan reversed.
F0010		WORD	_USER_CLK	User CLOCK	CLOCK available to set by user.
	F00100	BIT	_USR_CLK0	Repeat specific scan	ON/OFF CLOCK 0 for specific scan
	F00101	BIT	_USR_CLK1	Repeat specific scan	ON/OFF CLOCK 1 for specific scan

Appendix

Device 1	Device 2	Type	Variable	Function	Description
	F00102	BIT	_USR_CLK2	Repeat specific scan	ON/OFF CLOCK 2 for specific scan
	F00103	BIT	_USR_CLK3	Repeat specific scan	ON/OFF CLOCK 3 for specific scan
	F00104	BIT	_USR_CLK4	Repeat specific scan	ON/OFF CLOCK 4 for specific scan
	F00105	BIT	_USR_CLK5	Repeat specific scan	ON/OFF CLOCK 5 for specific scan
	F00106	BIT	_USR_CLK6	Repeat specific scan	ON/OFF CLOCK 6 for specific scan
	F00107	BIT	_USR_CLK7	Repeat specific scan	ON/OFF CLOCK 7 for specific scan
F0011		WORD	_LOGIC_RESULT	Logic result	Logic result displayed.
	F00110	BIT	_LER	Calculation error	ON for 1 scan if calculation in error.
	F00111	BIT	_ZERO	Zero flag	ON if calculation result is 0.
	F00112	BIT	_CARRY	Carry flag	ON if Carry found during calculation.
	F00113	BIT	_ALL_OFF	Whole output OFF	ON if all output OFF
	F00115	BIT	_LER_LATCH	Calculation error latch	ON kept if calculation in error.
F0012		WORD	_CMP_RESULT	Compared result	Compared result displayed.
	F00120	BIT	_LT	LT flag	ON if "less than"
	F00121	BIT	_LTE	LTE flag	ON if "less than or equal"
	F00122	BIT	_EQU	EQU flag	ON if "equal"
	F00123	BIT	_GT	GT flag	ON if "greater than"
	F00124	BIT	_GTE	GTE flag	ON if "greater than or equal"
	F00125	BIT	_NEQ	NEQ flag	ON if "not equal"
F0013		WORD	_AC_F_CNT	Inspected power cut	Number of inspected power-cuts displayed.
F0014		WORD	_FALS_NUM	FALS No.	FALS No. displayed.
F0015		WORD	_PUTGET_ERR0	PUT/GET error 0	Main base PUT / GET error
F0016		WORD	_PUTGET_ERR1	PUT/GET error 1	Added base step 1 PUT / GET error
F0017		WORD	_PUTGET_ERR2	PUT/GET error 2	Added base step 2 PUT / GET error
F0018		WORD	_PUTGET_ERR3	PUT/GET error 3	Added base step 3 PUT / GET error
F0019		WORD	_PUTGET_ERR4	PUT/GET error 4	Added base step 4 PUT / GET error
F0020		WORD	_PUTGET_ERR5	PUT/GET error 5	Added base step 5 PUT / GET error
F0021		WORD	_PUTGET_ERR6	PUT/GET error 6	Added base step 6 PUT / GET error
F0022		WORD	_PUTGET_ERR7	PUT/GET error 7	Added base step 7 PUT / GET error
F0023		WORD	_PUTGET_NDR0	PUT/GET complete 0	Main base PUT / GET complete
F0024		WORD	_PUTGET_NDR1	PUT/GET complete 1	Added base step 1 PUT / GET complete
F0025		WORD	_PUTGET_NDR2	PUT/GET complete 2	Added base step 2 PUT / GET complete
F0026		WORD	_PUTGET_NDR3	PUT/GET complete 3	Added base step 3 PUT / GET complete
F0027		WORD	_PUTGET_NDR4	PUT/GET complete 4	Added base step 4 PUT / GET complete
F0028		WORD	_PUTGET_NDR5	PUT/GET complete 5	Added base step 5 PUT / GET complete

Device 1	Device 2	Type	Variable	Function	Description
F0029		WORD	_PUTGET_NDR6	PUT/GET complete 6	Added base step 6 PUT / GET complete
F0030		WORD	_PUTGET_NDR7	PUT/GET complete 7	Added base step 7 PUT / GET complete
F0044		WORD	_CPU_TYPE	CPU type	Information on CPU type displayed.
F0045		WORD	_CPU_VER	CPU version	CPU version displayed.
F0046		DWORD	_OS_VER	OS version	OS version displayed.
F0048		DWORD	_OS_DATE	OS date	OS released date displayed.
F0050		WORD	_SCAN_MAX	Max. scan time	Max. scan time displayed
F0051		WORD	_SCAN_MIN	Min. scan time	Min. scan time displayed
F0052		WORD	_SCAN_CUR	Present scan time	Present scan time displayed.
F0053		WORD	_MON_YEAR	Month / Year	PLC's time information (Month/Year)
F0054		WORD	_TIME_DAY	Hour / Date	PLC's time information (Hour/Date)
F0055		WORD	_SEC_MIN	Second / Minute	PLC's time information (Second/Minute)
F0056		WORD	_HUND_WK	100 years / Day	PLC's time information (100 years/Day)
F0057		WORD	_FPU_INFO	FPU calculation result	Floating decimal calculation result displayed.
	F00570	BIT	_FPU_LFLAG_I	Incorrect error latch	Latched if in incorrect error.
	F00571	BIT	_FPU_LFLAG_U	Underflow latch	Latched if underflow found.
	F00572	BIT	_FPU_LFLAG_O	Overflow latch	Latched if overflow found.
	F00573	BIT	_FPU_LFLAG_Z	Latch divided by 0	Latched if divided by 0.
	F00574	BIT	_FPU_LFLAG_V	Invalid calculation latch	Latched if invalid calculation.
	F0057A	BIT	_FPU_FLAG_I	Incorrect error	Reported if incorrect error found.
	F0057B	BIT	_FPU_FLAG_U	Underflow	Reported if underflow found.
	F0057C	BIT	_FPU_FLAG_O	Overflow	Reported if overflow found.
	F0057D	BIT	_FPU_FLAG_Z	Division by 0	Reported if divided by 0.
	F0057E	BIT	_FPU_FLAG_V	Invalid calculation	Reported if calculation invalid.
	F0057F	BIT	_FPU_FLAG_E	Irregular value input	Reported if irregular value input.
F0058		DWORD	_ERR_STEP	Error step	Error step saved.
F0060		DWORD	_REF_COUNT	Refresh	Increased when module refresh executed.
F0062		DWORD	_REF_OK_CNT	Refresh OK	Increased if module refresh normal
F0064		DWORD	_REF_NG_CNT	Refresh NG	Increased if module refresh abnormal.
F0066		DWORD	_REF_LIM_CNT	Refresh LIMIT	Increased if module refresh abnormal (TIME OUT).
F0068		DWORD	_REF_ERR_CNT	Refresh ERROR	Increased if module refresh abnormal.
F0070		DWORD	_MOD_RD_ERR_CNT	Module READ ERROR	Increased if module reads 1 word abnormally.
F0072		DWORD	_MOD_WR_ERR_CNT	Module WRITE ERROR	Increased if module writes 1 word abnormally.

Appendix

Device 1	Device 2	Type	Variable	Function	Description
F0074		DWORD	_CA_CNT	Block service	Increased if module's block data serviced
F0076		DWORD	_CA_LIM_CNT	Block service LIMIT	Increased if module's block data service abnormal.
F0078		DWORD	_CA_ERR_CNT	Block service ERROR	Increased if module's block data service abnormal.
F0080		DWORD	_BUF_FULL_CNT	Buffer FULL	Increased if CPU's internal buffer is FULL.
F0082		DWORD	_PUT_CNT	PUT count	Increased if PUT executed.
F0084		DWORD	_GET_CNT	GET count	Increased if GET executed.
F0086		DWORD	_KEY	Present key	Local key's present status displayed.
F0088		DWORD	_KEY_PREV	Previous key	Local key's previous status displayed.
F0090		WORD	_IO_TYER_N	Discordant slot	Slot number with discordant module type displayed.
F0091		WORD	_IO_DEER_N	Displaced slot	Slot number with displaced module displayed.
F0092		WORD	_FUSE_ER_N	Fuse blown slot	Slot number with fuse blown displayed.
F0093		WORD	_IO_RWER_N	RW error slot	Slot number with module Read/Write error displayed.
F0094		WORD	_IP_IFER_N	IF error slot	Slot number with module interface error displayed.
F0096		WORD	_IO_TYER0	Module type 0 error	Main base module type error.
F0097		WORD	_IO_TYER1	Module type 1 error	Added base step 1 module type error.
F0098		WORD	_IO_TYER2	Module type 2 error	Added base step 2 module type error.
F0099		WORD	_IO_TYER3	Module type 3 error	Added base step 3 module type error.
F0100		WORD	_IO_TYER4	Module type 4 error	Added base step 4 module type error.
F0101		WORD	_IO_TYER5	Module type 5 error	Added base step 5 module type error
F0102		WORD	_IO_TYER6	Module type 6 error	Added base step 6 module type error
F0103		WORD	_IO_TYER7	Module type 7 error	Added base step 7 module type error
F0104		WORD	_IO_DEER0	Module installation 0 error	Main base module installation error
F0105		WORD	_IO_DEER1	Module installation 1 error	Added base step 1 module installation error
F0106		WORD	_IO_DEER2	Module installation 2 error	Added base step 2 module installation error
F0107		WORD	_IO_DEER3	Module installation 3 error	Added base step 3 module installation error
F0108		WORD	_IO_DEER4	Module installation 4 error	Added base step 4 module installation error
F0109		WORD	_IO_DEER5	Module installation 5 error	Added base step 5 module installation error
F0110		WORD	_IO_DEER6	Module installation 6 error	Added base step 6 module installation error
F0111		WORD	_IO_DEER7	Module installation 7 error	Added base step 7 module installation error
F0112		WORD	_FUSE_ER0	Fuse blown 0 error	Main base Fuse blown error
F0113		WORD	_FUSE_ER1	Fuse blown 1 error	Added base step 1 Fuse blown error
F0114		WORD	_FUSE_ER2	Fuse blown 2 error	Added base step 2 Fuse blown error
F0115		WORD	_FUSE_ER3	Fuse blown 3 error	Added base step 3 Fuse blown error

Device 1	Device 2	Type	Variable	Function	Description
F0116		WORD	_FUSE_ER4	Fuse blown 4 error	Added base step 4 Fuse blown error
F0117		WORD	_FUSE_ER5	Fuse blown 5 error	Added base step 5 Fuse blown error
F0118		WORD	_FUSE_ER6	Fuse blown 6 error	Added base step 6 Fuse blown error
F0119		WORD	_FUSE_ER7	Fuse blown 7 error	Added base step 7 Fuse blown error
F0120		WORD	_IO_RWER0	Module RW 0 error	Main base module Read/Write error
F0121		WORD	_IO_RWER1	Module RW 1 error	Added base step 1 module Read/Write error
F0122		WORD	_IO_RWER2	Module RW 2 error	Added base step 2 module Read/Write error
F0123		WORD	_IO_RWER3	Module RW 3 error	Added base step 3 module Read/Write error
F0124		WORD	_IO_RWER4	Module RW 4 error	Added base step 4 module Read/Write error
F0125		WORD	_IO_RWER5	Module RW 5 error	Added base step 5 module Read/Write error
F0126		WORD	_IO_RWER6	Module RW 6 error	Added base step 6 module Read/Write error
F0127		WORD	_IO_RWER7	Module RW 7 error	Added base step 7 module Read/Write error
F0128		WORD	_IO_IFER_0	Module IF 0 error	Main base module interface error
F0129		WORD	_IO_IFER_1	Module IF 1 error	Added base step 1 module interface error
F0130		WORD	_IO_IFER_2	Module IF 2 error	Added base step 2 module interface error
F0131		WORD	_IO_IFER_3	Module IF 3 error	Added base step 3 module interface error
F0132		WORD	_IO_IFER_4	Module IF 4 error	Added base step 4 module interface error
F0133		WORD	_IO_IFER_5	Module IF 5 error	Added base step 5 module interface error
F0134		WORD	_IO_IFER_6	Module IF 6 error	Added base step 6 module interface error
F0135		WORD	_IO_IFER_7	Module IF 7 error	Added base step 7 module interface error
F0136		WORD	_RTC_DATE	RTC date	RTC's present date
F0137		WORD	_RTC_WEEK	RTC day	RTC's present day of the week
F0138		DWORD	_RTC_TOD	RTC time	RTC's present time (ms unit)
F0140		DWORD	_AC_FAIL_CNT	Power-cut times	Power-cut times saved.
F0142		DWORD	_ERR_HIS_CNT	Errors found	Number of found errors saved.
F0144		DWORD	_MOD_HIS_CNT	Mode conversion times	Mode conversion times saved.
F0146		DWORD	_SYS_HIS_CNT	History updated times	System's history updated times saved.

Appendix

Device 1	Device 2	Type	Variable	Function	Description
F0148		DWORD	_LOG_ROTATE	Log rotate	Log rotate information saved.
F0150		WORD	_BASE_INFO0	Slot information 0	Main base slot information
F0151		WORD	_BASE_INFO1	Slot information 1	Added base step 1 slot information
F0152		WORD	_BASE_INFO2	Slot information 2	Added base step 2 slot information
F0153		WORD	_BASE_INFO3	Slot information 3	Added base step 3 slot information
F0154		WORD	_BASE_INFO4	Slot information 4	Added base step 4 slot information
F0155		WORD	_BASE_INFO5	Slot information 5	Added base step 5 slot information
F0156		WORD	_BASE_INFO6	Slot information 6	Added base step 6 slot information
F0157		WORD	_BASE_INFO7	Slot information 7	Added base step 7 slot information
F0158		WORD	_RBANK_NUM	Used block number	Presently used block number
F0159		WORD	_RBLOCK_STATE	Flash status	Flash block status
F0160		DWORD	_RBLOCK_RD_FL AG	Flash Read	ON when reading Flash N block data.
F0162		DWORD	_RBLOCK_WR_FL AG	Flash Write	ON when writing Flash N block data.
F0164		DWORD	_RBLOCK_ER_FL AG	Flash error	Error found during Flash N block service.
F1024		WORD	_USER_WRITE_F	Available contact	Contact point available in program
	F10240	BIT	_RTC_WR	RTC RW	Data Write & Read in RTC
	F10241	BIT	_SCAN_WR	Scan WR	Scan value initialization
	F10242	BIT	_CHK_ANC_ERR	Detect external serious error	Detection of serious error in external equipment requested.
	F10243	BIT	_CHK_ANC_WAR	Detect external slight error	Detection of slight error in external equipment requested.
F1025		WORD	_USER_STAUS_F	User contact point	User contact point
	F10250	BIT	_INIT_DONE	Initialization complete	Initialization complete displayed.
F1026		WORD	_ANC_ERR	External serious error information	Serious error information in external equipment displayed.
F1027		WORD	_ANC_WAR	External slight error information	Slight error information in external equipment displayed.
F1034		WORD	_MON_YEAR_DT	Month / Year	Time information data (Month/Year)
F1035		WORD	_TIME_DAY_DT	Hour / Date	Time information data (Hour/Date)
F1036		WORD	_SEC_MIN_DT	Second / Minute	Time information data (Second/Minute)
F1037		WORD	_HUND_WK_DT	100 years / Day	Time information data (100 years/Day)

A.2.2 List of Communication Relays (L)

- Special register for data

* HS link No. 1

No.	Keyword	Type	Detail	Description
L000000	_HS1_RLINK	Bit	HS link parameter No.1's all stations normally operated	Displays all stations normally operated as specified in HS link parameter, which will be On if 1. There is no error with all stations specified in parameter in RUN mode 2. All data block is in normal communication as specified in parameter. 3. The parameter specified in each station itself is in normal communication. Run_link will be kept On if once On until stopped by link disenable.
L000001	_HS1_LTRBL	Bit	After _HS1RLINK is ON, abnormal status displayed	This flag will be On if the station specified in parameter and the data block's communication status are as described below with _HSmRLINK flag On, 1. when the station specified in parameter is not in RUN mode, 2. when the station specified in parameter is in error, 3. when data block's communication status specified in parameter is unstable, The link trouble will be On if one of those conditions 1,2 and 3 above occurs. And if such a condition is back to normal, it will be Off.
L000020 ~ L00009F	_HS1_STATE[k] (k=000~127)	Bit Array	HS link parameter No.1, Block No.k's general status displayed	Displays the general status of the communication information for the specified parameter's respective data blocks. HS1STATE[k]=HS1MOD[k]&_HS1TRX[k]&(~_HSmERR[k])
L000100 ~ L00017F	_HS1_MOD[k] (k=000~127)	Bit Array	HS link parameter No.1, Block No.k station's Run operation mode	Displays the operation mode of the station specified in parameter's data block k.
L000180 ~ L00025F	_HS1_TRX[k] (k=000~127)	Bit Array	Normal communication displayed with HS link parameter No.1, Block No.k station	Displays the communication status of parameter's data block k to check if normal as specified.
L000260 ~ L00033F	_HS1_ERR[k] (k=000~127)	Bit Array	HS link parameter No.1, Block No.k station's Run error mode	Displays the communication status of parameter's data block k to check for any error.
L000340 ~ L00041F	_HS1_SETBLOCK (k=000~127)	Bit Array	HS link parameter No.1, Block No.k setting displayed	Displays the setting status of parameter's data block k.

[Table A.1] List of communication flags based on HS link number

K as a block number is displayed through 8 words by 16 for 1 word for the information of 128 blocks from 000 to 127. For example, block information of 16~31, 32~47, 48~63, 64~79, 80~95, 96~111, 112~127 will be displayed in L00011, L00012, L00013, L00014, L00015, L00016, L00017 from block 0 to block 15 for mode information (_HS1MOD).

* High speed link number 2~12

HS link No.	L area address	Remarks
2	L000500~L00099F	Compared with HS link of 1 in [Table 1], other HS link station number's flag address will be simply calculated as follows; *Calculation formula: L area address = L000000 + 500 x (HS link No. - 1) In order to use HS link flag for program and monitoring, use the flag map registered in XG5000 for convenient application.
3	L001000~L00149F	
4	L001500~L00199F	
5	L002000~L00249F	
6	L002500~L00299F	
7	L003000~L00349F	
8	L003500~L00399F	
9	L004000~L00449F	
10	L004500~L00499F	
11	L005000~L00549F	

[Table 2] Relation between high speed link and L device

Appendix

P2P parameters: 1~8, P2P block: 0~63

No.	Keyword	Type	Detail	Description
L006250	_P2P1_NDR00	Bit	P2P parameter No.1, block No.00 service complete normally	P2P parameter No.1, block No.0 service complete normally
L006251	_P2P1_ERR00	Bit	P2P parameter No.1, block No.00 service complete abnormally	P2P parameter No.1, block No.0 service complete abnormally
L00626	_P2P1_STATUS00	Word	Error code if P2P parameter No.1, block No.00 service complete abnormally	Error code displayed if P2P parameter No.1, block No.0 service complete abnormally
L00627	_P2P1_SVCCNT00	DWord	P2P parameter No.1, block No.00 service normal execution times	P2P parameter No.1, block No.0 service normal execution times displayed
L00629	_P2P1_ERRCNT00	DWord	P2P parameter No.1, block No.00 service abnormal execution times	P2P parameter No.1, block No.0 service abnormal execution times displayed
L006310	_P2P1_NDR01	Bit	P2P parameter No.1, block No.01 service complete normally	P2P parameter No.1, block No.1 service complete normally
L006311	_P2P1_ERR01	Bit	P2P parameter No.1, block No.01 service complete abnormally	P2P parameter No.1, block No.1 service complete abnormally
L00632	_P2P1_STATUS01	Word	Error code if P2P parameter No.1, block No.01 service complete abnormally	Error code displayed if P2P parameter No.1, block No.1 service complete abnormally
L00633	_P2P1_SVCCNT01	DWord	P2P parameter No.1, block No.01 service normal execution times	P2P parameter No.1, block No.1 service normal execution times displayed
L00635	_P2P1_ERRCNT01	DWord	P2P parameter No.1, block No.01 service abnormal execution times	P2P parameter No.1, block No.1 service abnormal execution times displayed

[Table 3] List of communication flags based on P2P service setting

A.2.3 List of Link device (N)

- Device saving the size and contents about P2P number and block number

- P2P No.: 1 ~ 8, P2P block: 0 ~ 63

No.	Keyword	Type	Detail	Description
N00000	_P1B00SN	Word	P2P parameter No.1, block No.00's correspondent station No.	P2P parameter No.1, block No.00's correspondent station No. saved Use P2PSN command to modify during Run if correspondent station number is used in XG5000.
N00001 ~ N00004	_P1B00RD1	Device structure	P2P parameter No.1, block No.00 area device 1 to read	P2P parameter No.1, block No.00 area device 1 to read saved
N00005	_P1B00RS1	Word	P2P parameter No.1, block No.00 area size 1 to read	P2P parameter No.1, block No.00 area size 1 to read saved
N00006 ~ N00009	_P1B00RD2	Device structure	P2P parameter No.1, block No.00 area device 2 to read	P2P parameter No.1, block No.00 area device 2 to read saved
N00010	_P1B00RS2	Word	P2P parameter No.1, block No.00 area size 2 to read	P2P parameter No.1, block No.00 area size 2 to read saved
N00011 ~ N00014	_P1B00RD3	Device structure	P2P parameter No.1, block No.00 area device 3 to read	P2P parameter No.1, block No.00 area device 3 to read saved
N00015	_P1B00RS3	Word	P2P parameter No.1, block No.00 area size 3 to read	P2P parameter No.1, block No.00 area size 3 to read saved
N00016 ~ N00019	_P1B00RD4	Device structure	P2P parameter No.1, block No.00 area device 4 to read	P2P parameter No.1, block No.00 area device 4 to read saved
N00020	_P1B00RS4	Word	P2P parameter No.1, block No.00 area size 4 to read	P2P parameter No.1, block No.00 area size 4 to read saved
N00021 ~ N00024	_P1B00WD1	Device structure	P2P parameter No.1, block No.00 saved area device 1	P2P parameter No.1, block No.00 saved area device 1 saved
N00025	_P1B00WS1	Word	P2P parameter No.1, block No.00 saved area size 1	P2P parameter No.1, block No.00 saved area size 1 saved
N00026 ~ N00029	_P1B00WD2	Device structure	P2P parameter No.1, block No.00 saved area device 2	P2P parameter No.1, block No.00 saved area device 2 saved
N00030	_P1B00WS2	Word	P2P parameter No.1, block No.00 saved area size 2	P2P parameter No.1, block No.00 saved area size 2 saved
N00031 ~ N00034	_P1B00WD3	Device structure	P2P parameter No.1, block No.00 saved area device 3	P2P parameter No.1, block No.00 saved area device 3 saved
N00035	_P1B00WS3	Word	P2P parameter No.1, block No.00 saved area size 3	P2P parameter No.1, block No.00 saved area size 3 saved
N00036 ~ N00039	_P1B00WD4	Device structure	P2P parameter No.1, block No.00 saved area device 4	P2P parameter No.1, block No.00 saved area device 4 saved
N00040	_P1B00WS4	Word	P2P parameter No.1, block No.00 saved area size 4	P2P parameter No.1, block No.00 saved area size 4 saved
N00041	_P1B01SN	Word	P2P parameter No.1, block No.01 correspondent station No.	P2P parameter No.1, block No.01's correspondent station No. saved Use P2PSN command to modify during Run if correspondent station number is used in XG.
N00042 ~ N00045	_P1B01RD1	Device structure	P2P parameter No.1, block No.01 area device 1 to read	P2P parameter No.1, block No.01 area device 1 to read saved
N00046	_P1B01RS1	Word	P2P parameter No.1, block No.01 area size 1 to read	P2P parameter No.1, block No.01 area size 1 to read saved
N00047 ~ N00050	_P1B01RD2	Device structure	P2P parameter No.1, block No.01 area device 2 to read	P2P parameter No.1, block No.01 area device 2 to read saved

Appendix

No.	Keyword	Type	Detail	Description
N00051	_P1B01RS2	Word	P2P parameter No.1, block No.01 area size 2 to read	P2P parameter No.1, block No.01 area size 2 to read saved
N00052 ~ N00055	_P1B01RD3	Device structure	P2P parameter No.1, block No.01 area device 3 to read	P2P parameter No.1, block No.01 area device 3 to read saved
N00056	_P1B01RS3	Word	P2P parameter No.1, block No.01 area size 3 to read	P2P parameter No.1, block No.01 area size 3 to read saved
N00057 ~ N00060	_P1B01RD4	Device structure	P2P parameter No.1, block No.01 area device 4 to read	P2P parameter No.1, block No.01 area device 4 to read saved
N00061	_P1B01RS4	Word	P2P parameter No.1, block No.01 area size 4 to read	P2P parameter No.1, block No.01 area size 4 to read saved
N00062 ~ N00065	_P1B01WD1	Device structure	P2P parameter No.1, block No.01 saved area device 1	P2P parameter No.1, block No.01 saved area device 1 saved
N00066	_P1B01WS1	Word	P2P parameter No.1, block No.01 saved area size 1	P2P parameter No.1, block No.01 saved area size 1 saved
N00067 ~ N00070	_P1B01WD2	Device structure	P2P parameter No.1, block No.01 saved area device 2	P2P parameter No.1, block No.01 saved area device 2 saved
N00071	_P1B01WS2	Word	P2P parameter No.1, block No.01 saved area size 2	P2P parameter No.1, block No.01 saved area size 2 saved
N00072 ~ N00075	_P1B01WD3	Device structure	P2P parameter No.1, block No.01 saved area device 3	P2P parameter No.1, block No.01 saved area device 3 saved
N00076	_P1B01WS3	Word	P2P parameter No.1, block No.01 saved area size 3	P2P parameter No.1, block No.01 saved area size 3 saved
N00077 ~ N00080	_P1B01WD4	Device structure	P2P parameter No.1, block No.01 saved area device 4	P2P parameter No.1, block No.01 saved area device 4 saved
N00081	_P1B01WS4	Word	P2P parameter No.1, block No.01 saved area size 4	P2P parameter No.1, block No.01 saved area size 4 saved

Notes

- 1) If P2P parameters are to be specified with XG5000 used for N area, the setting will be performed automatically. And its modification during Run is also available by P2P dedicated command.
- 2) Since the addresses of N area available are classified according to P2P parameter setting No. and block index No., the area not used for P2P service can be used as an internal device.

A.3 Dimension

Unit: mm

• XGL-EIMT/EIMF/EIMH

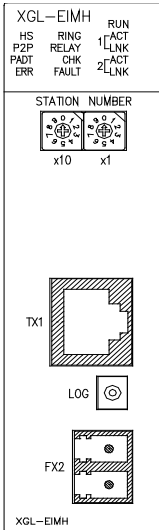
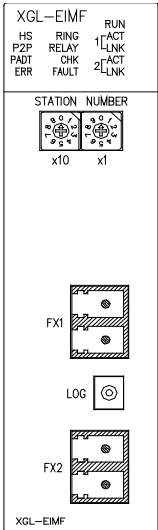
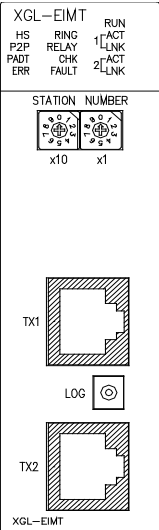
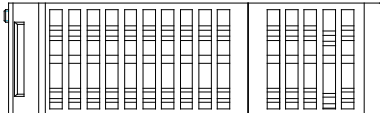
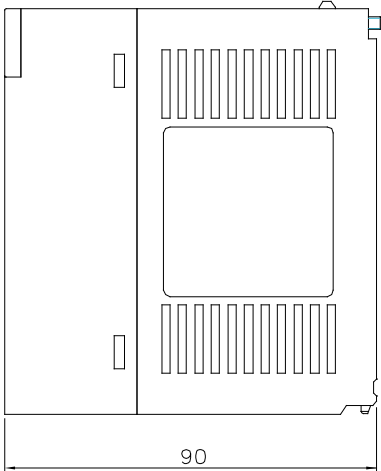
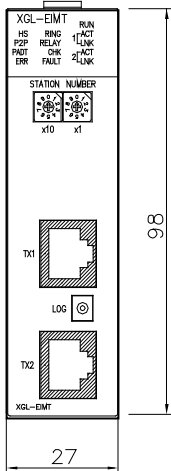
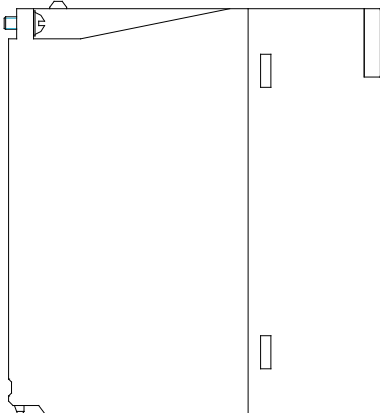
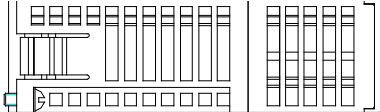

• XOL-EIMT/EIMF

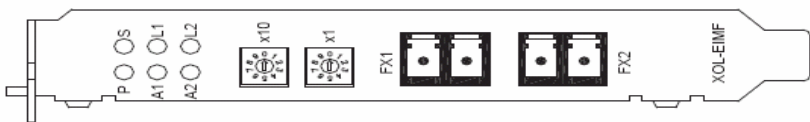
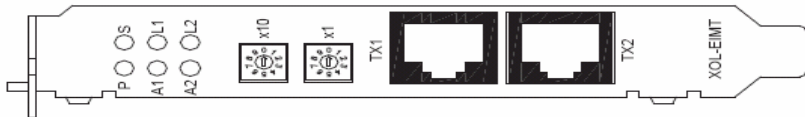
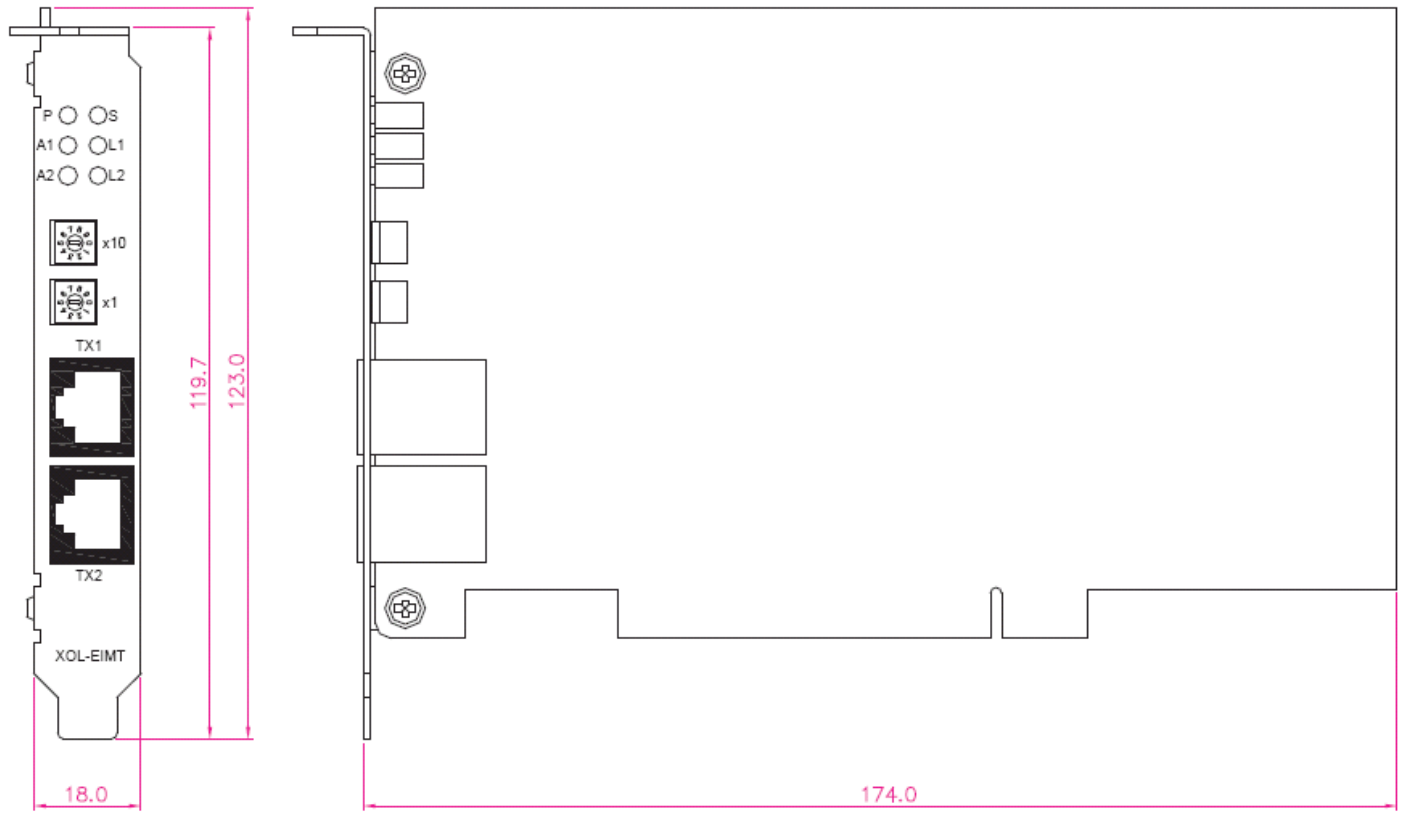

• XBL-EIMT/ EIMF/EIMH

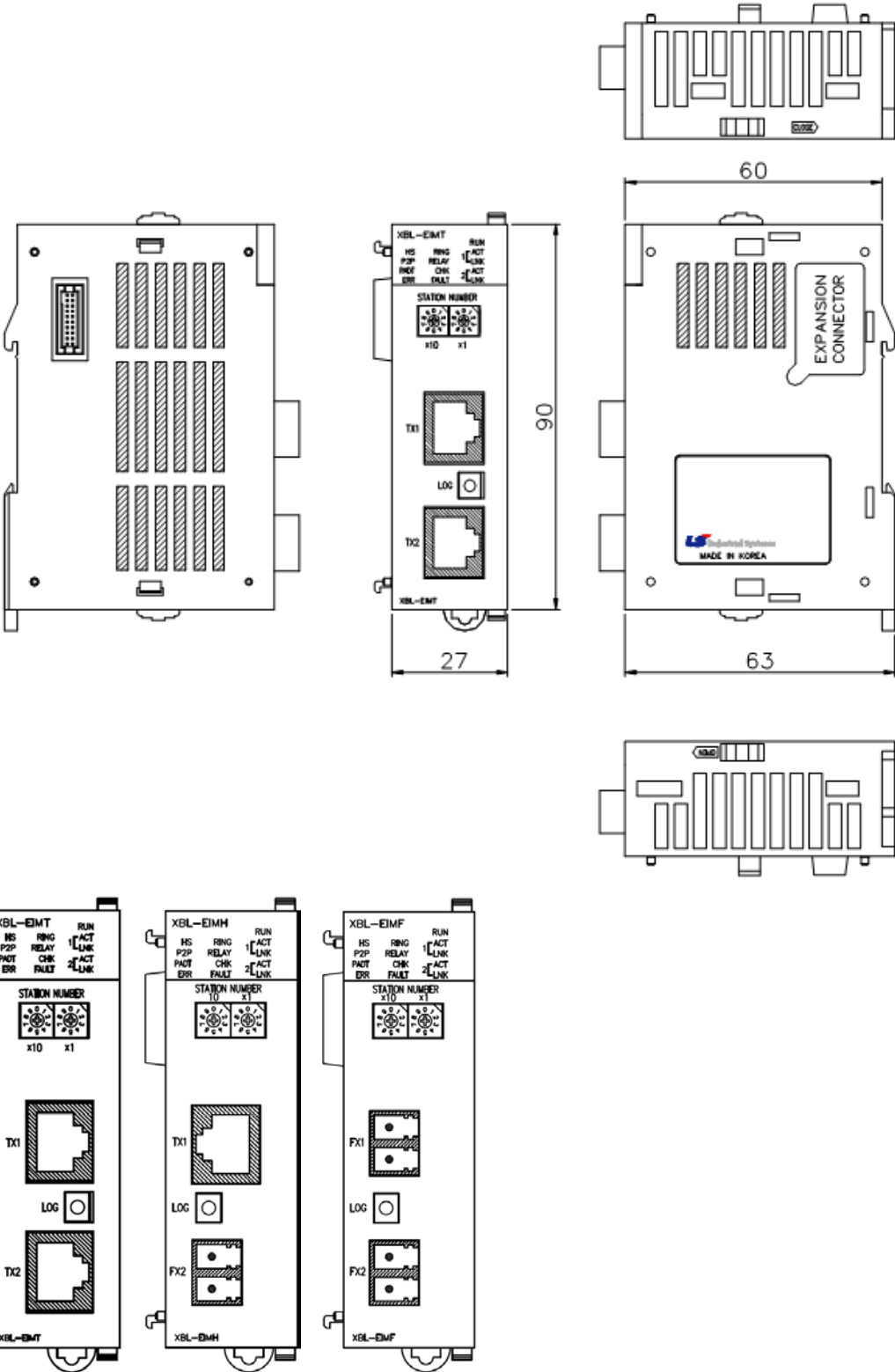

Appendix

• XOL-ES4T

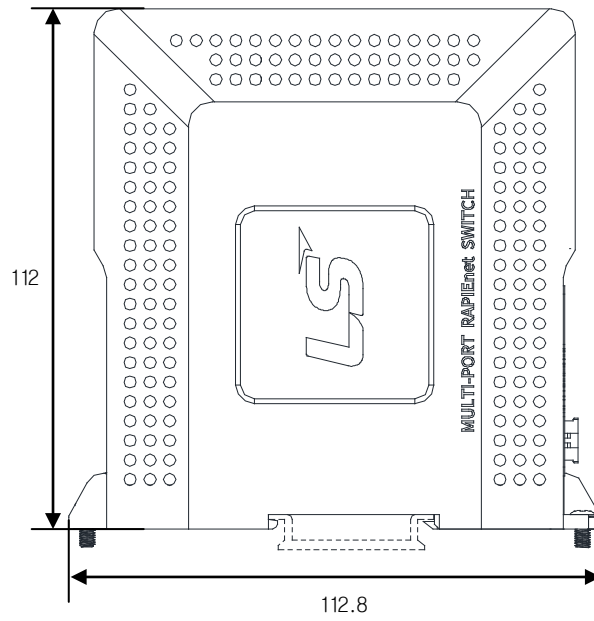
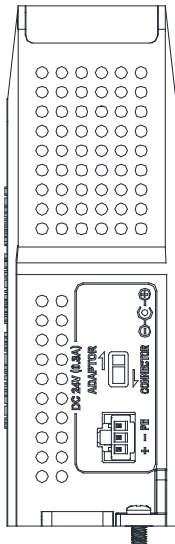
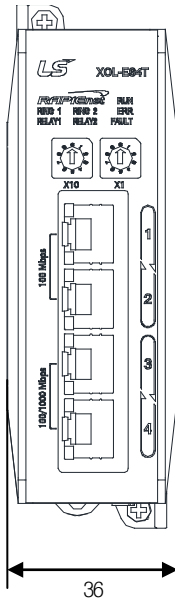

A.4 Troubleshooting

A.4.1 Hardware failure

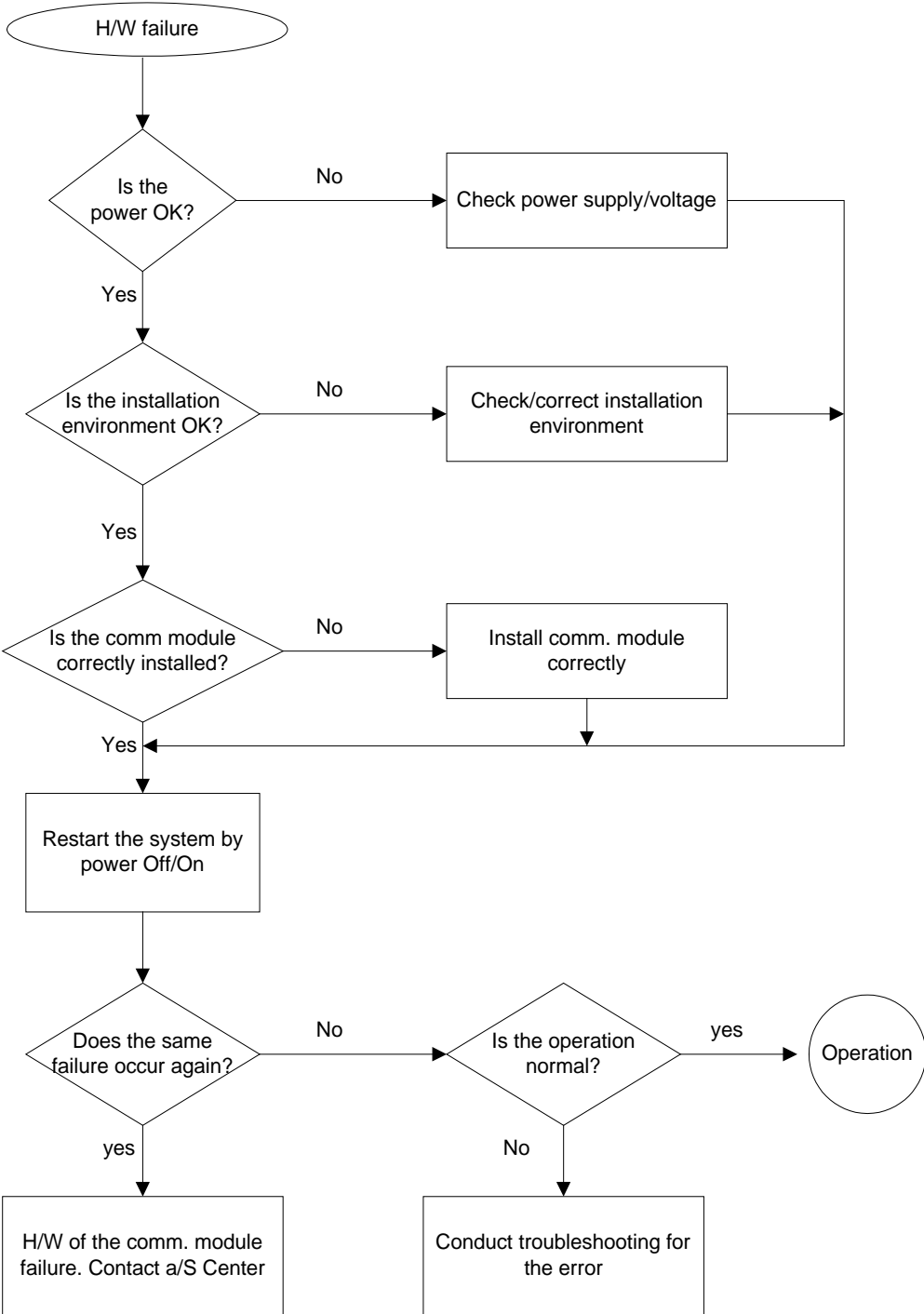

A.4.2 Interface failure

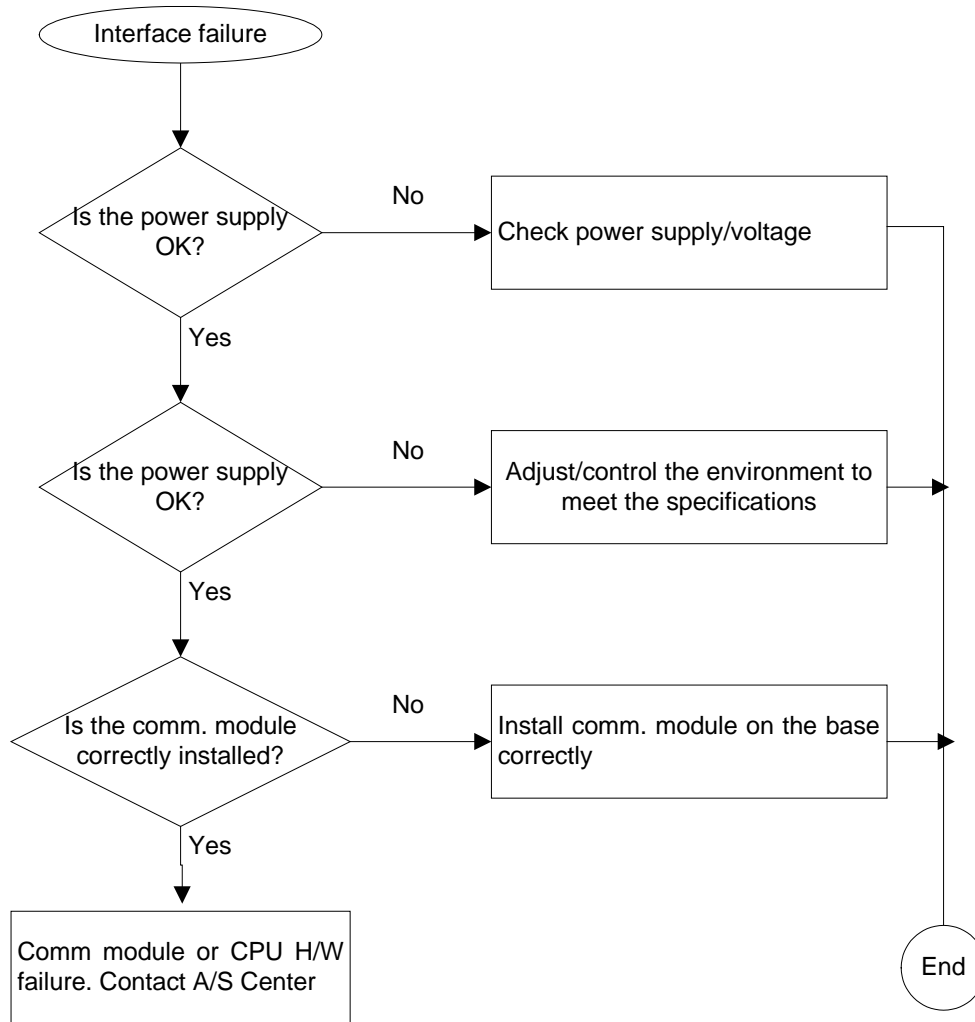

A.4.3 CPU and interface failure during operation

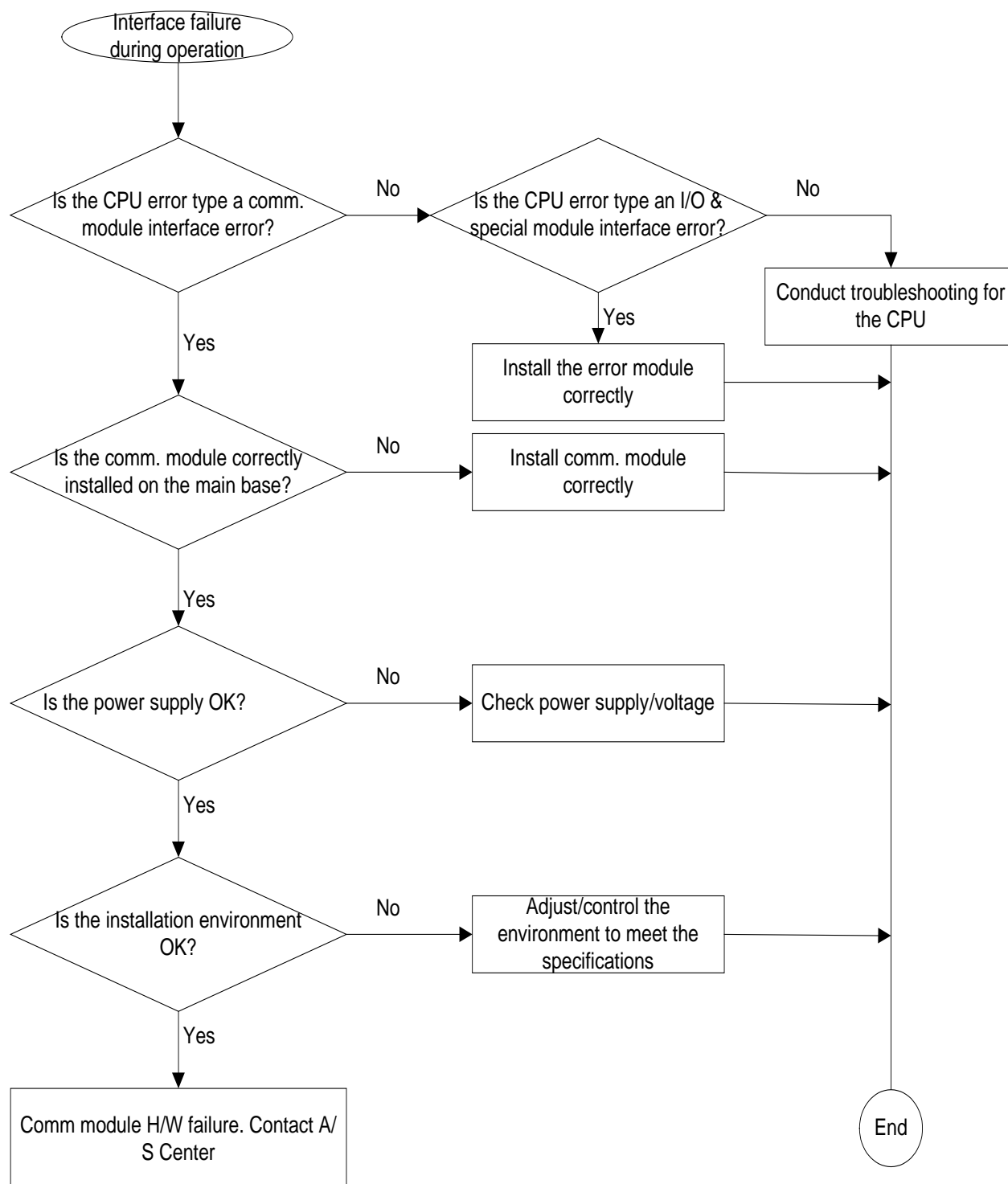

A.4.4 High-speed link parameter error

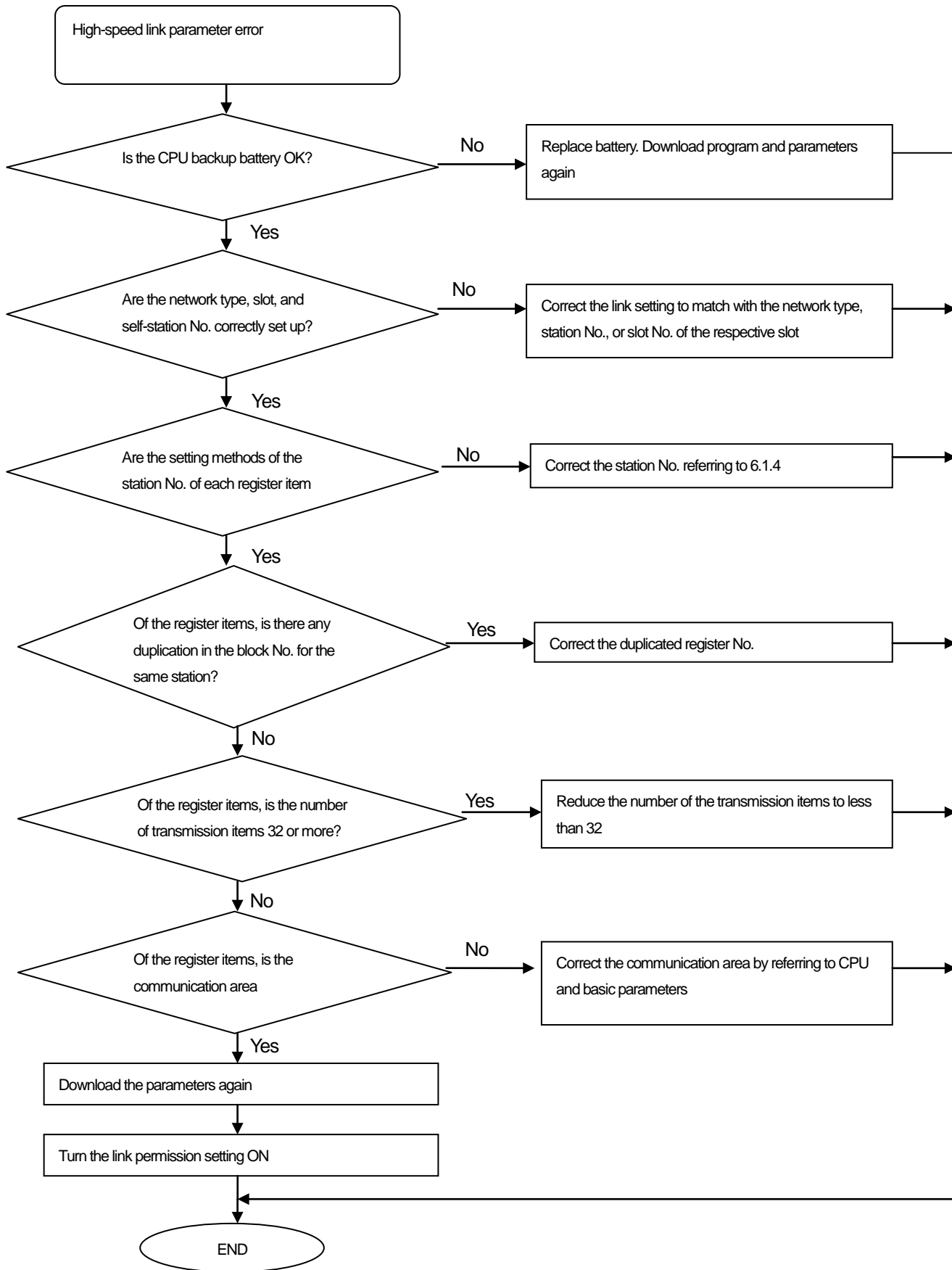

A.4.5 High-speed link operation failure

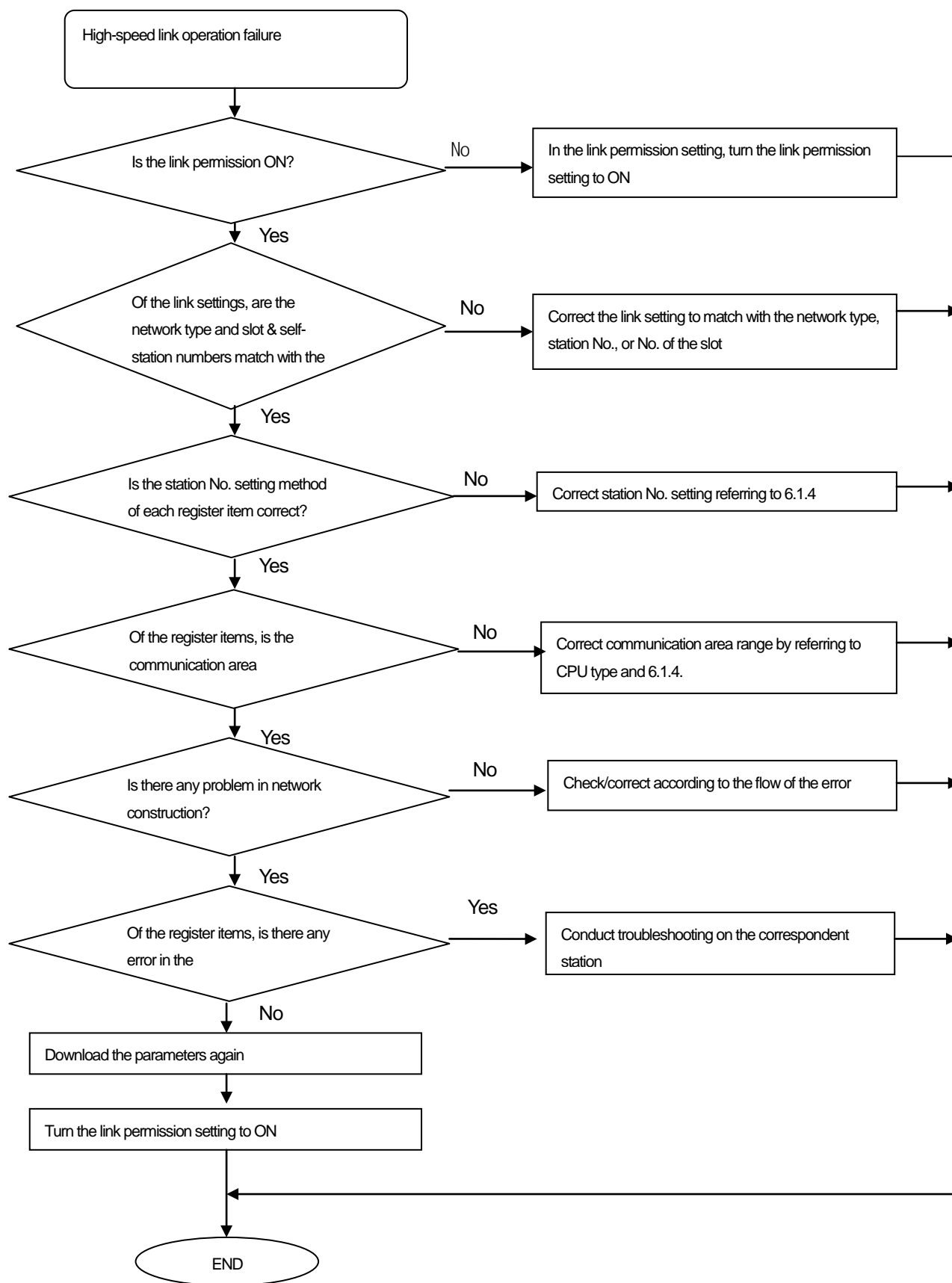

A.5 Performance Table

A.5.1 High-speed link performance table

When receiving maximum 200 words in 1 block of the RAPIEnet I/F Module, the maximum process time is 500 μ s.
 The maximum number of the blocks and time of allowable reception considering the CPU scan time by the period of high speed link transmission are as follows;

	High speed transmission link period of the module which will receive the data (ms)	Max. scan time of the CPU module (ms)	Max. No. of receiving blocks	Max. process time (ms)
1	5	3 max.	4	2
		5 over	No warranty	-
2	10	3 max.	8	4
		8 max.	4	2
		10 over	No warranty	-
3	20	3 max.	32	16
		8 max.	16	8
		18 max.	4	2
		20 over	No warranty	-
4	50	3 max.	64	32
		8 max.	32	16
		18 max.	16	8
		48 max.	8	4
		50 over	No warranty	-
5	100	3 max.	128	64
		8 max.	64	32
		18 max.	32	16
		48 max.	16	8
		98 max.	8	4
		100 over	No warranty	-
6	200	3 max.	128	64
		8 max.	128	64
		18 max.	64	32
		48 max.	16	8
		98 max.	8	4
		100 over	No warranty	-
7	500	3 max.	128	64
		8 max.	128	64
		18 max.	128	64
		48 max.	64	32
		98 max.	32	16
		198 max.	16	8
		498 max.	8	4
		500 over	No warranty	-
8	1s	3 max.	128	64
		8 max.	128	64
		18 max.	128	64
		48 max.	64	32
		98 max.	32	16
		198 max.	16	8
		498 max.	8	4
		500 over	No warranty	-

A.6 Error Code

A.6.1 P2P client error code

Error code is expressed as hexadecimal 2 byte. You can check the error at the frame monitor. If you see the error frame by ASCII, you can see the error frame as follows.

Code	Name	Description
H04	SVR_ADDR_OVERFLOW_ERR	Address exceeds the area
H05	SVR_DATA_VALUE_ERR	In case it is bit type and size is larger than 8 Fixed as 1 when setting through XG5000
H10	SVR_MAX_ESEND_SIZE_ERR	Data size exceeds 512 byte
H11	SVR_ADDR_DATA_TYPE_ERR	Invalid data type
H12	SVR_ADDR_DEV_TYPE_ERR	Invalid device
H13	SVR_MAX_BLOCK_ERR	Max. block excess error (when more than 80 blocks)
H15	P2P_LINK_TIMEOUT_ERR	No response during 5 sec after a P2P request at the main unit
H16	P2P_DEVIE_ERR	When there is error in making a P2P request frame at the main unit, it doesn't send a request frame
H03	P2P_VAR_COUNT_ERR	The number of variable of read request is different from the number of variable of response frame
H05	P2P_RESP_FUNC_ERR	Instruction of response frame is unknown
H0B	P2P_MAX_BLOCK_NO_ERR	P2P block ID is 32 or above
H0C	P2P_PARAM_DOWN_ERR	The request comes from a main unit before downloading parameter is complete
H0D	P2P_BLOCKID_ERR	Destination station number is set as more than 64 Destination station number is same as self station number
H0E	P2P_REQ_UNKNOWN_FUNC	Unknown request instruction
H27	P2P_REQ_UNKNOWN_NETSTATE	Network status is not determined whether it is Ring or Line.
H28	P2P_REQ_DUP_STATION	There is the duplicated station number in the network.
HFF	P2P_RUN_ERR	The request comes from a main unit when P2P is not normal
H3A	P2P_TIMEOUT_ERR	There is no response during 2.5 sec from server after P2P request at the module

A.6.2 Error Code of RAPIenet PC Card

Error types are displayed in hexadecimal error codes. Any error that takes place can be checked through return value of the user function

Code	Name	Detailed Description
0xFFFE	COMM_ERR_PCCARD_INIT_FAIL	PC Card initialization is failed
0xFFFD	COMM_ERR_STR_SIZE	The size of a wrong structure is inputted
0xFFFC	COMM_ERR_INV_SVC_CMD	Service command is inputted, which is not supported
0xFFFB	COMM_ERR_INV_SUB_CMD	Sub command is inputted, which is not supported
0xFFFA	COMM_ERR_INV_READ	Read is not supported
0xFF9	COMM_ERR_INV_WRITE	Write is not supported
0xFF8	COMM_ERR_INV_ALIGN	Alignment is not valid
0xFF7	COMM_ERR_INV_HANDLE	Handle is not valid
0xFF6	COMM_ERR_PCCARD_ACC_FAIL	Access to PC Card is failed
0xF00	COMM_ERR_UNKNOWN	
0X5001	HS_PMT_ERR_PERIOD	The sending period is not supported
0X5002	HS_PMT_ERR_INDXMODE	The index mode is not supported
0X5003	HS_PMT_ERR_STATNO	The station number is not supported
0X5004	HS_PMT_ERR_BLKID	The Block ID is not supported
0X5005	HS_PMT_ERR_INDNO	The index number is not supported
0X5006	HS_PMT_ERR_BLKSIZE	A wrong block size is specified
0X5007	HS_PMT_ERR_BLKCNT	A wrong block count is specified
0X5009	HS_PMT_ERR_BITDATA	Bit control parameter has something wrong
0X7000	P2P_ERR_MSG_FORMAT	Message format is wrong
0X7001	P2P_ERR_BUFF_FULL	No space available to save message
0X7002	P2P_ERR_SMALL_BUFF	The size to read is bigger than the user's buffer size
0X7010	P2P_ERR_SND_FAIL	P2P request sending is failed
0X7011	P2P_ERR_INVOKEID_OVRR	Previous Invoke ID is not completed
0X7012	P2P_ERR_TIMEOUT	No response from the counterpart
0X7013	P2P_ERR_VAR_NAME	Wrong variable

A.7 User Function of RAPIEnet PC Card

The User functions on RAPIEnet PC Card may provide information such as their return values, parameters and types differently depending on the user tools.

The User functions provides the main functions related to setting connection to RAPIEnet PC Card or sending/receiving actions, the control functions controlling RAPIEnet PC Card and the diagnosis functions that diagnose the state of RAPIEnet PC Card.

A.7.1 Main Function

Function Name	Description	Return Value	Parameter
InitDevice	Set to connect RAPIEnet PC Card	Accept/Reject	Process Instance
			Mounted RAPIEnet PC Card Handle
			The number of the mounted RAPIEnet PC Card
ReadDevice	Read and save the designated area of the counterpart station	Accept/Reject	The currently selected RAPIEnet PC Card Handle
			Station number information (High-speed link is ignored)
			Device information(High-speed link: HS, P2P: M, D ...)
WriteDevice	Save the data of My station's designated area in the counterpart station's defined area	Accept/Reject	Offset information(The starting point of memory to Read and Write)
			Size (Size of data to Read and Write)
			Saving Buffer
ReadBit	Read and save the designated area of the counterpart station	Accept/Reject	Station number information of the currently selected RAPIEnet PC Card Handle
			Station number information (High-speed link is ignored)
			Device information(High-speed link: HS, P2P: M, D ...)
WriteBit	Save the data of My station's designated area in the counterpart station's defined area	Accept/Reject	Offset information The starting point of memory to Read and Write)
			Size (Location for Bit Read and Write)
			Saving Buffer

A.7.2 Control Function

Function Name	Description	Return Value	Parameter
CtrlGetHeartbeat	Function to get Heartbeat	Accept/Reject	The currently selected RAPIEnet PC Card Handle
			Saving Buffer
CtrlGetStationNumber	Function to get station number	Accept/Reject	The currently selected RAPIEnet PC Card Handle
			Saving Buffer
CtrlGetMACAddress	Function to get MAC ADDRESS	Accept/Reject	The currently selected RAPIEnet PC Card Handle
			Saving Buffer
CtrlGetHSEnable	Function to get high-speed link Enable/Disalbe	Accept/Reject	The currently selected RAPIEnet PC Card Handle
			Saving Buffer
CtrlSetHSEnalbe	Function to set high-speed link Enable	Accept/Reject	The currently selected RAPIEnet PC Card Handle
			Saving Buffer
CtrlSetHSDisable	Function to set high-speed link Disable	Accept/Reject	The currently selected RAPIEnet PC Card Handle
			Saving Buffer
CtrlSetReset	Function to reset RAPIEnet PC Card	Accept/Reject	The currently selected RAPIEnet PC Card Handle

A.7.3 Diagnosis Function

Function Name	Description	Return Value	Parameter
DiagGetHWState	Function to get hardware state	Accept/Reject	The currently selected RAPIEnet PC Card Handle Saving Buffer
DiagGetHWVer	Function to get hardware version	Accept/Reject	The currently selected RAPIEnet PC Card Handle Saving Buffer
DiagGetOSVer	Function to get OS version	Accept/Reject	The currently selected RAPIEnet PC Card Handle Saving Buffer
DiagGetRunMode	Function to get OS state	Accept/Reject	The currently selected RAPIEnet PC Card Handle Saving Buffer
DiagGetOptionType	Function to get link kind	Accept/Reject	The currently selected RAPIEnet PC Card Handle Saving Buffer
DiagGetNodeStatus	Function to get network state of node	Accept/Reject	The currently selected RAPIEnet PC Card Handle Saving Buffer
DiagGetP0Available	Function to display the connection state of Port 0	Accept/Reject	The currently selected RAPIEnet PC Card Handle Saving Buffer
DiagGetP1Available	Function to display the connection state of Port 1	Accept/Reject	The currently selected RAPIEnet PC Card Handle Saving Buffer
DiagGetNodesInNetwork	Function to get node information	Accept/Reject	The currently selected RAPIEnet PC Card Handle Saving Buffer
DiagGetP0TxCnt	Function to get frame number sent by port	Accept/Reject	The currently selected RAPIEnet PC Card Handle Saving Buffer
DiagGetP0TxAll	Function to get total frame number sent by port	Accept/Reject	The currently selected RAPIEnet PC Card Handle Saving Buffer
DiagGetP0RxCnt	Function to get frame number received from port	Accept/Reject	The currently selected RAPIEnet PC Card Handle Saving Buffer
DiagGetP0RxAll	Function to get total frame number received from port	Accept/Reject	The currently selected RAPIEnet PC Card Handle Saving Buffer
DiagGetP0RelayCnt	Function to get frame number relayed from port	Accept/Reject	The currently selected RAPIEnet PC Card Handle Saving Buffer
DiagGetP0RelayAll	Function to get total frame number relayed from port	Accept/Reject	The currently selected RAPIEnet PC Card Handle Saving Buffer
DiagGetP1TxCnt	Function to get frame number sent by Port 1	Accept/Reject	The currently selected RAPIEnet PC Card Handle Saving Buffer
DiagGetP1TxAll	Function to get total frame number sent Port 1	Accept/Reject	The currently selected RAPIEnet PC Card Handle Saving Buffer
DiagGetP1RxCnt	Function to get frame number received from Port 1	Accept/Reject	The currently selected RAPIEnet PC Card Handle Saving Buffer
DiagGetP1RxAll	Function to get total frame number received from Port 1	Accept/Reject	The currently selected RAPIEnet PC Card Handle Saving Buffer
DiagGetP1RelayCnt	Function to get frame number relayed from Port 1	Accept/Reject	The currently selected RAPIEnet PC Card Handle Saving Buffer
DiagGetP1RelayAll	Function to get total frame number relayed from Port 1	Accept/Reject	The currently selected RAPIEnet PC Card Handle Saving Buffer
DiagGetTxLCastCnt	Function to get the sent LCAST frame number per 1 second	Accept/Reject	The currently selected RAPIEnet PC Card Handle Saving Buffer

DiagGetTxMcastCnt	Function to get the sent MCAST frame number per 1 second	Accept/Reject	The currently selected RAPIEnet PC Card Handle Saving Buffer
DiagGetTxGcastCnt	Function to get the sent GCAST frame number per 1 second	Accept/Reject	The currently selected RAPIEnet PC Card Handle Saving Buffer
DiagGetTxBcastCnt	Function to get the sent BCAST frame number per 1 second	Accept/Reject	The currently selected RAPIEnet PC Card Handle Saving Buffer
DiagGetTxUcastCnt	Function to get the sent UCAST frame number per 1 second	Accept/Reject	The currently selected RAPIEnet PC Card Handle Saving Buffer
DiagGetRxLcastCnt	Function to get the received LCAST frame number per 1 second	Accept/Reject	The currently selected RAPIEnet PC Card Handle Saving Buffer
DiagGetRxMcastCnt	Function to get the received MCAST frame number per 1 second	Accept/Reject	The currently selected RAPIEnet PC Card Handle Saving Buffer
DiagGetRxGcastCnt	Function to get the received GCAST frame number per 1 second	Accept/Reject	The currently selected RAPIEnet PC Card Handle Saving Buffer
DiagGetRxBcastCnt	Function to get the received BCAST frame number per 1 second	Accept/Reject	The currently selected RAPIEnet PC Card Handle Saving Buffer
DiagGetRxUcastCnt	Function to get the received UCAST frame number per 1 second	Accept/Reject	The currently selected RAPIEnet PC Card Handle Saving Buffer
DiagGetTxCnt	Function to get the sent frame number per second	Accept/Reject	The currently selected RAPIEnet PC Card Handle Saving Buffer
DiagGetRxCnt	Function to get the received frame number per second	Accept/Reject	The currently selected RAPIEnet PC Card Handle Saving Buffer
DiagGetTxRxCnt	Function to get the sent/received frame number per second	Accept/Reject	The currently selected RAPIEnet PC Card Handle Saving Buffer

Warranty

- 1. Terms of warranty
LSIS provides an 18-month warranty starting from the date of production.

- 2. Range of warranty
For problems within the terms of the warranty, LSIS will replace the entire PLC or repair the defective parts free of charge except for the following cases.
 - (1) Problems caused by improper conditions, environment or treatment.
 - (2) Problems caused by external devices.
 - (3) Problems caused by the user remodeling or repairing the PLC.
 - (4) Problems caused by improper use of the product.
 - (5) Problems caused by circumstances where the expectations exceed that of the science and technology level when LSIS produced the product.
 - (6) Problems caused by natural disaster.

- 3. This warranty is limited to the PLC itself only. It is not valid for the system which the PLC is attached to.

Environmental Policy

LSIS Co., Ltd supports and observes the environmental policy as below.

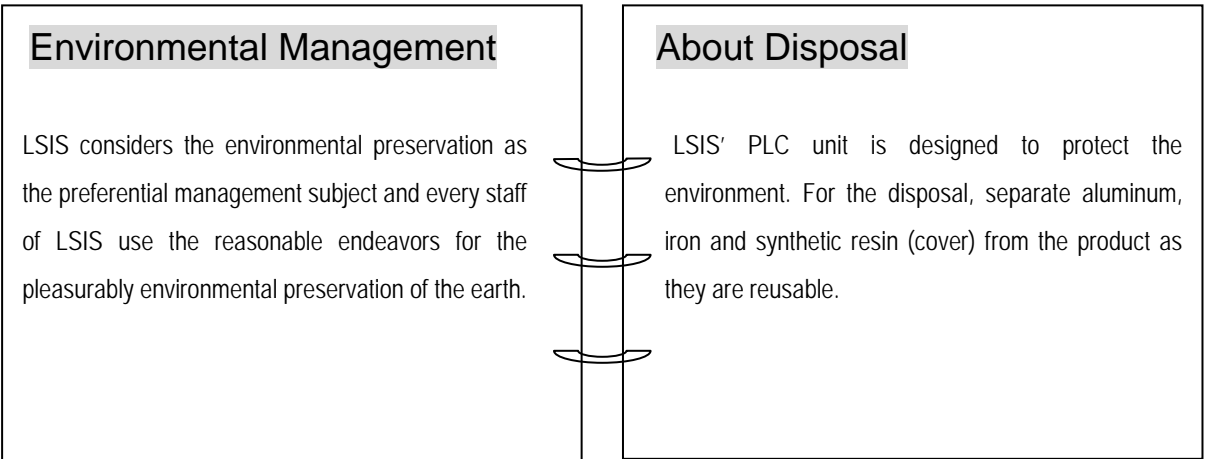



LSIS values every single customers.
Quality and service come first at LSIS.
Always at your service, standing for our customers.

<http://eng.lsis.biz>

LSIS

10310000889

■ **HEAD OFFICE**

LS Tower, 127, LS-ro, Dongan-gu, Anyang-si, Gyeonggi-do, 431-848, Korea
 Tel : (82-2)2034-4870/Fax : 82-2-2034-4648 e-mail : cshwang@lsis.biz

■ **LSIS Tokyo Office _ Tokyo, Japan**

Address: 16FL, Higashi-Kan, Akasaka Twin Tower 17-22,
 Akasaka, Monato-ku Tokyo 107-8470, Japan
 Tel : 81-3-3582-9128/Fax : 81-3-3582-2667 e-mail : jschuna@lsis.biz

■ **LSIS (ME) FZE _ Dubai, U.A.E.**

Address : Jafza View Tower Lob 19, Room 205 Along Sheikh Zayed
 Road Jebel Aali Free Zone Dubai, United Arab Emirates
 Tel : 971-4-886-5360/Fax : 971-4-886-5361 e-mail : jungyongl@lsis.biz

■ **LSIS Shanghai Office _ Shanghai, China**

Address : Room E-G, 12FL Hiamin Empire Plaza, No.726, West,
 Yan'an Road Shanghai 200050, P.R. China e-mail : liyong@lsis.com.cn
 Tel : 86-21-5237-9977(609)/Fax : 89-21-5237-7189

■ **LSIS Beijing Office _ Beijing, China**

Address : B-Tower 17FL, Beijing Global Trade Center B/D, No. 36,
 East Beisanhuan-Road, DongCheng-District, Beijing 100013, P.R. China
 Tel : 86-10-5825-6027(666)/Fax : 86-10-5825-6028 e-mail : xunmi@lsis.com.cn

■ **LSIS Guangzhou Office _ Guangzhou, China**

Address : Room 1403.14FL, New Poly Tower,
 2 Zhongshan Liu Road, Guangzhou, P.R. China
 Tel : 86-20-8328-6754/Fax : 86-20-8326-6287 e-mail : chenxs@lsis.com.cn

■ **LSIS Chengdu Office _ Chengdu, China**

Address : 12FL, Guodong Buiding, No.52 Jindun
 Road Chengdu.610041, P.R. China
 Tel : 86-28-8612-9151(9226)/Fax : 86-28-8612-9236 e-mail : comysb@lsis.biz

■ **LSIS Qingdao Office _ Qingdao, China**

Address : YinHe Bldg, 402 Room No. 2P Shandong Road,
 Qingdao-City, Shandong-province 266071, P.R. China
 Tel : 86-532-8501-6068/Fax : 86-532-8501-6057 e-mail : wangzy@lsis.com.cn

■ **LSIS Europe B.V. , Netherlands**

Address : 1st. Floor, Tupolevlaan 48, 1119NZ, Schiphol-Rijk, The Netherlands
 Tel : +31 (0)20 654 1420/Fax : +31 (0)20 654 1429 e-mail : junshickp@lsis.biz

■ **Wuxi LSIS Co., Ltd _ Wuxi, China**

Address : 102-A, National High & New Tech Industrial Development Area,
 Wuxi, Jiangsu, 214028, P.R. China
 Tel : 86-510-8534-6666/Fax : 86-510-8534-4078 e-mail : caidx@lsis.com.cn

■ **Dalian LSIS Co., Ltd. _ Dalian, China**

Address : No. 15, Liaohexi 3-Road, Economic and Technical Development zone,
 Dalian 116600, China
 Tel : 86-411-273-7777/Fax : 86-411-8730-7560 e-mail : cuibx@lsis.com.cn

■ **Homepage**

<http://eng.lsis.biz>

※ LSIS constantly endeavors to improve its product so that information in this manual is subject to change without notice.

© LSIS Co., Ltd 2013 All Rights Reserved.

2016. 12