

DPR User Manual

LG Digital Protection Relays



DPR User Manual

LG Digital Protection Relays



Contents

General descriptions	3
Features	3
Additional functions	4
Environmental characteristics	6
1. Overcurrent Relay for Phase and Earth Faults (OCR & OCGR)	
DPR-011, DPR-111	
1.1 Features and specifications	7
1.2 Block diagram	8
1.3 Application	9
1.4 Wiring	11
1.5 Output contacts	14
1.6 Front face configuration	15
1.7 Operation manual	16
2. Selective Ground Relay(SGR: Selective Earth Fault Protection)	
DPR-211	
2.1 Features and specifications	36
2.2 Block diagram	37
2.3 Application	38
2.4 Wiring	38
2.5 Output contacts	39
2.6 Front face configuration	40
2.7 Operation manual	41
3. Under and Overvoltage Relay (UVR & OVR)	
DPR-311, DPR-411	
3.1 Features and specifications	52
3.2 Block diagram	53
3.3 Application	54
3.4 Wiring	55
3.5 Output contacts	57
3.6 Front face configuration	58
3.7 Operation manual	59

4. Over Voltage Ground Relay(OVGR : Earth Fault Overvoltage Protection)	
DPR-511	
4.1 Features and specifications	78
4.2 Block diagram	79
4.3 Application	80
4.4 Wiring	80
4.5 Output contacts	81
4.6 Front face configuration	82
4.7 Operation manual	83
5. Characteristic curves and data	95
6. Dimensions and installation	103
7. Warnings	104
8. Ordering information	104

General descriptions

LG Digital Protection Relay, DPR is designed to realize the several features that the conventional analog relays were not able to offer. Those are complex protection algorithm, accurate measuring, convenience in operation, lower power consumption, self-diagnostics, fault recording, option of output contacts operation and compact physical size. In addition it provides 250kbps communication speed that seems to be the highest among the competitors.

LG DPR is divided into six(6) types by protection functions as follows.

	Type	Functions
DPR	DPR-011	OCR
	DPR-111	OCR/OCGR
	DPR-211	SGR
	DPR-311	Option between OVR and UVR
	DPR-411	OVR and UVR
	DPR-511	OVGR

Contact LG in case you look for the protection relay that have all functions above in a product. That's LG GIPAM(Digital Integrated Protection & Monitoring Equipment).

Features

Compact design

- 124mm (width), 177m (Height), 243mm (Depth)

Simple operation and setting

- All parameter setting is available by operating the front key-buttons

Back-lit LCD display

- Back-lit LCD display provides high visibility
- Easy checking for a cause of fault or setting status is available with various indication function
- All trips lead to LCD flickering.

Current and time adjustable

- Minute setting steps for current and time are appropriate for network protection

Self-supervision function with auto-diagnostics

- Power, A/D converting, CPU watchdog, Internal memory, EEPROM and calibration checking, etc.

The use of output contacts are adjustable.

- Various setting for output contacts of trips or alarms is available

Fault recording function

- When cable fault these fault curves are recorded into EEPROM by 10 cycles

Sequence of Event function(S.O.E /Optional)

- Many events including relay element operation, a cause of fault, data adjustment can be provided to higher system.

Various communication network

- I-NET exclusive communication and MODBUS communication(optional)

EMC/EMI Test certified

Additional Functions

Self-supervision with auto-diagnostics

High reliability of relay will be provided by various self-diagnostics function.

When errors occurs it will be displayed "Error No." at LCD display window, then the front ALARM LED lights on and LCD display window flickers on also.

At the same time ALARM Relay(Sys Fail) will be output.

1. Internal ROM check : "Error 1"
2. Internal RAM check : "Error 2"
3. A/D converter check : "Error 3"
4. CPU watchdog check : "Error 4"
5. Power supply check : "Error 5"
6. EEPROM(Backup memory) : check : "Error 6"
7. Calibration check : "Error 7"

If it happens self-diagnostics error the relay is not operated until any error element elimination.

Fault records

1. The fault curve are recorded into EEPROM when line fault happens, which will provide fast and correct grasping for the cause of fault.
2. Storage the sample value of each phase with 10 cycles before and after of fault
 - 5 cycles before the fault
 - 5 cycles after the fault
 - 8 samples for a cycle
3. Fault Recording information is available for ascertaining them via communications.

Sequence of Event(S.O.E)

Many events including relay element operation, a cause of fault, data adjustment can be provided to higher system.

1. Kinds of event
 - The cause for relay operation(trip)
 - The correction for data of relays
 - Error occurrence for auto-diagnostics
 - Relay resetting
2. Twenty events are stored in a buffer with maximum.

Communication specification

I-NET communication

High speed, high reliability of serial communication used the Custom LSI (GC829016) developed by LGIS will be provided.

- 1) Data rate : 250kbps
- 2) Cable length : 1000m (max.)
- 3) Insulation : Pulse transformer
- 4) Connection : 4 wires Multidrop
- 5) Signal modulation : Bipolar modulation
- 6) Connectable quantity : Available for linkage up to max. 255 units, max. 20units per a GMPC (a protocol converter)
- 7) Address : Parameter setting from 1 to 255
- 8) Communication cable : Low Capacitance LAN Interface Cable
 - Spec : LIREV AMESB 22AWG 2 -pair(1/0.643)
 - Impedance : 10MHz, 120()
 - Termination : Please use it by connecting 2 resistors with each end of cable

Environmental Characteristics

Dielectric withstand	IEC 255-5 KEMC 1120	2kV rms. for 1 minute between all case terminals connected together and the case earth. 2kV rms. for 1 minute between all terminals of independent circuits with terminals and each independent circuit connected together 1kV rms. for 1 minute between each terminals of open contact circuits
High voltage impulse	IEC 255-5 KEMC 1120	5kV peak, 1.2 x 50 μ s, between all terminals connected together and case earth. 5kV peak, 1.2 x 50 μ s, between mutual PT/CT circuits 5kV peak, 1.2 x 50 μ s, between PT/CT circuits and control circuits 3kV peak, 1.2 x 50 μ s, between mutual control circuits 3kV peak, 1.2 x 50 μ s, between all terminals of PT/CT circuits 3kV peak, 1.2 x 50 μ s, between all terminals of control power supply circuits
Insulation resistance	IEC 255-5 KEMC 1120	DC 500V 10M Ω and over between all case terminals connected together and the case earth. DC 500V 5M Ω and over between all terminals of independent circuits with terminals and each independent circuit connected together DC 500V 5M Ω and over between each terminals of open contact circuits
Overload capacity	KEMC 1120 JEC 2500 KEMC 1120	Current circuit : $I_n \times 2$ for 3 hours(2 times by 1 minute interval) $I_n \times 20$ for 2 seconds $I_n \times 40$ for 1 second Voltage circuit : $V_n \times 1.15$ for 3 hours(1 time)
High frequency disturbance	IEC 255-22-1 Class III	2.5kV peak between independent circuits and case. 1.0kV peak across terminals of the same circuit
Fast transient disturbance	IEC 255-22-4 Class IV	4kV applied directly to power input 2kV applied to other inputs
Electrostatic discharge (ESD)	IEC 255-22-2 Class III	8kV discharge in air with cover in place 6kV point contact discharge with cover removed
RFI	KEMC 1120	Making a wave by accessing to the edge of relay with 5W Transceiver(150MHz, 400MHz)
EMI	EN 50081-2 Class II	AC power : 0.15~0.50MHz, standard 79dB, average 66dB 0.50~30MHz, standard 73dB, average 60dB
Operating temperature	IEC 68-2-1	-10 ~ 55
Storage temperature	IEC 68-2-2	-20 ~ 70
Humidity	IEC 68-2-3	56 days at 93% RH and +40
Shock	IEC 255-21-2 Class III KEMC 1120	30g, 3times/dir.
Vibration	KEMC 1120	30Hz, 0.4mm vibration applied for 600 seconds
Enclosure protection	IEC 529	IP 50(dust protected)

1. Overcurrent Relay for Phase and Earth Faults (OCR & OCGR)

1.1 Features and specifications

Self-diagnostics	Standard inverse time
Fault recording	Very inverse time
Sequence of Event(S.O.E)	Extremely inverse time
High speed serial data communication	Long inverse time
International standard applied	Definite time
- IEC 255, IEC 1000-4, KEMC 1120	

Type designation			DPR-011	DPR-111
ANSI code			50/51 x 3	50/51 x 3 50/51N x 1
Ratings	Current (In)		5A	
	Frequency (fn)		50/60Hz	
	Control power (Vx)		DC 110/125V (DC 85~150V)	
	Input burdens		0.5VA and below	
Relay elements			3 phase overcurrent protection (OCR)	3 phase overcurrent protection (OCR) Earth fault overcurrent protection (OCGR)
Setting range	Time delayed settings	Phase	1~16A/0.5A (20~320%)	
		Earth	0.2~2.5A/0.1A (4~50%)	
	Instantaneous settings	Phase	10~160A/5A (200~3200%),Lock	
		Earth	2.5~40A/2.5A (50~800%),Lock	
Operating time	Time delayed element	Inverse	Standard Inverse, Very Inverse, Extremely Inverse, Long Inverse 0.05~1second in a 0.01 step	
		Definite	0.1~10seconds in a 0.1 step	
	Instantaneous element	Definite	Within 35msec	
Ancillary function			Self-diagnostics, Fault records, Sequence of Event (S.O.E)	
Communication mode			I-NET	
Display			Back-lit LCD (Dot Matrix)	
Output contacts	Switching capacity		Make 10A/250Vac, 0.5sec, Resistive Load Break 1A/250Vac 0.1PF	
	Constitution (7EA)		Trip Relay 2a, 1250VA and over Alarm Relay 4a System Fail Relay 1a	
	Type	at Trip operation self-diagnostics error at Normal	Trip Relay + Trip LED + Alarm Relay System Fail Relay+Alarm LED RUN LED	
Insulation Resistance			DC 500V 100MΩ and over	
Dielectric withstand			2kV (1kV) rms. and over for 1 minute	
High Voltage Impulse			5kV (3kV) peak and over applied for 1.2x50 μs	
Overload capacity	Current circuit		Rated current (In) x 2 for 3 hours Rated current (In) x 20 for 2 seconds Rated current (In) x 40 for 1 second	
	Voltage circuit		Rated voltage (Vn) x 1.15 for 3 hours	
Temperature	Operating		-10 ~ 55	
	Storage		-20 ~ 70	
Humidity			80% RH (non-condensing)	
Applicable standard			IEC 255, IEC1000-4, KEMC 1120	
Weight			3.2kg	
Dimension			124mm (width), 177mm (height), 243mm (depth)	

1.2 Block diagram

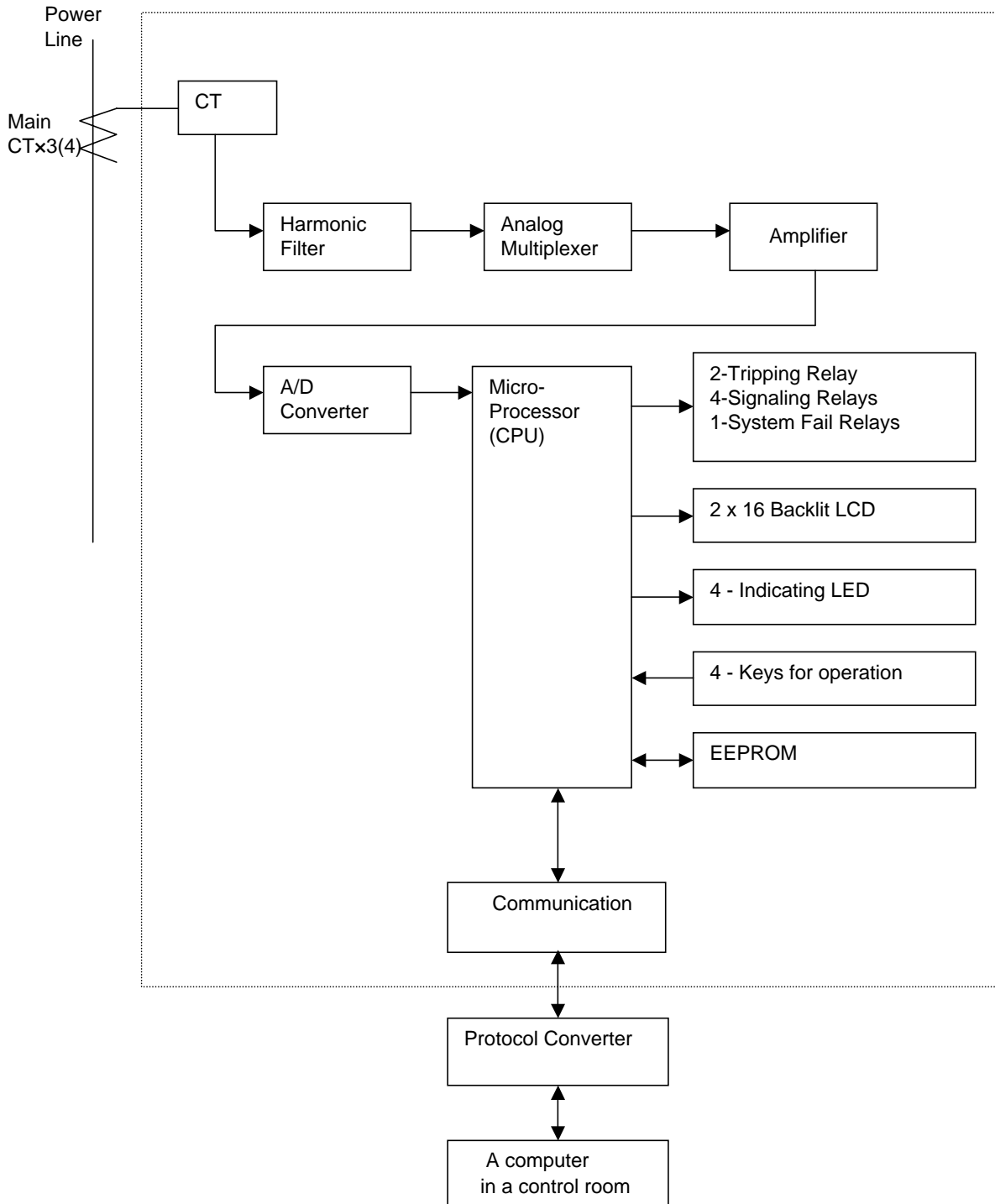

1.3 Application

Feeder Protection

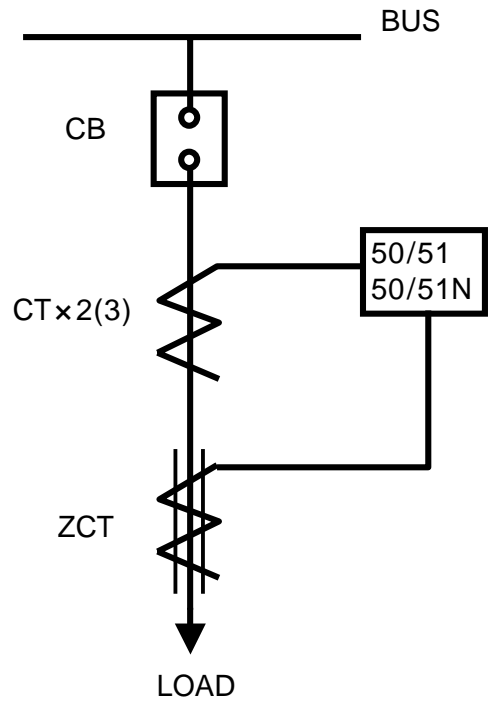
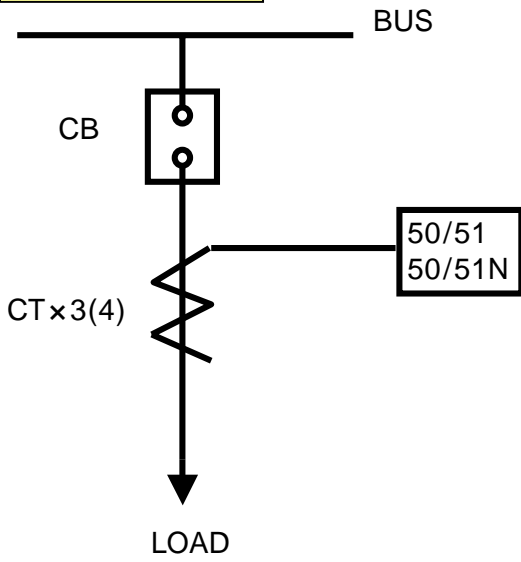

Transformer

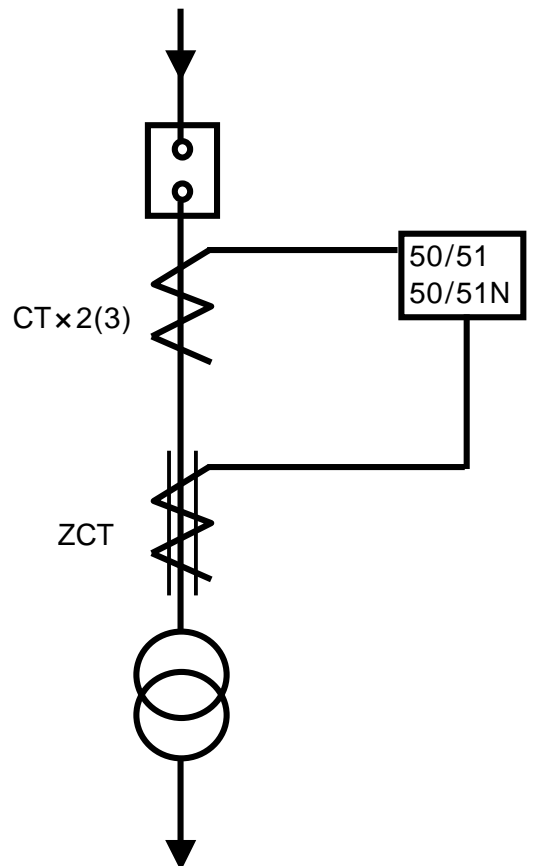
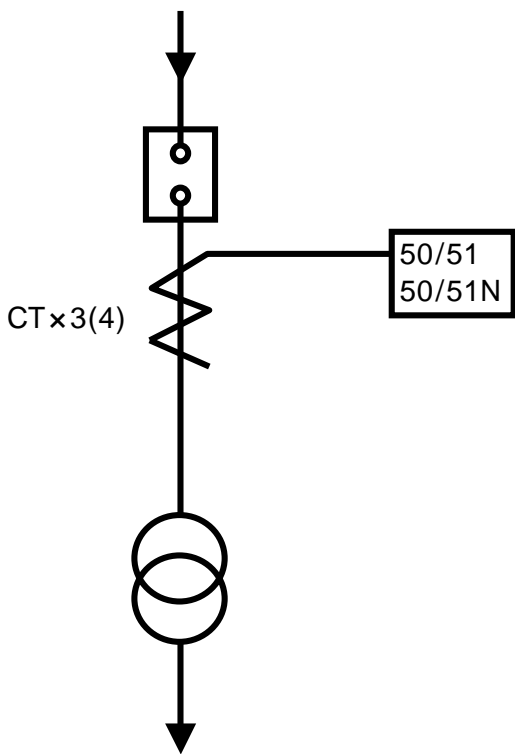

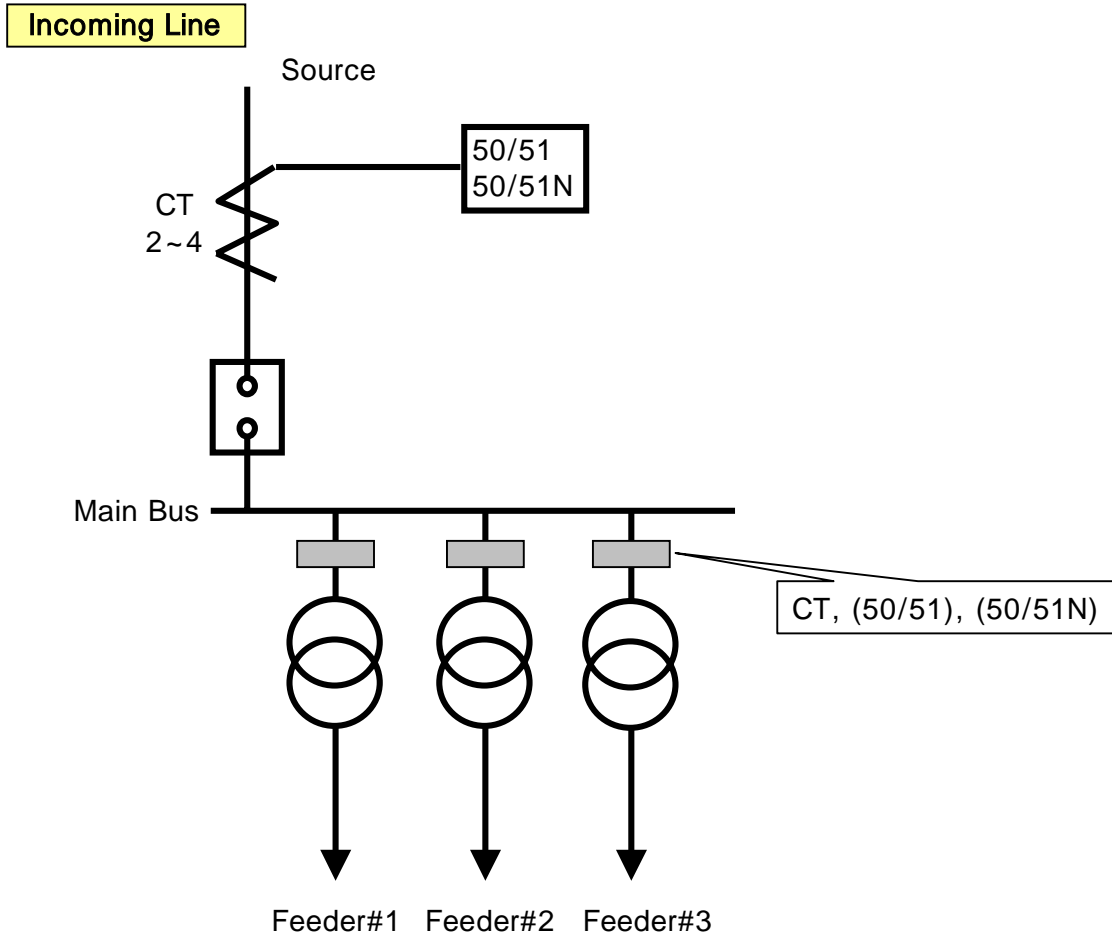
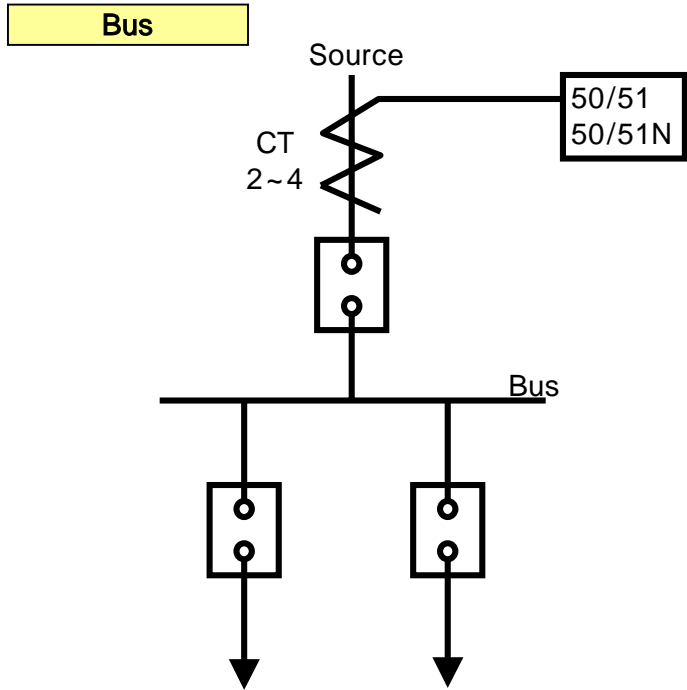

1.4 Wiring

Single phase three wire(2CT) system

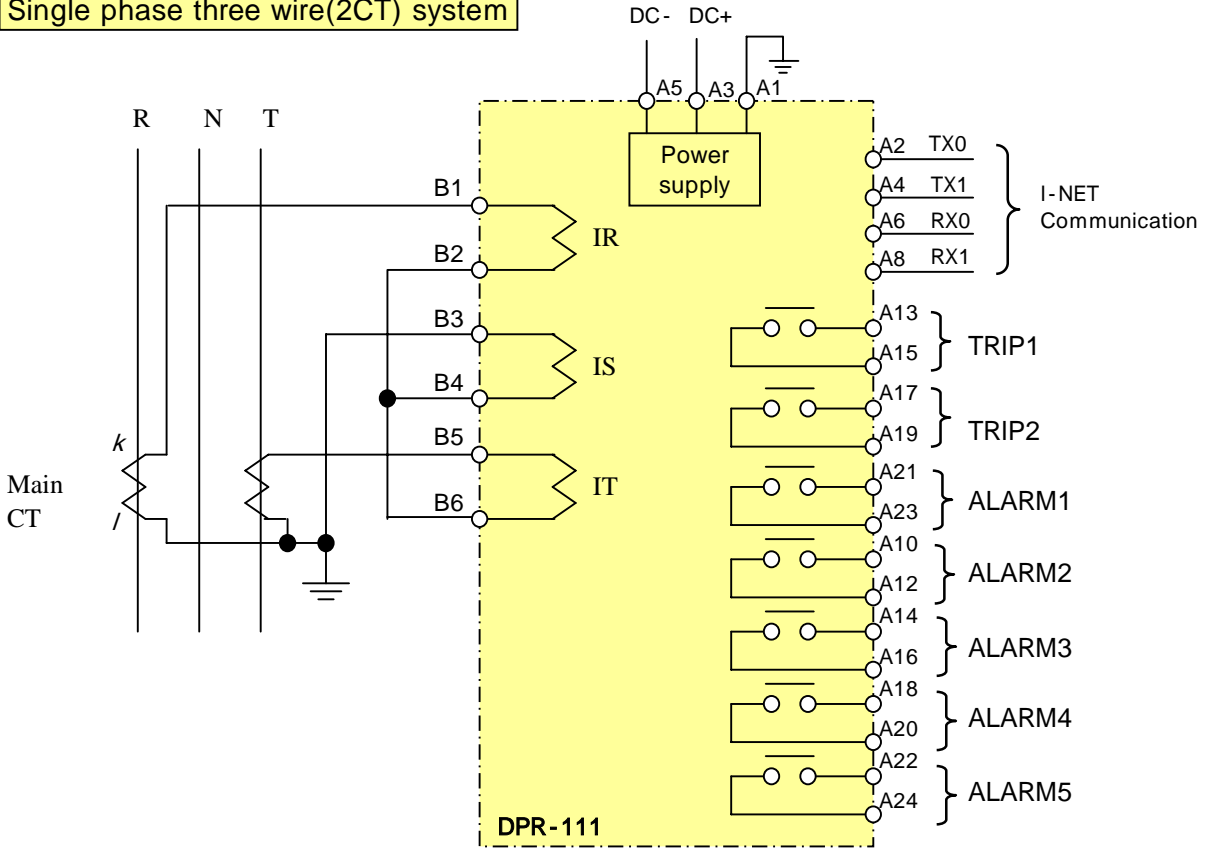

Three phase three wire(2CT) system

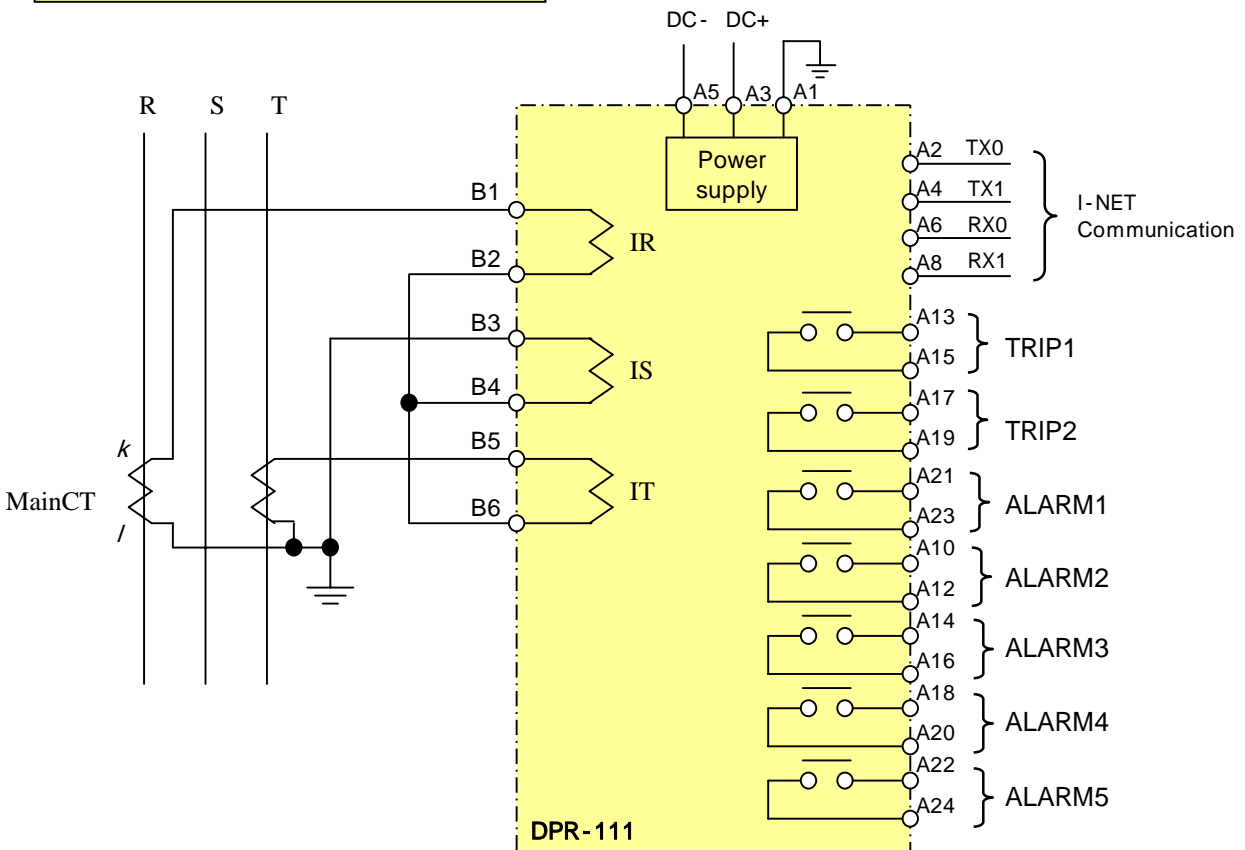

Three phase three wire(3CT) system

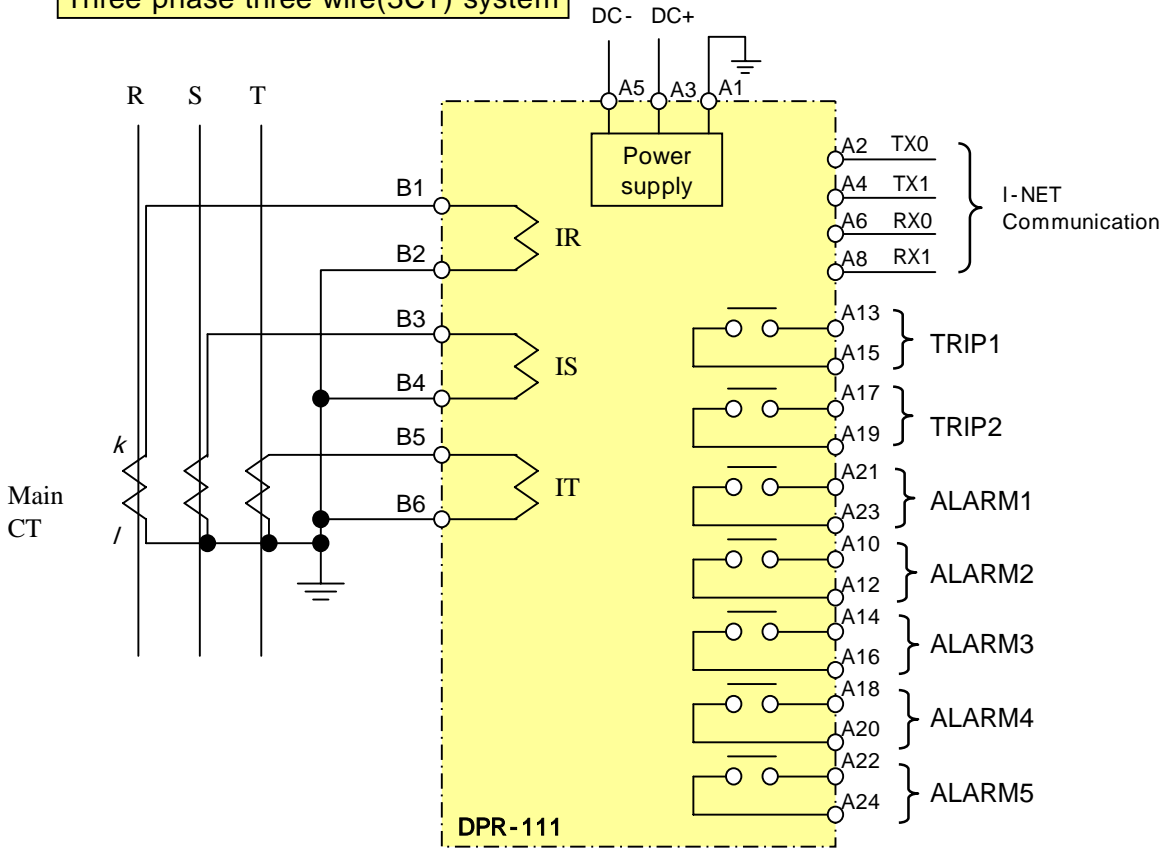

Three phase four wire(3CT) system

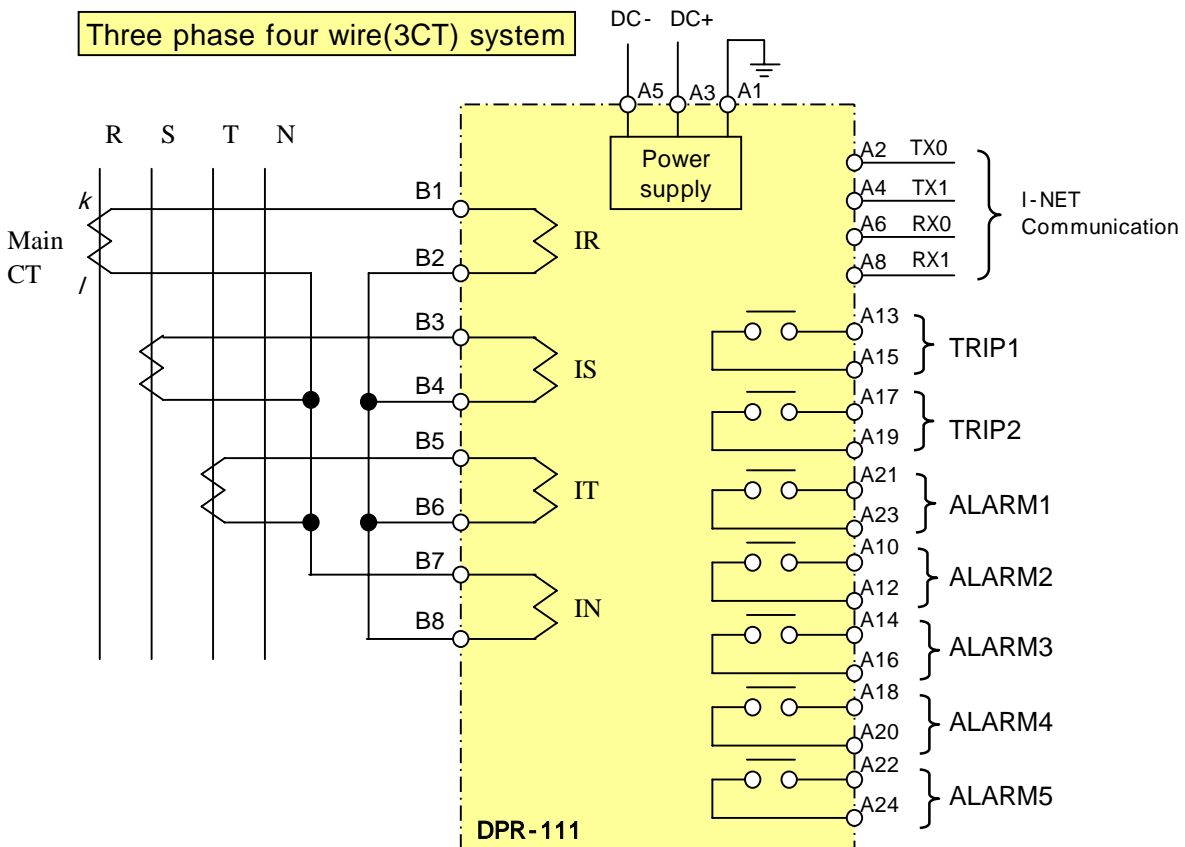

Three phase four wire(4CT) system

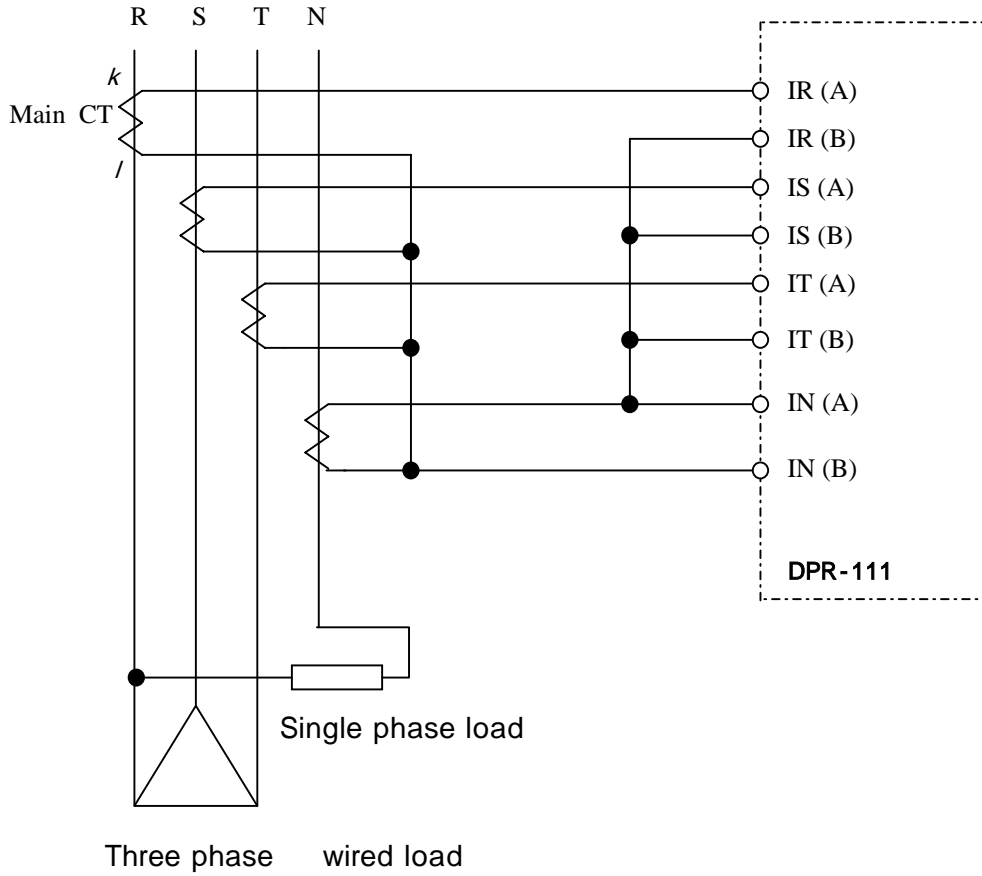

1.5 Output contacts

OCR and OCGR provide seven(7) output contacts.

Two of those are trip contacts to trip a circuit breaker and the others are for alarm signals.

1) Trip contacts

Two trip contacts TRIP1 and TRIP2 are used to give a circuit breaker trip signals.

Trip conditions can be assigned to each contacts as follows.

- Common trip : trip in the event of all kinds of faults (Factory default set)
- Time delay trip : trip by time delay trip signal
- Instant trip : trip by instant trip signal

Contact rating : 250V AC 10A

Do not use trip contacts for the purpose of alarm contacts

2) Alarm contacts

These contacts are to give signals in the events of trip, overload and self-diagnosis error, etc.

Five(5) alarm contacts are available here and are operated by the set conditions of users.

Contact rating : 250V AC 5A

Do not use these contacts for the purpose of trip conatcts.

3) Terminal Blocks of DPR-111

OCR/OCGR-A				OCR/OCGR-B			
1	F.G	2	TX0	1	Rk	2	R
3	DC +	4	TX1	3	Sk	4	S
5	DC -	6	RX0	5	Tk	6	T
7		8	RX1	7	Nk	8	N
9		10	ALARM2	9		10	
11		12	ALARM2	11		12	
13	TRIP1	14	ALARM3	13		14	
15	TRIP1	16	ALARM3	15		16	
17	TRIP2	18	ALARM4	17		18	
19	TRIP2	20	ALARM4	19		20	
21	ALARM1	22	ALARM5	21		22	
23	ALARM1	24	ALARM5	23		24	

All terminals of LG DPR series have the same grade of insulation and withstand current properties.

Screws and Push-on blade type connectors can be used with them.

1.6 Front face configuration

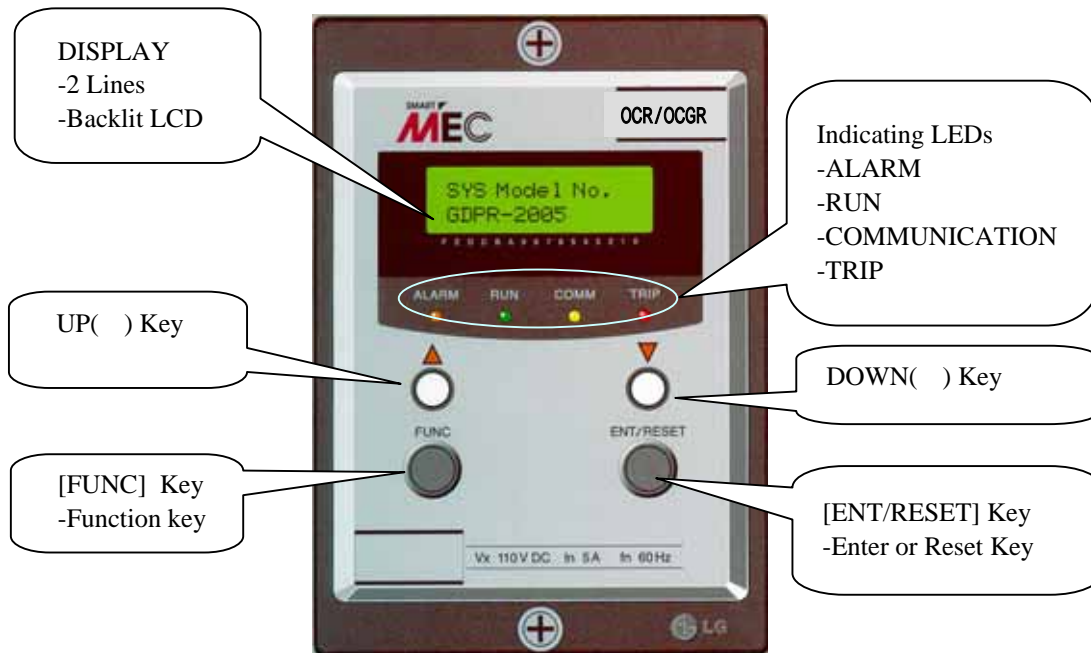

1. [FUNC] Function key to shift between menus
2. [ENT/RESET] Enter or Reset key
Press to move to a upper or lower menu.
Press to select the data after changing before saving it.
In the event of fault it is used to reset.
3. [▲] Press to increase the value of the data to be changed.
Press in case of YES to the question asking "Data Save ?"
Press to shift between upper menus.
- [▼] Press to decrease the value of the data to be changed.
Press in case of NO to the question asking "Data Save ?"
Press to shift between upper menus.
4. [_ F] Keeping pressing the Function key until the initial menu displayed.
It makes the menu options 00 to return to the initial from any menu.
5. [_ E] Keeping pressing the Enter key to reset in the event of fault.

1.7 Operation manual

1) Turn on and then RUN LED lights up and LCD displays as below.

LCD displays [Fig 1-1] for 3 sec and then shows [Fig 1-2].

[Fig 1-1]

				L		G		I		S				
	D	I	g	I	t	a	I		R	e	I	a	y	

[Fig 1-2]

Phase R		x	x	.	x	x	x	A		x	x	.	x	x	x	A	Phase S
Phase T		x	x	.	x	x	x	A		x	x	.	x	x	x	A	Phase N

It is normal running status. The RUN LED keeps lighting up.
Each phase current ampere is displayed.(xx.xxxA)

2) SYS DATA Menu

SYS DATA menu is displayed as shown in Fig 2 by pressing [FUNC] key.

[Fig 2]

1	.	S	Y	S		D	A	T	A					

2.1) To move to Password mode as shown in Fig 2-1 press [ENT/RESET] key.

[Fig 2-1]

P	a	s	s	w	o	r	d							
#	#	#	#											

- a) To change any data except Comm Channel(Communication Address) and Comm Baud rate (Communication speed) Password should be inputed.
- b) The factory default set Password is 0123. In case of inputing new Password do not forget it. Contact LG if your Password has been forgotton.
- c) How to input Password 0123

In the Password mode press () key once and then press [ENT/RESET] key.

O is inputed at the first digit as shown in Fig 2-2.

[Fig 2-2]

P	a	s	s	w	o	r	d							
#	#	#	#											

↓ Press () key and [ENT/RESET] key in order

P	a	s	s	w	o	r	d							
0	#	#	#											

Press () key once and press [ENT/RESET] key in order.

1 is inputted at the second digit as shown in Fig 2-3.

[Fig 2-3]

P	a	s	s	w	o	r	d								
0	#	#	#												



Press () key and [ENT/RESET] key in order

P	a	s	s	w	o	r	d								
0	1	#	#												

Press () key once and press [ENT/RESET] key in order.

2 is inputted at the third digit as shown in Fig 2-4.

[Fig 2-4]

P	a	s	s	w	o	r	d								
0	1	#	#												



Press () key and [ENT/RESET] key in order

P	a	s	s	w	o	r	d								
0	1	2	#												

Press () key once and press [ENT/RESET] key in order.

3 is inputted at the last digit as shown in Fig 2-5.

[Fig 2-5]

P	a	s	s	w	o	r	d								
0	1	2	#												



Press () key

P	a	s	s	w	o	r	d								
0	1	2	3												



Press [ENT/RESET] key

	D	a	t	a		S	a	v	e		?				
	Y	e	s	(U	P)		N	o	(D	N)	

* In case of inputting the correct Password

Press () key to the question " Data Save? " and then the RUN LED blinks (flash on and off).

The LCD displays Fig 2-6 and it is allowed to change and save new data.

[Fig 2-6]

P	a	s	s	w	o	r	d								
#	#	#	#												

* In case of inputing the Password incorrectly,
 Press () key to the question " Data Save? " and then the RUN LED lights up (flash on).
 The LCD displays Fig 2-7 and it is not allowed to change any data.

[Fig 2-7]

P	a	s	s	w	o	r	d										
#	#	#	#														

d) How to input New Password

To change Password first input the existing Passord according to the procedure c).
 When the RUN LED blinks input new Password.

2.2) To move to Comm Channel mode as shown in Fig 2-8 press [FUNC] key.
 Communication address can be set here from 1 through 255 by using (), () keys.
 It is required only for communication. Please set 000 in case of no communication.

[Fig 2-8]

C	o	m	m	.		C	h	a	n	n	e	l					
0	0	1															

* Changeable without inputing Password

2.3) To move to Comm Baud rate mode as shown in Fig 2-9 press [FUNC] key.
 Communication speed can be set here among 2400, 4800, 9600 and 19200.

[Fig 2-9]

C	o	m	m	.		B	a	u	d		r	a	t	e			
	9	6	0	0													

* Changeable without inputing Password

* Factory default set is to 9600.

2.4) Press [FUNC] key to move to Exit mode.

[Fig 2-10]

	E	x	i	t													

To move to 2.SYS info menu press [ENT/RESET] key

3) SYS Info Menu

To move to 2. SYS info menu from 1. SYS DATA menu press [FUNC]

[Fig 3]

2	.	S	Y	S		I	n	f	o								

3.1) In case of DPR-011 (OCR)

Pressing [ENT/RESET] key, LCD displays the model OCR as below.

This OCR covers only R, S and T phase, not N phase.

[Fig 3-1]

R	e	I	a	y		I	n	f	o						
O	C	R													

3.2) In case of DPR-111 (OCR/OCGR)

Pressing [ENT/RESET] key, LCD displays the model OCR + OCGR as below which covers R, S, T and N phase.

Here one between OCR and OCR+OCGR can be selected by using (), () keys.

In case of OCR selected the above 3.1) function is applied.

[Fig 3-2]

R	e	I	a	y		I	n	f	o						
O	C	R		+		O	C	G	R						

* How to select : Move to OCR or OCR+OCGR by (), () keys and Press [ENT/RESET] key and () key in order.

* **Password protected**

3.3) Pressing [FUNC] key, Rated current 5A is displayed.

It is same to both DPR-011 and DPR-111 and is not changeable.

[Fig 3-3]

R	a	t	I	n	g		C	u	r	r					
5		A													

3.4) Pressing [FUNC] key, SYS Model Numbers are displayed as shown in Fig 3-4.

Those are DPR-011 for OCR and DPR-111 for OCR/OCGR which are not changeable.

[Fig 3-4]

S	Y	S		M	o	d	e	I		N	o	.			
D	P	R	-	0	1	1	S								

(DPR-OCR)

S	Y	S		M	o	d	e	I		N	o	.			
D	P	R	-	1	1	1	S								

(DPR-OCR/OCGR)

3.5) Pressing [FUNC] key, SYS Firmware No is displayed as shown in Fig 3-5.

The No. is OCR_Vx_x for both DPR-011 and DPR-111 which is not changeable.

[Fig 3-5]

S	Y	S		F	I	r	m	w	a	r	e		N	o	.
O	C	R	_	V	x	_	x								

* DPR-011 and DPR-111 use the same No.

* x is Version of Firmware assigned by the maker.

3.6) Pressing [FUNC] key, SYS Serial ID with 8 digits is displayed as shown in Fig 3-6.

It is not changeable.

[Fig 3-6]

S	Y	S		S	e	r	I	a	I		I	D			
S	N	.	x	x	x	x	x	x	x	x					

* x is the No. of manufacture assigned by the maker.

3.7) Pressing [FUNC] key, Comm Module is displayed as shown in Fig 3-7.

It depends on the communication system and is not changeable.(Communication option)

[Fig 3-7]

C	o	m	m	.	M	o	d	u	l	e					
I	-	N	E	T											

(in case of I-NET)

3.8) Pressing [FUNC] key, Comm Version is displayed as shown in Fig 3-8 which is not changeable

[Fig 3-8]

C	o	m	m	.		V	e	r	s	i	o	n			
x	x	x	x												

* x is the version No. of communication module assigned by the maker.

3.9) Press [FUNC] key to move to Exit mode.

[Fig 3-9]

	E	x	i	t											

To move to 3.FAULT Info menu press [ENT/RESET] key

4) FAULT Info Menu (**unchangeable**)

To move to 3.FAULT Info menu from previous menu press [FUNC]key.

[Fig 4]

3	.	F	A	U	L	T		I	n	f	o				

4.1) Pressing [ENT/RESET] key, the latest fault current of R phase is displayed as below.
It is not changeable.

[Fig 4-1]

F	a	u	l	t		I	1										
		x	x	.	x	x	A										

* x is fault current.

4.2) Pressing [FUN] key, the latest fault current of S phase is displayed as below.
It is not changeable.

[Fig 4-2]

F	a	u	l	t		I	2										
		x	x	.	x	x	A										

* x is fault current.

4.3) Pressing [FUN] key, the latest fault current of T phase is displayed as below.
It is not changeable.

[Fig 4-3]

F	a	u	l	t		I	3										
		x	x	.	x	x	A										

* x is fault current.

4.4) Pressing [FUN] key, the latest fault current of N phase is displayed as below.
It is not changeable.

[Fig 4-4]

F	a	u	l	t		I	4										
		x	x	.	x	x	A										

* x is fault current.

Note : In case of using DPR-011(OCR) and OCR selected in DPR-111(OCR/OCGR)
this mode is not applied.

4.5) Pressing [FUN] key, the fault flag is displayed as below.
Reset to save the present fault data here.

[Fig 4-5]

Ex.1) Instantaneous trip caused by R phase

F	a	u	l	t		f	l	a	g	-	1						
I	>	:					I	>>	:	1							

Ex.2) Instantaneous trip caused by R, S and T phases

F	a	u	l	t		f	l	a	g	-	1						
I	>	:					I	>>	:	1	2	3					

Ex.3) Time delay trip caused by R phase

F	a	u	l	t		f	l	a	g	-	1				
I	>	:	1			I	>>	:							

Ex.4) Time delay trip caused by R, S and T phases

F	a	u	l	t		f	l	a	g	-	1				
I	>	:	1	2	3		I	>>	:						

Ex.5) Instantaneous and Time delay trip caused by R, S, T and N phases

F	a	u	l	t		f	l	a	g	-	1				
I	>	:	1	2	3	4		I	>>	:	1	2	3	4	

* It is not applied to OCR.

4.6) Pressing [FUNC] key, Fig 4-6 displays the preceding fault record that is previous to the Fig4-5 It is not changeable.

[Fig 4-6]

Ex.) Time delay trip caused by R and S phases

F	a	u	l	t		f	l	a	g	-	2				
I	>	:	1	2			I	>>	:						

4.7) Pressing [FUNC] key, Fig 4-7 displays the preceding fault record that is previous to the Fig4-6 It is not changeable.

[Fig 4-7]

Ex.) Time delay trip caused by R and S phases

F	a	u	l	t		f	l	a	g	-	3				
I	>	:	1	3			I	>>	:						

4.8) Pressing [FUNC] key, Fig 4-8 displays the preceding fault record that is previous to the Fig4-7 It is not changeable.

[Fig 4-8]

Ex.) Time delay trip caused by S and T phases

F	a	u	l	t		f	l	a	g	-	4				
I	>	:	2	3			I	>>	:						

4.9) Press [FUNC] key to move to Fault clear mode.

Here all records in FAULT Info Menu can be cleared by pressing [ENT/RESET] and () keys in order.

[Fig 4-9]

A	L	L		F	a	u	l	t		C	L	R			
C	L	E	A	R	=		E	N	T		K	e	y		

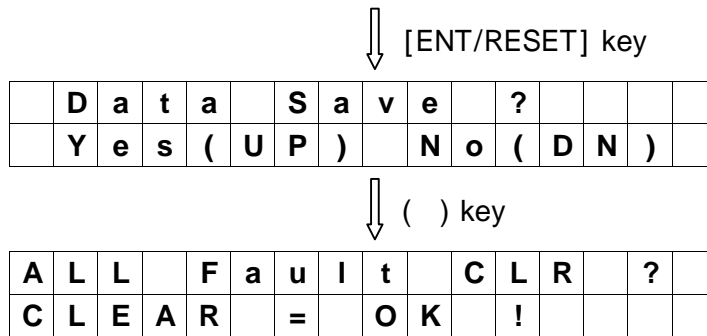

4.10) Press [FUNC] key to move Exit mode.

[Fig 4-10]

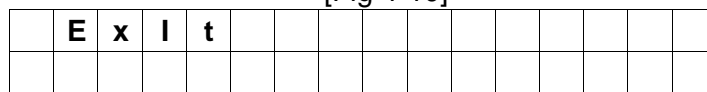

To move to 4.MEASUREMENTS menu press [ENT/RESET] key

5) MEASUREMENTS Menu

To move to 4.MEASUREMENTS menu from previous menu press [FUNC]key.

[Fig 5]

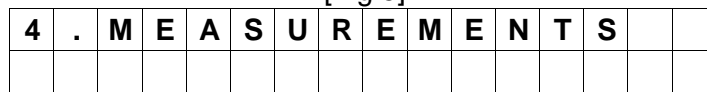

5.1) Pressing [ENT/RESET] key, the secondary current of the CT of each phase is displayed as shown in Fig5-1. The load current of each phase can be calculated from this displayed currents and CT ratio.

[Fig 5-1]

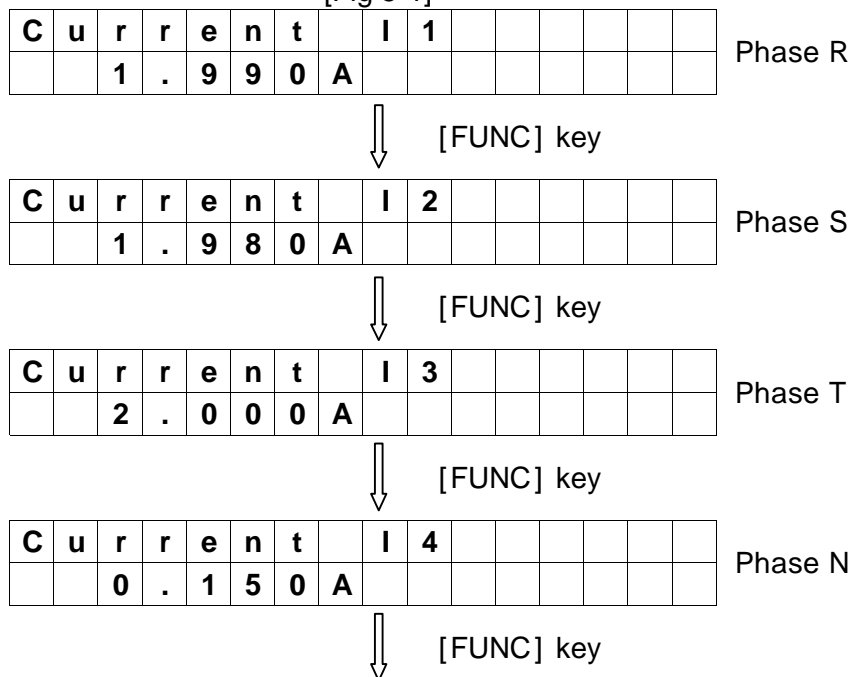

M	a	x		C	u	r	r	e	n	t				
		2	.	0	0	0	A	:		I	3			

Phase with the highest value

* Mode for phase N is not applied to OCR.

5.2) Calculation of the load

Ex.) If CT ration is 1000:5 and the displayed value for phase T is 2.0 A, the load of phase T is 400A.

5.3) Press [FUNC] key to move to Exit mode.

[Fig 5-2]

	E	x	I	t										

To move to 5.OCR SETTING menu press [ENT/RESET] key

6) OCR SETTING Menu (Password protected)

To move to 5.OCR SETTING menu from previous menu press [FUNC]key.

[Fig 6]

5	.	O	C	R		S	E	T	T	I	N	G		

6.1) Press [ENT/RESET] key and TD-SET mode is displayed below.

Time delay current can be set here from 1 to 16A at the interval of 0.5A.

[Fig 6-1]

T	D	-	S	E	T									
	1	6	.	0	A									

* Press (), () keys to adjust the value of the current.

6.2) Press [FUNC] key to move to the TD-Characteristic mode.

5 options of characteristic curves are available here.

[Fig 6-2]

T	D	-	C	h	a	r	a	c	t	.				
S	t	a	n	d	a	r	d		I	n	v			

standard inverse curve, SI

() key ↓ ↑ () key

T	D	-	C	h	a	r	a	c	t	.				
V	e	r	y		I	n	v							

very inverse curve, VI

() key ↓ ↑ () key

T	D	-	C	h	a	r	a	c	t	.				
E	x	t	r	e	m	e	i	y		I	n	v		

extremely inverse curve, EI

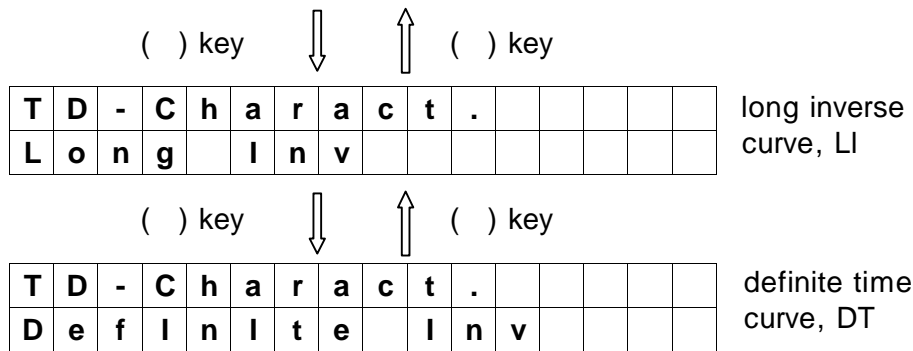

Ex.) Changing the curve to VI(very inverse) from SI(standard inverse)

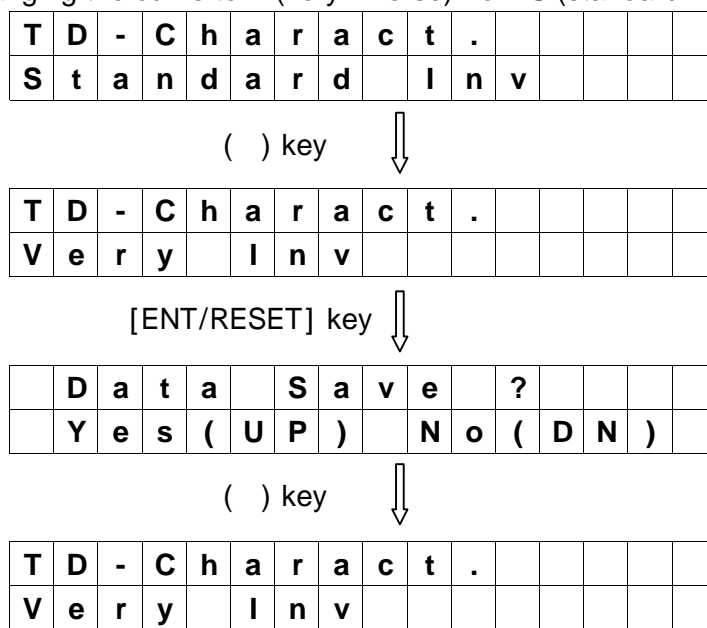

6.3) Press [FUNC] key to move to TD-TimeTap mode.

Delay time can be set here from 0.05 to 1.0 at the interval of 0.01.

[Fig 6-3]

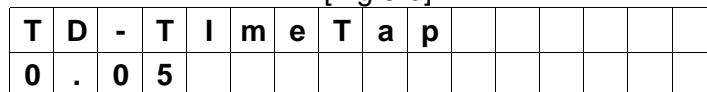

Note : Definite time setting can be done in Definite Inv Mode from 0.1~10sec at the interval of 0.1 sec.

Ex.) Changing delay time to 0.1 from 0.05.

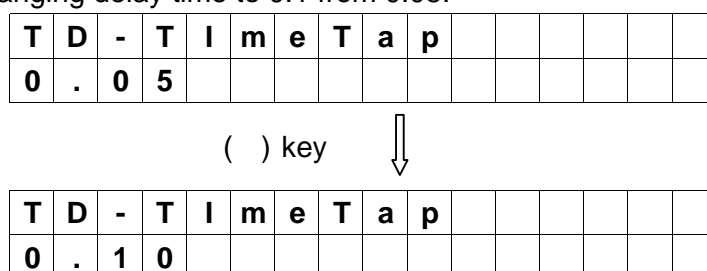

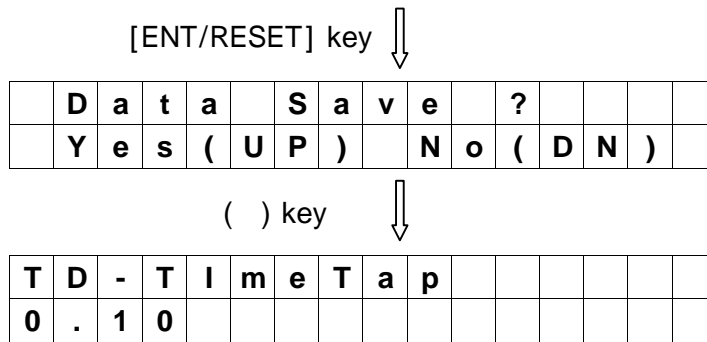

6.4) Press [FUNC] key and Instantaneous-Lock mode is displayed.
 This mode is to select between Lock and UnLock.
 When it is set to Lock the Instantaneous Mode is not displayed.

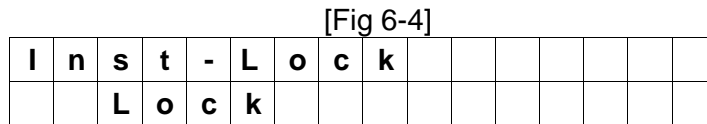

- * If Lock is selected the Instantaneous trip is not activated.
- * Press [FUNC] key to move to Exit.

Ex.) Changing of setting to Unlock from Lock.

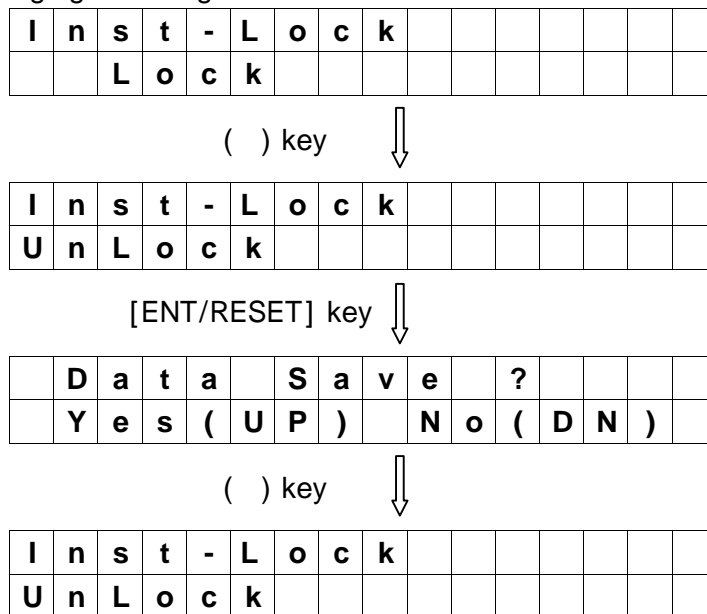

6.5) How to set Instantaneous current when the Unlock is selected.
 Instantaneous current can be set from 10 to 160A at the interval of 5A.

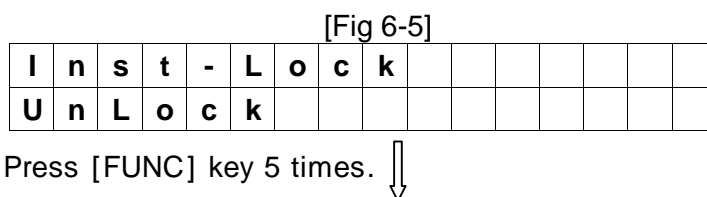

I	N	S	T	-	S	E	T										
	1	6	0	A													

160A is set at the present.

Ex.) To set a new data 60A

I	N	S	T	-	S	E	T										
	1	6	0	A													

Press () key until
60A appears.



I	N	S	T	-	S	E	T										
		6	0	A													

[ENT/RESET] key



	D	a	t	a		S	a	v	e		?						
	Y	e	s	(U	P)		N	o	(D	N)			

Press () key to save it.



I	N	S	T	-	S	E	T										
		6	0	A													

6.6) To move to the next mode press [FUNC] key.

[Fig 6-6]

I	N	S	T	-	S	E	T										
		6	0	A													

[FUNC] key



I	n	s	t	-	L	o	c	k									
U	n	L	o	c	k												

[FUNC] key



	E	x	I	t													

* Press [ENT/REST] key to move to OCGR SETTING Mode here.

7) OCGR SETTING Menu (Password protected.)

Prior to enter into this OCGR SETTING Menu be sure that OCR+OCGR is selected in the 2.SYS Info menu of DPR-OCR/OCGR (DPR-111) Model.

Press [FUNC] key to move to 6.OCGR SETTING menu.

[Fig 7]

6	.	O	C	G	R		S	E	T	T	I	N	G				

7.1) Press [ENT/RESET] key and TD-SET mode is displayed as below.

Time delay current can be set here from 0.2 to 2.5A at the interval of 0.1A.

[Fig 7-1]

T	D	-	S	E	T												
			2	.	5	A											

* Press (), () keys to adjust the value of the current.

7.2) Press [FUNC] key to move to the TD-Characteristic mode.

5 options of characteristic curves are available here.

[Fig 7-2]

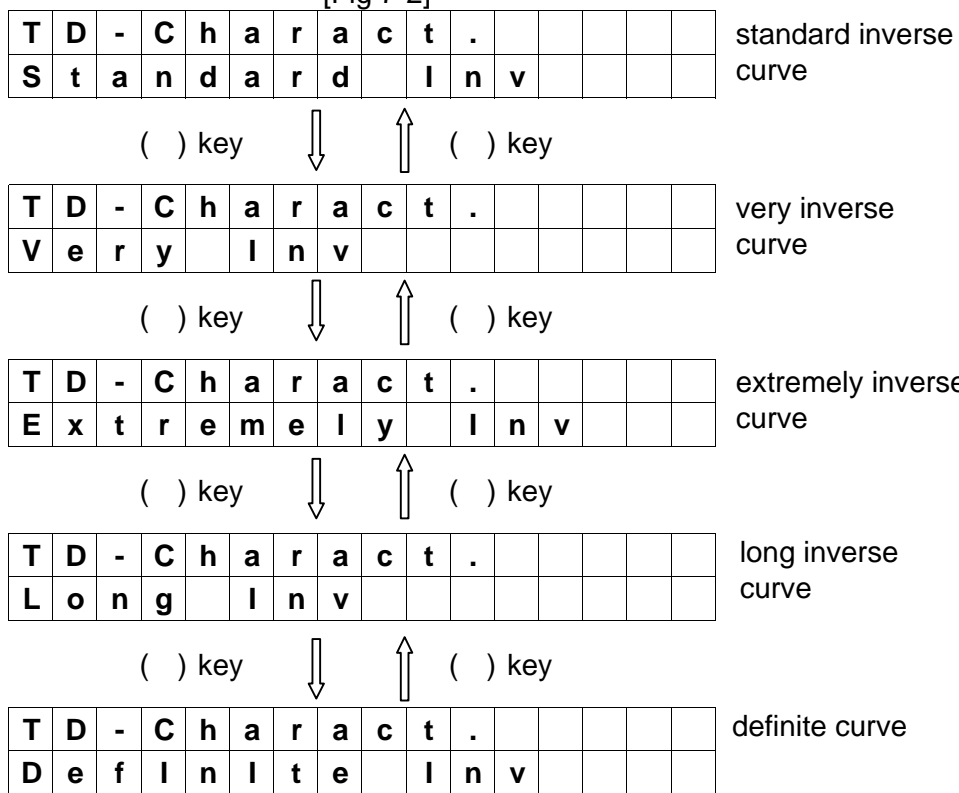

Ex.) Changing the curve to VI(very inverse) from SI(standard inverse)

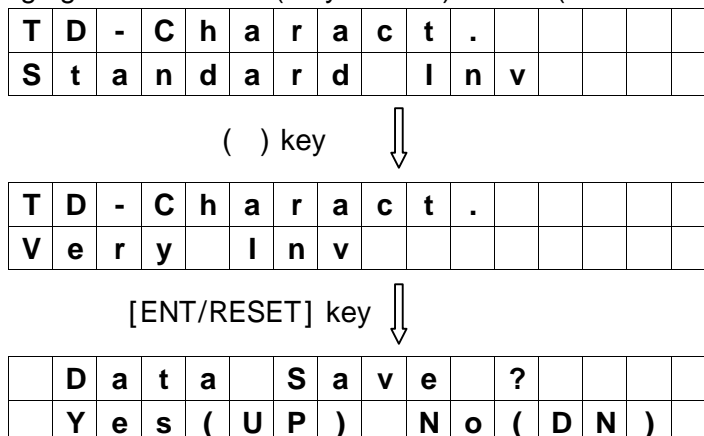

() key ↓

T	D	-	C	h	a	r	a	c	t	.				
V	e	r	y			I	n	v						

7.3) Press [FUNC] key to move to TD-TimeTap mode.

Delay time can be set here from 0.05 to 1.0 at the interval of 0.01.

[Fig 7-3]

T	D	-	T	I	m	e	T	a	p					
0	.	0	5											

Ex.) Changing delay time to 0.1 from 0.05.

T	D	-	T	I	m	e	T	a	p					
0	.	0	5											

() key ↓

T	D	-	T	I	m	e	T	a	p					
0	.	1	0											

[ENT/RESET] key ↓

	D	a	t	a	S	a	v	e	?					
	Y	e	s	(U	P)		N	o	(D	N)

() key ↓

T	D	-	T	I	m	e	T	a	p					
0	.	1	0											

7.4) Press [FUNC] key and Instantaneous-Lock mode is displayed.

This mode is to select between Lock and UnLock.

When it is set to Lock the Instantaneous Mode is not displayed.

[Fig 7-4]

I	n	s	t	-	L	o	c	k						
		L	o	c	k									

* If Lock is selected the Instantaneous trip is not activated.

* Press [FUNC] key to move to Exit.

Ex.) Changing of setting to Unlock from Lock.

I	n	s	t	-	L	o	c	k						
		L	o	c	k									

() key ↓

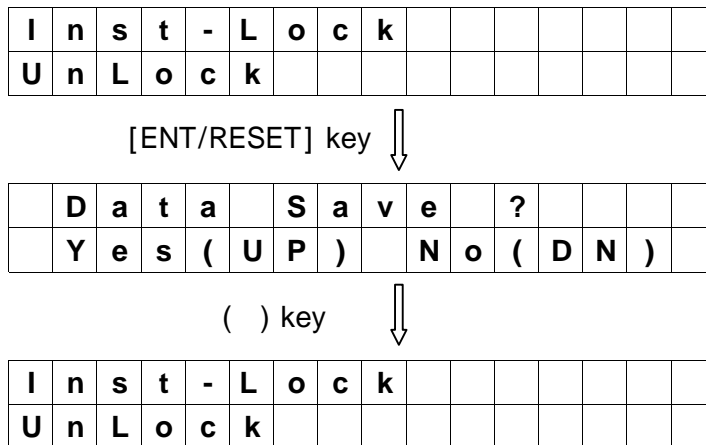

7.5) How to set Instantaneous current when the Unlock is selected.

Instantaneous current can be set from 2.5 to 40A at the interval of 2.5A.

[Fig 7-5]

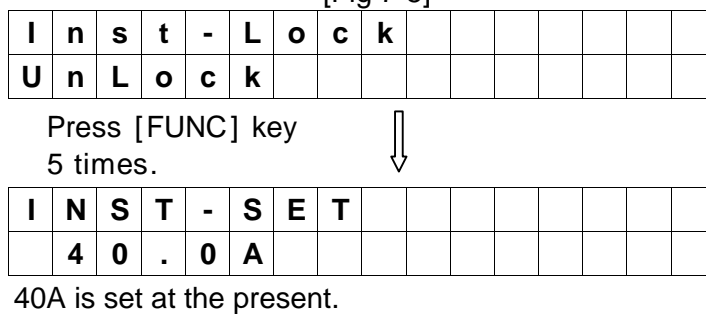

Ex.) To set a new data 4A

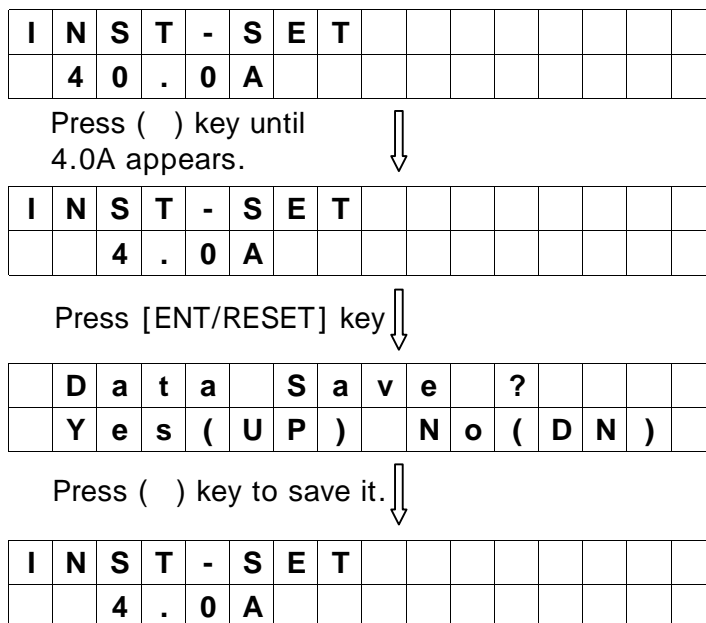

7.6) To move to the next mode press [FUNC] key.

[Fig 7-6]

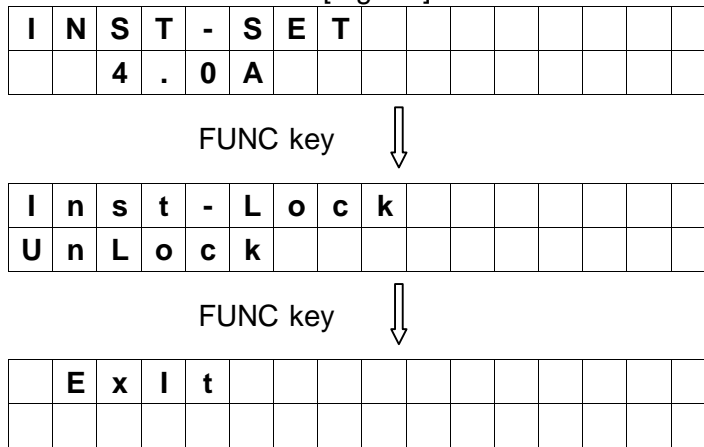

* Press [ENT/REST] key at this mode to move to DO SETTING menu.

8) Press [FUNC] key to move to 7.DO SETTING menu.

[Fig 8]



8.1) Pressing [ENT/RESET] key, the present Relay output status are displayed as below.

[Fig 8-1]

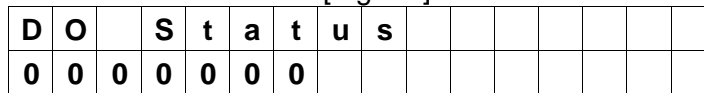

* It consists of 7 digits and each digit shows the status of the corresponding Relay output. 0 indicates Relay off and 1 indicates On status.

Ex.) Chart below indicates only the 4th Relay is on status.

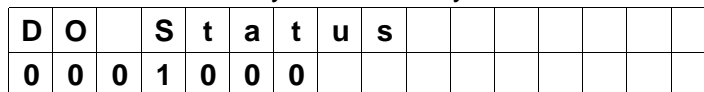

* It is not latched but depends on the user's DO SETTING.

8.2) Output contacts configuration

The output contacts are designed to be set by user's requirements as shown in Fig 8-2.

Combination logic among them is also possible as follows.

ALM-I1, ALM-I2 and ALM-I3 can be combined by [OR].

If this group combined again with TRIP-TD by [AND], the output is made only in the case of a time delay trip.

[Fig 8-2]

Setting		contact		For TRIP		For ALARM					Use of contacts	
		TRIP1	TRIP2	ALARM1	ALARM2	ALARM3	ALARM4	ALARM5				
TRIP RELAY	TRIP			X	X	X	X	X	X	X	TRIP	
	TRIP-INST			X	X	X	X	X	X	X	Instantaneous TRIP	
	TRIP-TD			X	X	X	X	X	X	X	Time delay TRIP	
ALARM RELAY	ALM-TRIP	X	X							X	Alarm TRIP	
	ALM-INST	X	X							X	Instantaneous TRIP	
	ALM-TD	X	X							X	Time delay TRIP	
	ALM-I1	X	X							X	R phase TRIP	
	ALM-I2	X	X							X	S phase TRIP	
	ALM-I3	X	X							X	T phase TRIP	
	ALM-I4	X	X							X	N phase TRIP	
	ALM-Sys Fail	X	X	X	X	X	X	X				Self-diagnostic Error
	PICK-UP	X	X								X	Overload signal
NO USE	X	X								X	No use	

Note 1 : Factory set User set. If necessary. X : Not available

Note 2 : Do not use ALARM Relays instead of TRIP(CB CONTROL) contacts.

Note 3 : If TRIP1 and TRIP2 conatcts are operated, the both status before and after event are stored.

Note 4 : DPR-OCR (DPR-011) has not ALM-I4.

8.3) Press [FUNC] key to move to the mode to set the function of TRIP1 Relay.

The functional options are TRIP, Instantaneous TRIP and time delay TRIP as follows.

[Fig 8-3]

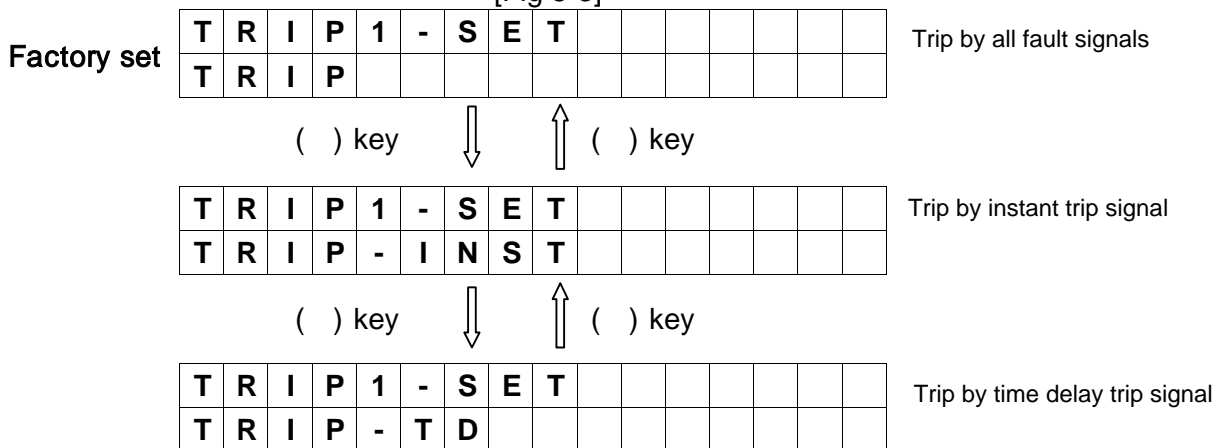

8.4) Press [FUNC] key to move to the mode to set the function of TRIP2 Relay.

The functional options are TRIP, Instantaneous TRIP and time delay TRIP as follows.

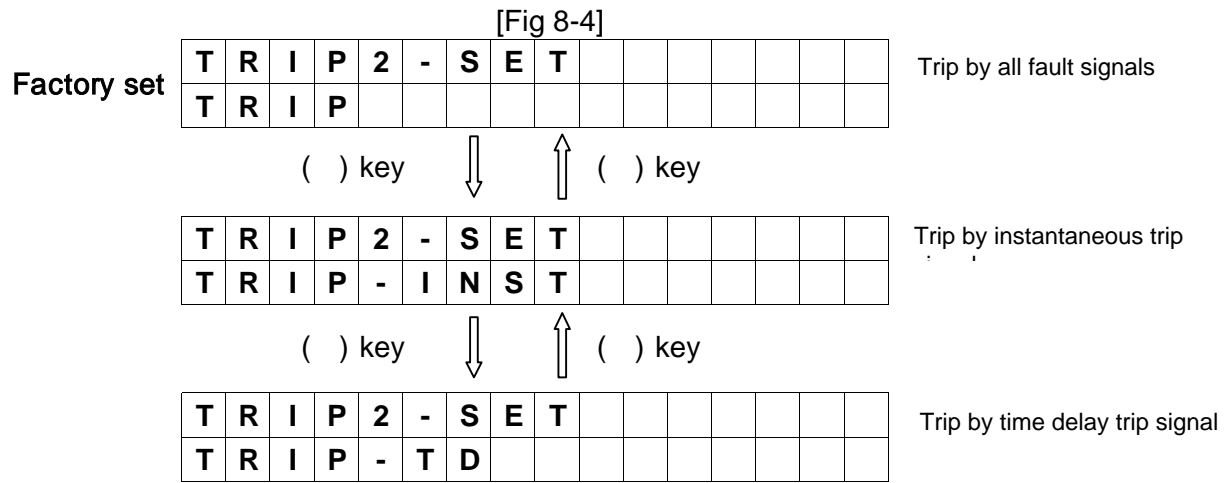

8.5) Press [FUNC] key to move to the mode to set the function of ALARM1 Relay.

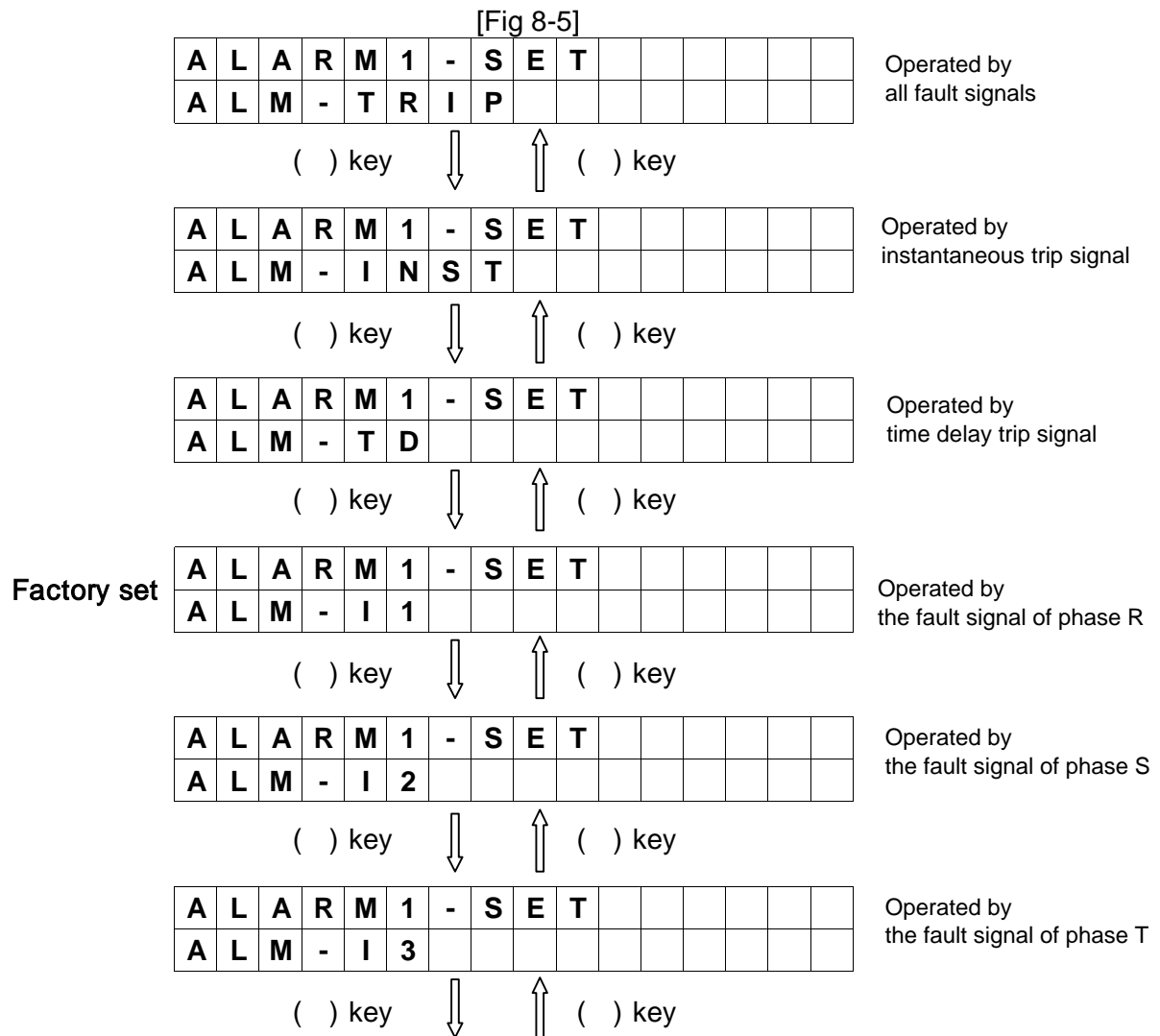

A	L	A	R	M	1	-	S	E	T						
A	L	M	-	I	4										

Operated by the fault signal of phase N

() key ↓ ↑ () key

A	L	A	R	M	1	-	S	E	T						
A	L	M	-	S	y	s	F	a	I	I					

Operated by Self-diagnosis Error signal

() key ↓ ↑ () key

A	L	A	R	M	1	-	S	E	T						
P	I	C	K	-	U	P									

Operated when the load reaches 100% of the set current.

() key ↓ ↑ () key

A	L	A	R	M	1	-	S	E	T						
N	O		U	S	E										

Alarm1 Relay is not in use.

Ex.) How to change the ALARM1-SET mode to PICK-UP from ALM-11.

Factory set

A	L	A	R	M	1	-	S	E	T						
A	L	M	-	I	1										

Operated by the fault signal of phase R

() key ↓ ↑ () key

A	L	A	R	M	1	-	S	E	T						
P	I	C	K	-	U	P									

Operated when the load reaches 100% of the set current.

[ENT/RESET] key ↓

	D	a	t	a		S	a	v	e		?					
	Y	e	s		(U	P)		N	o		(D	N)

() key ↓

A	L	A	R	M	1	-	S	E	T						
P	I	C	K	-	U	P									

Operated when the load reaches 100% of the set current.

8.6) Press [FUNC] key to move to the modes for setting the functions of ALARM2, ALARM3 and ALARM4 Relays. Refer to the above process 8.5) for detail.

8.7) Press [FUNC] key to move to **ALARM5-SET mode.**

It is only for ALM-SysFail that operates in the event of Self-diagnosis Error.

9) DATA displayed in the event of fault

9.1) When fault happens **TRIP LED lights up and LCD Backlit and RUN LED are blinking.**

LCD displays the status as follows.

[Fig 9]

Ex.1) Instantaneous tripping by phase R

	□		F	a	u	l	t		T	r	i	p		□
									I	>>	:	1		

Ex.2) Instantaneous tripping by phases R, S and T

	□		F	a	u	l	t		T	r	i	p		□
									I	>>	:	1	2	3

Ex. 3) Timedelay tripping by phase R

	□		F	a	u	l	t		T	r	i	p		□
	I	>	:	1										

Ex. 4) Timedelay tripping by phases R, S and T

	□		F	a	u	l	t		T	r	i	p		□
	I	>	:	1	2	3								

Ex. 5) Instantaneous and Timedelay tripping by phases R, S, T and N

	□		F	a	u	l	t		T	r	i	p		□	
	I	>	:	1	2	3	4		I	>>	:	1	2	3	4

* Phase N is not applied to OCR mode.

10) DATA displayed in the event of Self-diagnosis Error

Error signal is as shown in Fig 10.

[Fig 10]

S	Y	S		S	t	a	t	u	s						
E	R	R	0	R		x									

* In the event of happening more than one Error at the same time all Error codes are displayed.
(Ex. ERROR 124)

2. Selective Ground Relay(SGR: Selective Earth Fault Protection)

2.1 Features and specifications

Self-diagnostics	High speed serial data communication
Fault recording	International standard applied
Sequence of Event(S.O.E)	- IEC 255, IEC 1000-4, KEMC 1120

Type designation		DPR-211
ANSI code		67G
Ratings	Zero phase current(Ion)	1.5mA
	Frequency(fn)	50/60Hz
	Zero sequence voltage(Von)	190V or $190\sqrt{3}$ V
	Control power(Vx)	DC 110/125V (DC 85~150V)
	Input burdens	0.5VA and below
Relay elements		Selective Earth Fault Protection (SGR)
Setting range	Operating current(Io)	0.9~5.4mA/0.3mA
	Operating voltage(Vo)	4~76V/4V
	Operating phase angle	0°, 30°, 45°, 60°, 90°
Operating time	Definite time	0.1~10seconds in a 0.1 step
Ancillary function		Self-diagnostics, Fault records, Sequence of Event (S.O.E)
Communication mode		I-NET
Display		Back-lit LCD (Dot Matrix)
Output contacts	Switching capacity	Make 10A/250Vac, 0.5sec, Resistive Load Break 1A/250Vac 0.1PF
	Constitution(3EA)	Trip Relay 1a, 1250VA and over Alarm Relay 1a System Fail Relay 1a
	Type	at Trip operation Trip Relay + Trip LED + Alarm Relay self-diagnostics error System Fail Relay+Alarm LED at Normal RUN LED
	Insulation Resistance	DC 500V 100MΩ and over
Dielectric withstand		2kV(1kV) rms. and over for 1 minute
High Voltage Impulse		5kV(3kV) peak and over applied for 1.2x50μs
Overload capacity	Voltage circuit	Vn x 1.15 for 3 hours
Temperature	Operating	-10 ~ 55
	Storage	-20 ~ 70
Humidity		80% RH (Non-condensing)
Applicable standard		IEC 255, IEC1000-4, KEMC 1120
Weight		2.8kg
Dimension		124mm (width), 177mm (height), 243mm (depth)

2.2 Block Diagram

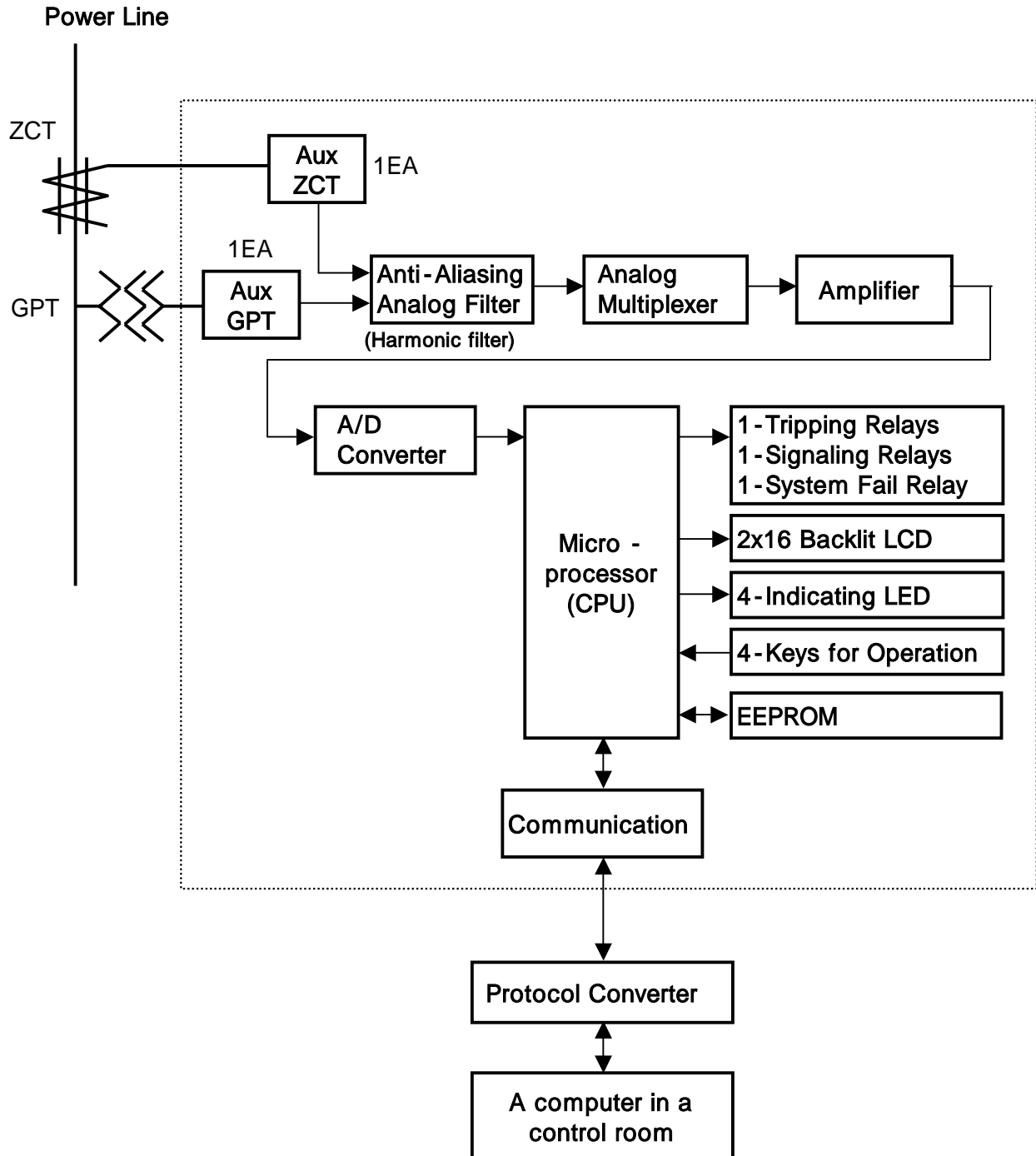

2.3 Application

Feeder Protection

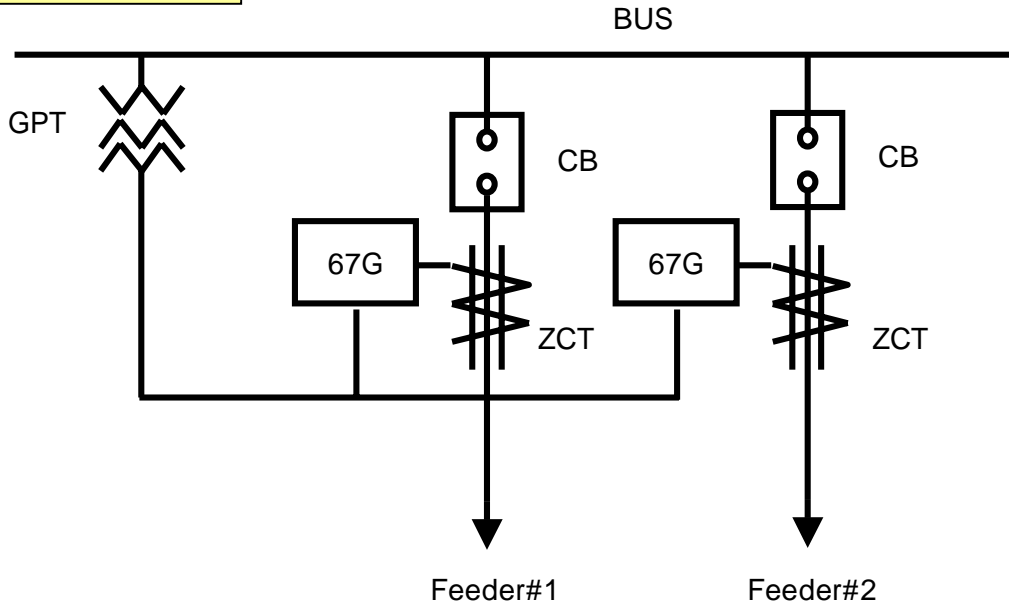

2.4 Wiring

3 phase 3 wire non-grounded system

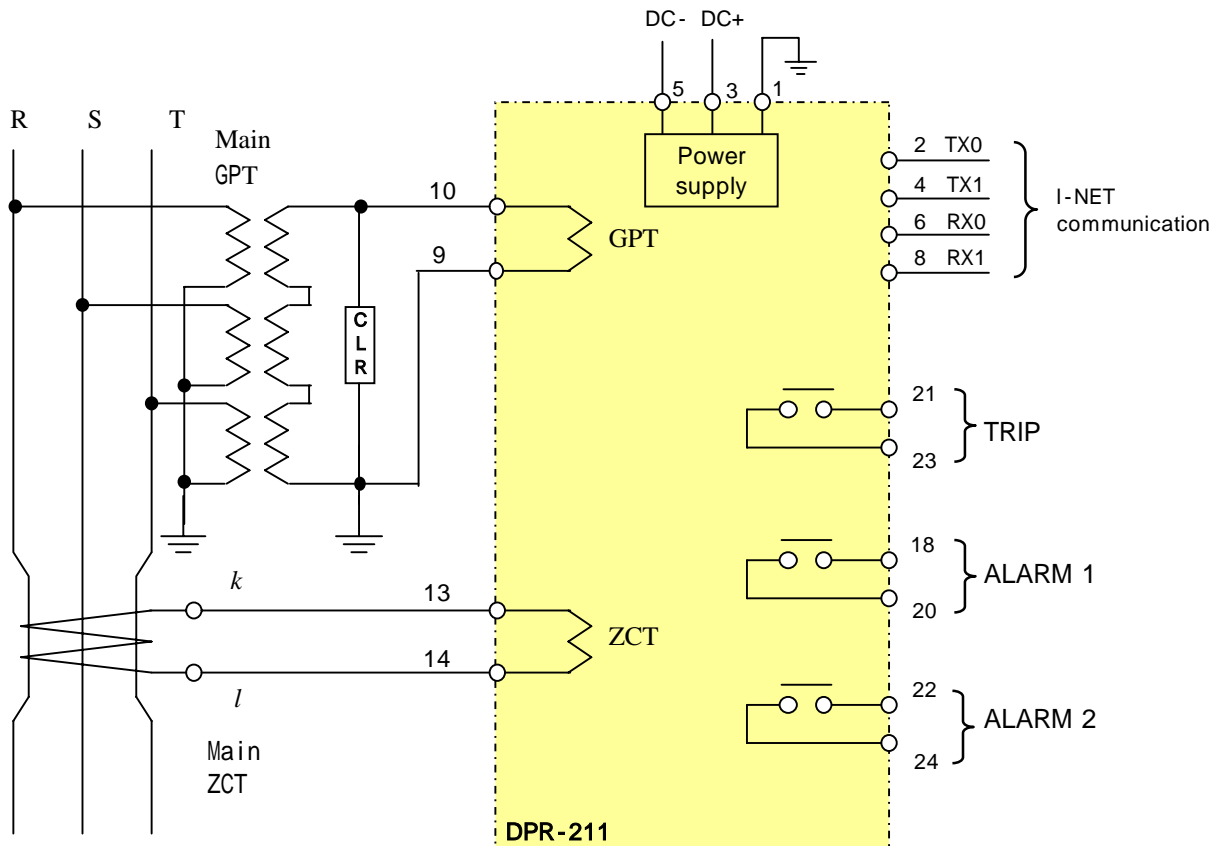

2.5 Output contacts

SGR provides three(3) output contacts.

One of those are trip contacts to trip a circuit breaker and the others are for alarm signals.

1) Trip contacts

The trip contact is to give a circuit breaker trip signals.

Do not use this contact for the purpose of alarm contact.

Contact rating : 250V AC 10A

2) Alarm contacts

These contacts are to give signals in the events of fault (ALARM1) and self-diagnosis error(ALARM2).

Do not use these contacts for the purpose of trip contact.

Contact rating : 250V AC 5A

3) Terminal Blocks of DPR-211

SGR			
1	F.G	2	TX0
3	DC +	4	TX1
5	DC -	6	RX0
7		8	RX1
9	GPTk	10	GPTI
11		12	
13	ZCTk	14	ZCTI
15		16	
17		18	ALARM1
19		20	ALARM1
21	TRIP	22	ALARM2
23	TRIP	24	ALARM2

All terminals of LG DPR series have the same grade of insulation and withstand current properties.

Screws and Push-on blade type connectors can be used with them.

2.6 Front face configuration

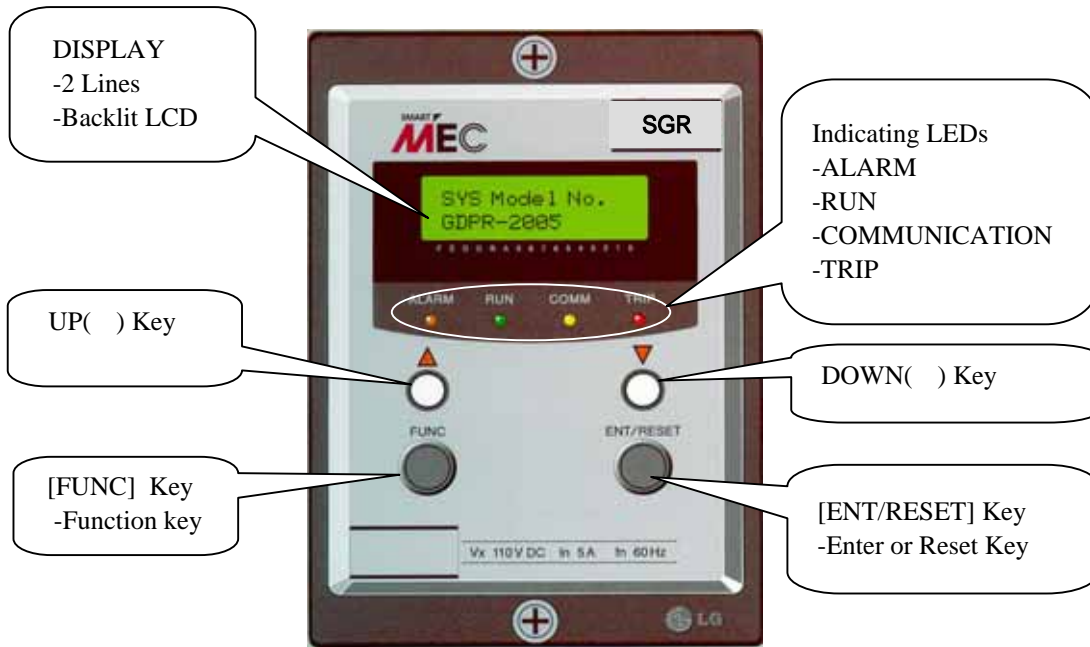

1. [FUNC] Function key to shift between menus
2. [ENT/RESET] Enter or Reset key
 Press to move to a upper or lower menu.
 Press to select the data after changing before saving it.
 In the event of fault it is used to reset.
3. [] Press to increase the value of the data to be changed.
 Press in case of YES to the question asking "Data Save ?"
 Press to shift between upper menus.
- [] Press to decrease the value of the data to be changed.
 Press in case of NO to the question asking "Data Save ?"
 Press to shift between upper menus.
4. [_ F] Keeping pressing the Function key until the initial menu displayed.
 It makes the menu options 00 to return to the initial from any menu.
5. [_ E] Keeping pressing the Enter key to reset in the event of fault.

2.7 Operation manual

- 1) Turn on and then RUN LED lights up and LCD displays as below.
 LCD displays [Fig 1-1] for 3 sec and then shows [Fig 1-2].

[Fig 1-1]

			L		G		I		S				
	D	I	g	I	t	a	I		R	e	I	a	y

[Fig 1-2]

	V	o	:			x	.	x	x	x	V		
	I	o	:			x	.	x	x	x	m	A	

It is normal running status. The RUN LED keeps lighting up.
 X.XXX are the values of zero-phase volts and amps.

2) SYS DATA Menu

SYS DATA menu is displayed as shown in Fig 2 by pressing [FUNC] key.

[Fig 2]

1	.	S	Y	S		D	A	T	A				

- 2.1) To move to Password mode as shown in Fig 2-1 press [ENT/RESET] key.

[Fig 2-1]

P	a	s	s	w	o	r	d						
#	#	#	#										

- a) To change any data except Comm Channel(Communication Address) and Comm Baud rate (Communication speed) Password should be inputed.
- b) The factory default set Password is 0123. In case of inputing new Password do not forget it. Contact LG if your Password has been forgotton.
- c) How to input Password 0123

In the Password mode press () key once and then press [ENT/RESET] key.
 O is inputed at the first digit as shown in Fig 2-2.

[Fig 2-2]

P	a	s	s	w	o	r	d						
#	#	#	#										

↓ Press () key and [ENT/RESET] key in order

P	a	s	s	w	o	r	d						
0	#	#	#										

Press () key once and press [ENT/RESET] key in order.

1 is inputed at the second digit as shown in Fig 2-3.

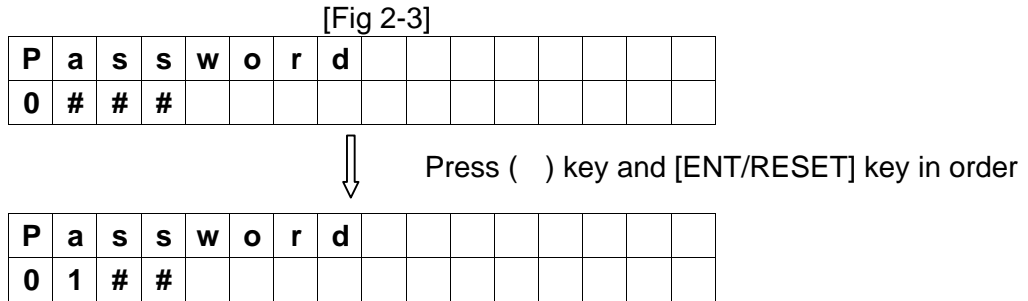

Press () key once and press [ENT/RESET] key in order.

2 is inputed at the third digit as shown in Fig 2-4.

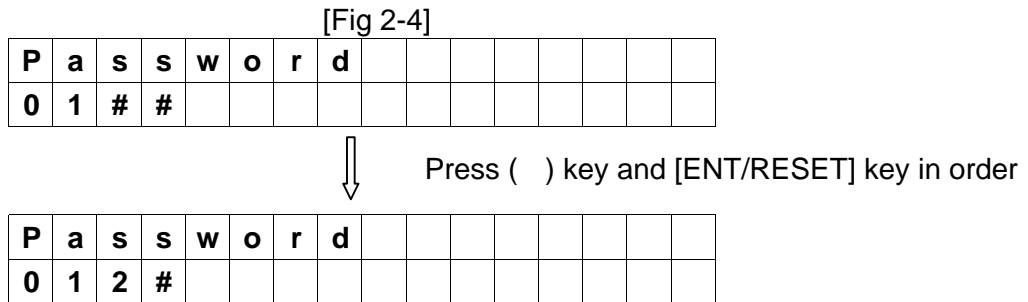

Press () key once and press [ENT/RESET] key in order.

3 is inputed at the last digit as shown in Fig 2-5.

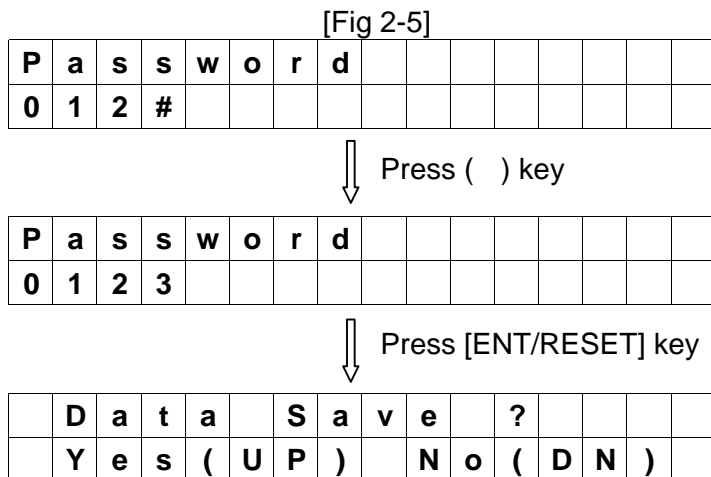

* In case of inputing the correct Password

Press () key to the question " Data Save? " and then the RUN LED blinks (flash on and off).

The LCD displays Fig 2-6 and it is allowed to change and save new data.

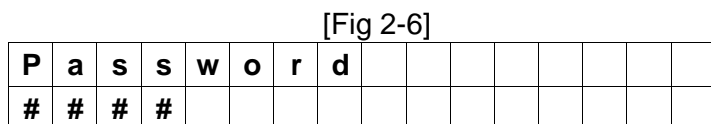

* In case of inputting the Password incorrectly,
 Press () key to the question " Data Save? " and then the RUN LED lights up (flash on).
 The LCD displays Fig 2-7 and it is not allowed to change any data.

[Fig 2-7]

P	a	s	s	w	o	r	d								
#	#	#	#												

d) How to input New Password

To change Password first input the existing Passord according to the procedure c).
 When the RUN LED blinks input new Password.

2.2) To move to Comm Channel mode as shown in Fig 2-8 press [FUNC] key.

Communication address can be set here from 1 through 255 by using (), () keys.
 It is required only for communication. Please set 000 in case of no communication.

[Fig 2-8]

C	o	m	m	.		C	h	a	n	n	e	l			
0	0	1													

* Changeable without inputing Password

2.3) To move to Comm Baud rate mode as shown in Fig 2-9 press [FUNC] key.

Communication speed can be set here among 2400, 4800, 9600 and 19200.

[Fig 2-9]

C	o	m	m	.		B	a	u	d		r	a	t	e	
	9	6	0	0											

* Changeable without inputing Password

* Factory default set is to 9600.

2.4) Press [FUNC] key to move to Exit mode.

[Fig 2-10]

	E	x	i	t											

To move to 2.SYS info menu press [ENT/RESET] key

3) SYS Info Menu

To move to 2. SYS info menu from 1. SYS DATA menu press [FUNC]

[Fig 3]

2	.	S	Y	S		I	n	f	o						

3.1) In case of DPR-SGR (DPR-211)

Pressing [ENT/RESET] key, LCD displays the model SGR as below.

[Fig 3-1]

R	e	l	a	y		I	n	f	o						
S	G	R													

3.2) Press [FUNC] key and rated zero-phase current 1.5 mA is displayed.

[Fig 3-2]

R	a	t	I	n	g		C	u	r	r					
1	.	5		m	A										

3.3) Press [FUNC] key and rated zero-phase voltage 190V is displayed.

[Fig 3-3]

R	a	t	I	n	g		V	o	l	t					
1	9	0		V											

3.4) Pressing [FUNC] key, SYS Model No is displayed as shown in Fig 3-4.

It is not allowed to change Model No.

[Fig 3-4]

S	Y	S		M	o	d	e	I		N	o	.			
D	P	R	-	2	1	1	S								

3.5) Pressing [FUNC] key, SYS Firmware No is displayed as shown in Fig 3-5.

It is not allowed to change the Number.

[Fig 3-5]

S	Y	S		F	I	r	m	w	a	r	e		N	o	.
S	G	R	_	V	x	_	x								

* x is Version No. of Firmware assigned by the maker.

3.6) Pressing [FUNC] key, SYS Serial ID with 8 digits is displayed as shown in Fig 3-6.

It is not changeable.

[Fig 3-6]

S	Y	S		S	e	r	I	a	I		I	D			
S	N	.	x	x	x	x	x	x	x	x	x				

* x is the No. of manufacture assigned by the maker.

3.7) Pressing [FUNC] key, Comm Module is displayed as shown in Fig 3-7.

It depends on the communication system and is not changeable.(Communication option)

[Fig 3-7]

C	o	m	m	.	M	o	d	u	l	e					
I	-	N	E	T											

(in case of I-NET)

3.8) Pressing [FUNC] key, Comm Version is displayed as shown in Fig 3-8 which is not changeable.

[Fig 3-8]

C	o	m	m	.		V	e	r	s	i	o	n		
x	x	x	x											

* x is the version no. of communication module assigned by the maker.

3.9) Press [FUNC] key to move to Exit mode.

[Fig 3-9]

	E	x	i	t										

To move to 3.FAULT Info menu press [ENT/RESET] key

4) FAULT Info Menu (**unchangeable**)

To move to 3.FAULT Info menu from previous menu press [FUNC]key.

[Fig 4]

3	.	F	A	U	L	T		I	n	f	o			

4.1) Pressing [ENT/RESET] key, the latest fault value of the zero-phase voltage is displayed as below. It is not changeable.

[Fig 4-1]

F	a	u	l	t		V	o							
		x	.	x	x	x	V							

* x is fault value.

4.2) Pressing [ENT/RESET] key, the latest fault value of the zero-phase current is displayed as below. It is not changeable.

[Fig 4-2]

F	a	u	l	t		I	o							
		x	.	x	x	x	m	A						

* x is fault value.

4.3) Pressing [FUN] key, the fault flag is displayed as below.

Reset to save the present fault data here. It's not allowed to alter the data after saving.

[Fig 4-3]

Ex.1) When tripped at zero-phase volt 100.9V and zero-phase current 5.4mA,

F	a	u	l	t		f	l	a	g	-	1			
	1	0	0	.	9	V				5	.	4	m	A

Ex.2) When tripped at zero-phase volt 100V and zero-phase current 5.04mA,

F	a	u	l	t		f	l	a	g	-	1			
	1	0	0	.	0	V				5	.	0	4	m A

4.4) Pressing [FUNC] key, Fig 4-4 displays the preceding fault record that is previous to the Fig4-3. It is not changeable.

[Fig 4-4]

Ex.) When tripped at zero-phase volt 99V and zero-phase current 5.04mA,

F	a	u	l	t		f	l	a	g	-	2			
		9	9	.	0	V				5	.	0	4	m A

4.5) Pressing [FUNC] key, Fig 4-5 displays the preceding fault record that is previous to the Fig4-4. It is not changeable.

[Fig 4-5]

Ex.) When tripped at zero-phase volt 100V and zero-phase current 5.40mA,

F	a	u	l	t		f	l	a	g	-	3			
	1	0	0	.	0	V				5	.	4	0	m A

4.6) Pressing [FUNC] key, Fig 4-6 displays the preceding fault record that is previous to the Fig4-5. It is not changeable.

[Fig 4-6]

Ex.) When tripped at zero-phase volt 100V and zero-phase current 3.40mA,

F	a	u	l	t		f	l	a	g	-	4			
	1	0	0	.	0	V				3	.	4	0	m A

4.7) Press [FUNC] key to move to Fault clear mode.

Here all records in FAULT Info Menu can be cleared by pressing [ENT/RESET] and () keys in order.

[Fig 4-7]

A	L	L		F	a	u	l	t		C	L	R		
C	L	E	A	R	=		E	N	T		K	e	y	

↓ [ENT/RESET] key

	D	a	t	a		S	a	v	e		?			
	Y	e	s	(U	P)		N	o	(D	N)

↓ () key

A	L	L		F	a	u	l	t		C	L	R		?
C	L	E	A	R	=		O	K		!				

4.8) Press [FUNC] key to move Exit mode.

[Fig 4-8]

	E	x	I	t											

To move to 4.MEASUREMENTS menu press [ENT/RESET] key

5) MEASUREMENTS Menu

To move to 4.MEASUREMENTS menu from previous menu press [FUNC]key.

[Fig 5]

4	.	M	E	A	S	U	R	E	M	E	N	T	S		

5.1) Pressing [ENT/RESET] key, the values of zero-phase voltage and current as follows.

[Fig 5-1]

V	o	I	t	a	g	e		V	o						
	x	.	x	x	x	V									

↓ [FUNC] key

C	u	r	r	e	n	t		I	o						
	x	.	x	x	x	m	A								

5.2) Press [FUNC] key to move to Exit mode.

[Fig 5-2]

	E	x	I	t											

To move to 5.SGR SETTING Menu press [ENT/RESET] key

6) SGR SETTING Menu (Password protected.)

To move to 5.SGR SETTING menu from previous menu press [FUNC]key.

[Fig 6]

5	.	S	G	R		S	E	T	T	I	N	G			

6.1) Press [ENT/RESET] key and Zero-phase current SET mode is displayed below.

This value can be set here from 0.9 to 5.4mA at the interval of 0.3mA.

[Fig 6-1]

I	o	-	S	E	T										
1	.	5		m	A										

* Press (), () keys to adjust the value of the current.

6.2) Press [ENT/RESET] key and Zero-phase voltage SET mode is displayed below.

This value can be set here from 4 to 76V at the interval of 4V.

[Fig 6-2]

V	o	-	S	E	T														
7	6		V																

Ex.) Changing the zero-phase voltage to 20V from 76V.

V	o	-	S	E	T														
7	6		V																

() key ↓

V	o	-	S	E	T														
2	0		V																

[ENT/RESET] key ↓

	D	a	t	a		S	a	v	e		?								
	Y	e	s	(U	P)		N	o	(D	N)					

() key ↓

V	o	-	S	E	T														
2	0		V																

6.3) Press [FUNC] key to move to TimeTap mode for setting Definite time.

Delay time can be set here from 0.1 to 10 sec at the interval of 0.1sec.

[Fig 6-3]

T	I	m	e	T	a	p													
0	.	1		S	e	c													

Ex.) Changing time set to 2.0 from 0.1

T	I	m	e	T	a	p													
0	.	1		S	e	c													

() key ↓

T	I	m	e	T	a	p													
2	.	0		S	e	c													

[ENT/RESET] key ↓

	D	a	t	a		S	a	v	e		?								
	Y	e	s	(U	P)		N	o	(D	N)					

() key ↓

T	I	m	e	T	a	p										
	2	.	0	S	e	c										

6.4) Press [FUNC] key to move to the mode to choose and set a datum phase angle out of 0°, 30°, 45°, 60°, 90°.

[Fig 6-4]

R	C	A														
	3	0	°													

Ex.) Changing the angle to 45° from 30°.

R	C	A														
	3	0	°													

() key ↓

R	C	A														
	4	5	°													

[ENT/RESET] key ↓

	D	a	t	a	S	a	v	e	?							
	Y	e	s	(U	P)	N	o	(D	N)			

() key ↓

R	C	A														
	4	5	°													

6.5) Pressing [FUNC] key, Exit mode displays as follows.

[Fig 6-5]

	E	x	I	t												

* Press [ENT/REST] key at this mode to move to DO SETTING menu.

7) Press [FUNC] key to move to 6.DO SETTING menu.

[Fig 7]

6	.		D	O	S	E	T	T	I	N	G					

7.1) Pressing [ENT/RESET] key, the present Relay output status are displayed as below.

[Fig 7-1]

D O	S t a t u s												
0 0 0													

* 3 digits represent 3 output relays and each digit shows the status of the corresponding Relay output. 0 indicates Relay off and 1 indicates On status.

Ex.) Chart below indicates only the 2nd Relay is on status.

D O	S t a t u s												
0 1 0													

* It is not latched but depends on the user's DO SETTING.

7.2) Output contacts configuration

The output contacts are fixed as shown in Fig 7-2.

[Fig 7-2]

Setting \ Contact		ForTRIP	for ALARM		
		TRIP	ALARM1	ALARM2	Use of contacts
TRIP RELAY	TRIP		X	X	TRIP
ALARM RELAY	ALM-TRIP	X		X	Alarm TRIP
	ALM-Sys Fail	X	X		Self-diagnosis Error

Note 1 : Factory set User set. If necessary. X : Not available

Note 2 : Do not use a ALARM Relay instead of TRIP(CB CONTOL) contacts.

Note 3 : If TRIP conatct is operated, the both status before and after event are stored.

7.3) Press [FUNC] key to move to the mode to set the function of TRIP Relay.

[Fig 7-3]

T R I P - S E T										
T R I P										

7.4) Press [FUNC] key to move to the mode to set the function of ALARM1 Relay.

[Fig 7-4]

A L A R M 1 - S E T										
A L M - T R I P										

7.5) Press [FUNC] key to move to the mode to set the function of ALARM2 Relay.

[Fig 7-5]

A L A R M 2 - S E T										
A L M - S y s F a i l										

7.6) Pressing [FUNC] key, Fig 7-6 displays. Press [ENT/RESET] key to move MENU Exit.

[Fig 7-6]

	E	x	I	t										

8) DATA displayed in the event of fault

When fault happens TRIP LED lights up and LCD Backlit and RUN LED are blinking. LCD displays the status as follows.

[Fig 8]

Ex.) In the case of Zero-phase voltage 100.0V and Zero-phase current 5.40mA

	□		F	a	u	I	t		T	r	i	p		□
	1	0	0	.	0	V			5	.	4	0	m	A

9) DATA displayed in the event of Self-diagnosis Error

Error signal is as shown in Fig 10.

[Fig 9]

S	Y	S		S	t	a	t	u	s					
E	R	R	0	R		x								

* In the event of happening more than one Error at the same time all Error codes are displayed. (Ex. ERROR 124)

3. Under and Overvoltage Relay (UVR & OVR)

3.1 Features and Specifications

Self-diagnostics

Fault recording

Sequence of Event(S.O.E)

High speed serial data communication

International standard applied

- IEC 255, IEC 1000-4, KEMC 1120

Type designation			DPR-311	DPR-411	
ANSI code			59 (27)	59/27	
Ratings	Voltage (Vn)		110V		
	Frequency (fn)		50/60Hz		
	Control power (Vx)		DC 110/125V (DC 85~150V)		
	Input burdens		0.5VA and below		
Relay elements			3phase Overvoltage protection (undervoltage protection) - Selecting UVR or OVR	3phase overvoltage protection (OVR) 3phase undervoltage protection (UVR)	
Setting range	Time delayed	OVR	121~165V/2V (110~150%)		
	Element	UVR	55~99V/2V (50~90%), No-voltage locking *1		
Operating time	Time delayed	Definite	0.05, 0.1~10seconds in a 0.1 step		
	Element				
Ancillary function			Self-diagnostics Fault records Sequence of Event (S.O.E)		
Communication mode			I-NET		
Display			Back-lit LCD(Dot Matrix)		
Output contacts	Switching capacity		Make 10A/250Vac, 0.5sec, Resistive Break 1A/250Vac 0.1PF		
	Constitution(6EA) *2		Trip Relay 2a, 1250VA and over Alarm Relay 3a System Fail Relay 1a		
	Type	at Trip operation		Trip Relay + Trip LED + Alarm Relay	
		self-diagnostics error		System Fail Relay+Alarm LED	
		at Normal		RUN LED	
Insulation Resistance			DC 500V 100MΩ and over		
Dielectric withstand			2kV (1kV) rms. and over for 1 minute		
High Voltage Impulse			5kV (3kV) peak and over applied for 1.2x50μs		
Overload capacity	Voltage circuit		Vn x 1.15 for 3 hours		
Temperature	Operating		-10 ~ 55		
	Storage		-20 ~ 70		
Humidity			80% RH (non-condensing)		
Applicable standard			IEC 255, IEC1000-4, KEMC 1120		
Weight			3.1kg		
Dimension			124mm (width), 177mm (height), 243mm (depth)		

Note : *1. No-voltage Lock : The Lock function can be selected not to be tripped when no input voltage appeared (20% and under of rated voltage)

*2. Each output relay can be set programmable according to the purpose of protection

3.2 Block Diagram

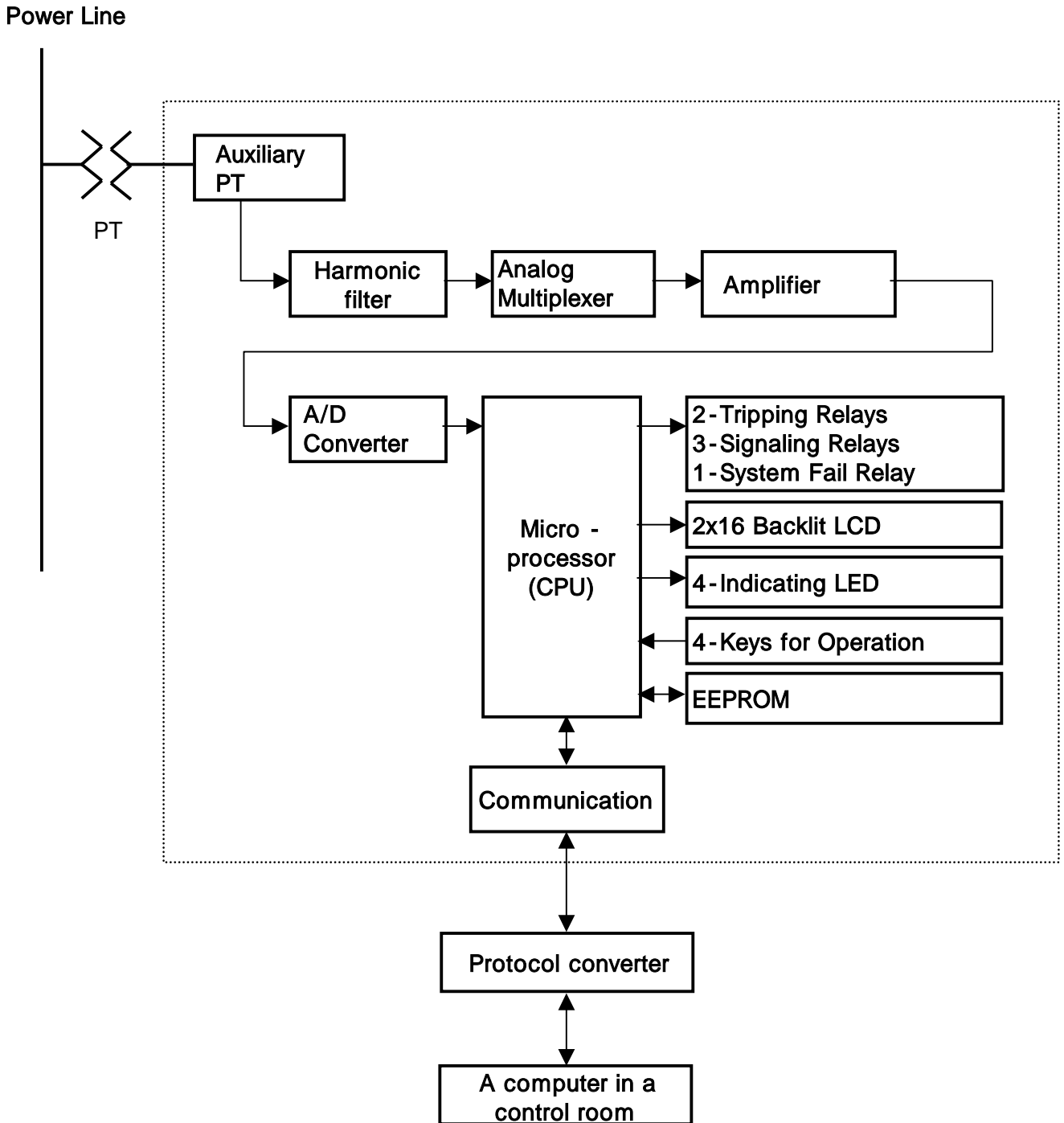

3.3 Application

Load Protection

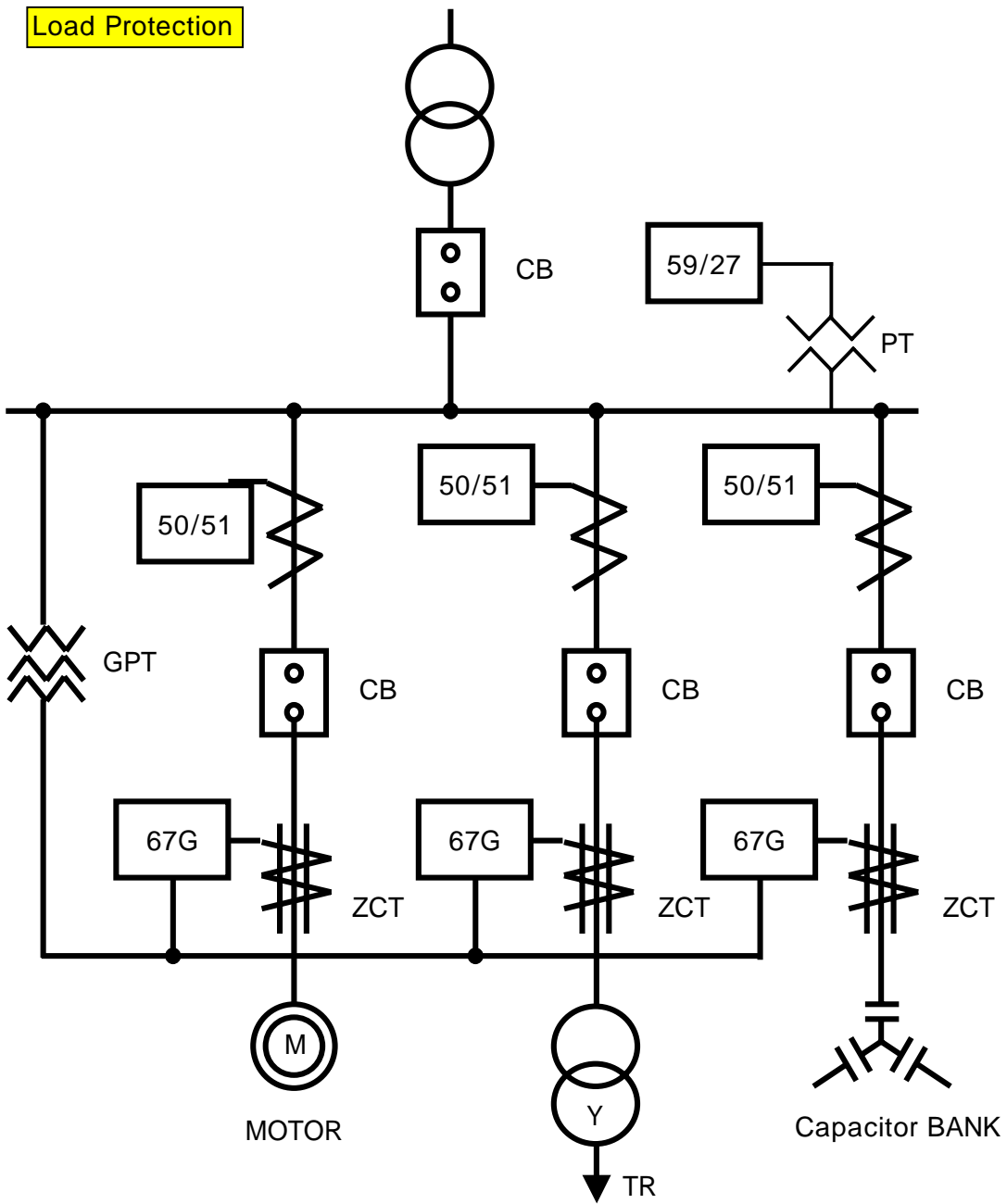

3.4 Wiring

3 phase 3 wire (Open Delta) system

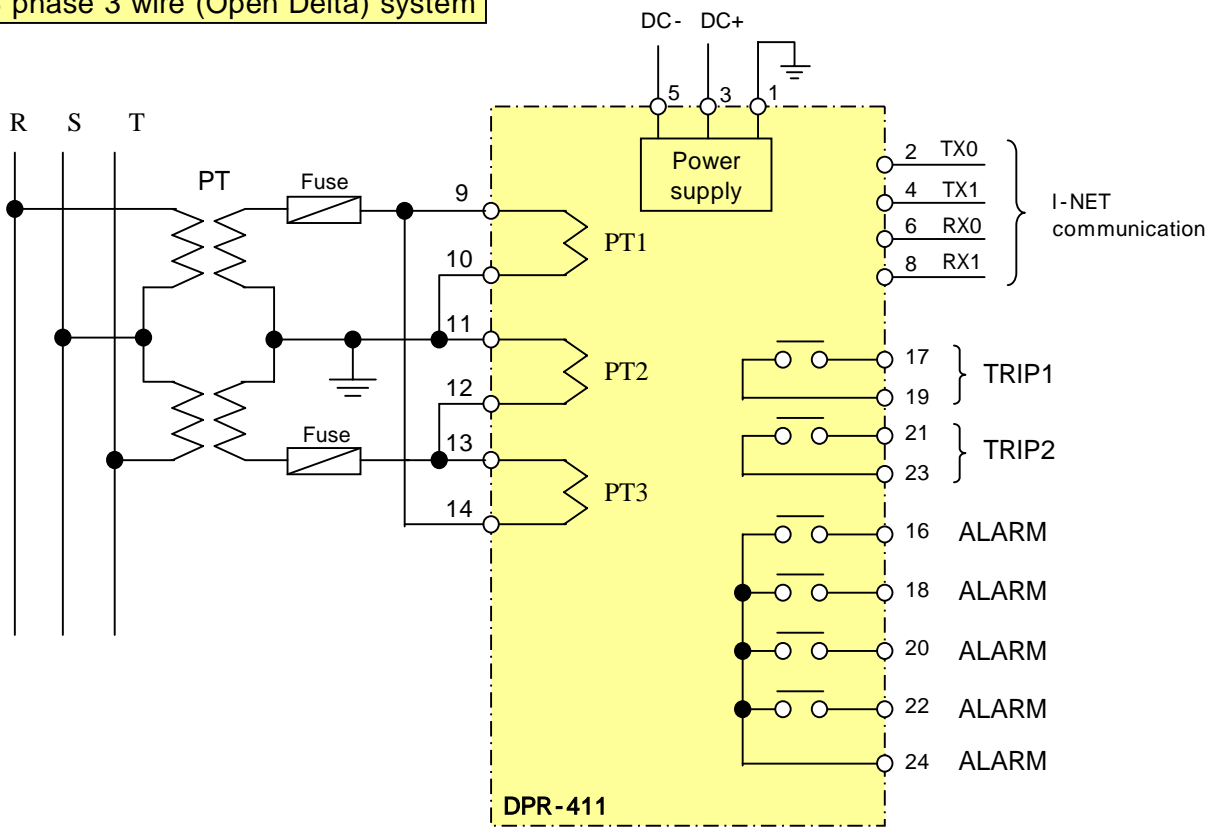

3 phase 3wire (Y-) system

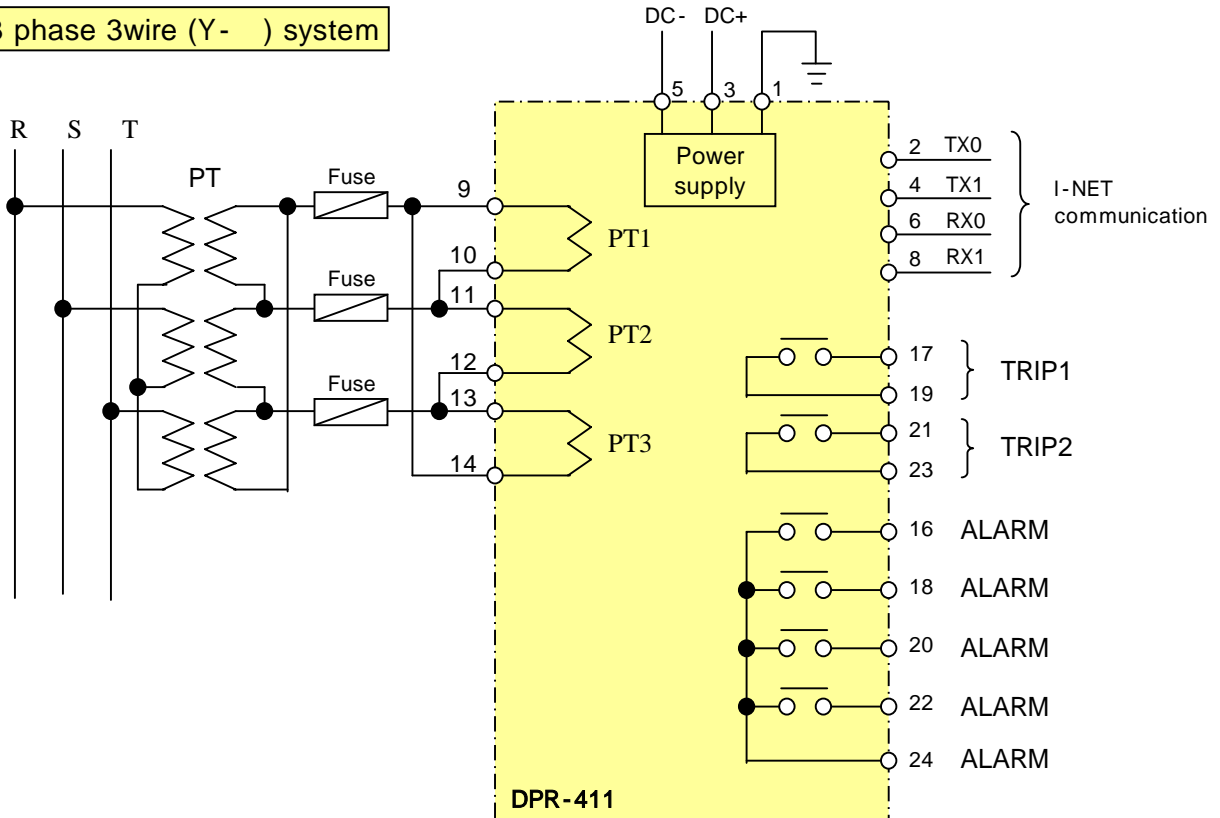

3 phase 4wire (Y-Y) system

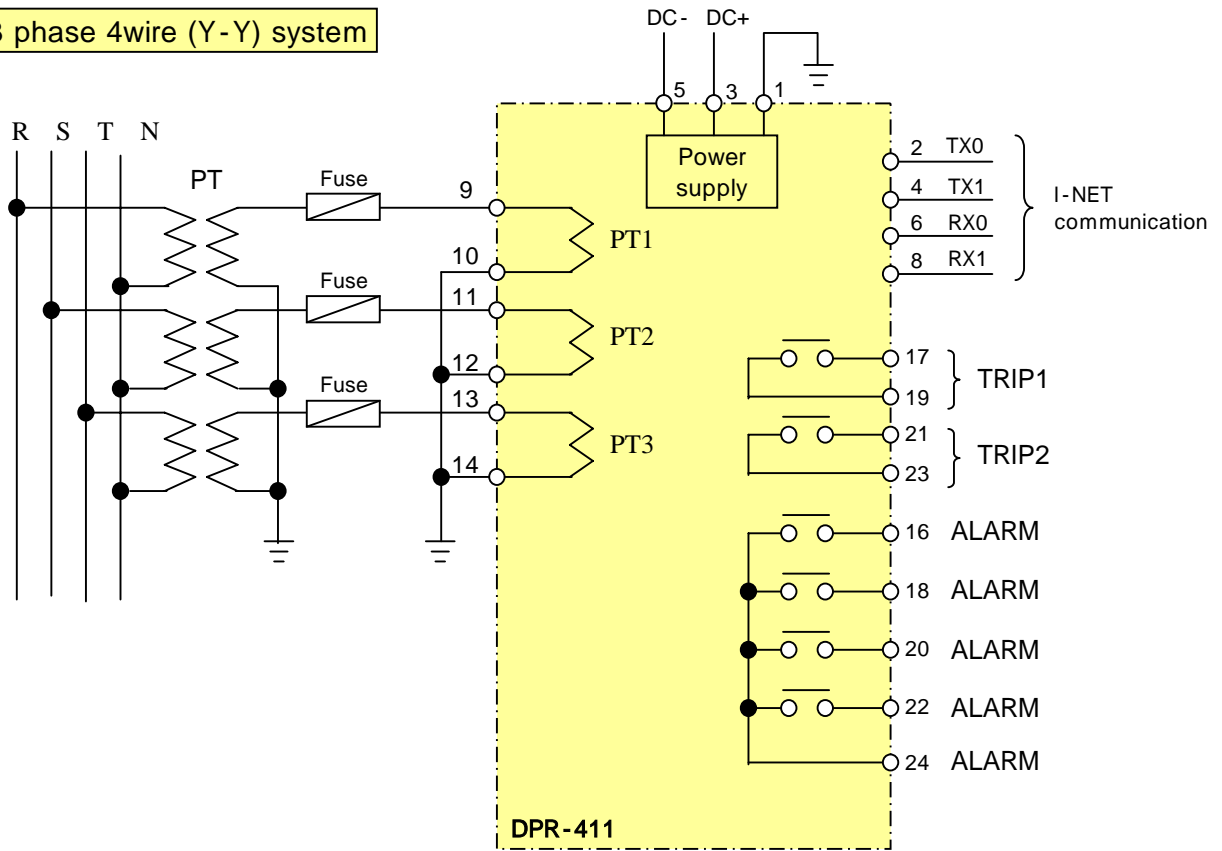

3.5 Output contacts

OVR(UVR) and OVR/UVR provide six(6) output contacts. Two of those are trip contacts to trip a circuit breaker and the others are for alarm signals. The operations of the contacts can be programmed according to user's requirements.

1) Trip contacts

Two trip contacts TRIP1 and TRIP2 are used to give a circuit breaker trip signals. Trip conditions such as common trip and 3-phase trip can be assigned to each contacts. Factory default setting is as follows.

	DPR-311	DPR-411
TRIP1	Common trip	OVR common trip
TRIP2	3-phase trip	UVR common trip

Contact rating : 250V AC 10A

Do not use trip contacts for the purpose of alarm conatcts

2) Alarm contacts

Four(4) alarm contacts are available here and are operated by the set conditions of users. These contacts are to give signals in the events of faults as follows.

- Trip alarm for common trip and phase(R,S,T) trip alarm
- Alarm for Self-diagnosis error
- Over voltage and under voltage alarm

Contact rating : 250V AC 5A

Do not use these contacts for the purpose of trip contacts.

3) Terminal Blocks

OVR(UVR)			
1	F.G	2	TX0
3	DC +	4	TX1
5	DC -	6	RX0
7		8	RX1
9	Rk	10	RI
11	Sk	12	SI
13	Tk	14	TI
15		16	ALARM1
17	TRIP1	18	ALARM2
19	TRIP1	20	ALARM3
21	TRIP2	22	ALARM4
23	TRIP2	24	ALARM COM

[DPR-311]

OVR/UVR			
1	F.G	2	TX0
3	DC +	4	TX1
5	DC -	6	RX0
7		8	RX1
9	Rk	10	RI
11	Sk	12	SI
13	Tk	14	TI
15		16	ALARM1
17	TRIP1	18	ALARM2
19	TRIP1	20	ALARM3
21	TRIP2	22	ALARM4
23	TRIP2	24	ALARM CON

[DPR-411]

All terminals of LG DPR series have the same grade of insulation and withstand current properties. Screws and Push-on blade type connectors can be used with them.

3.6 Front face configuration

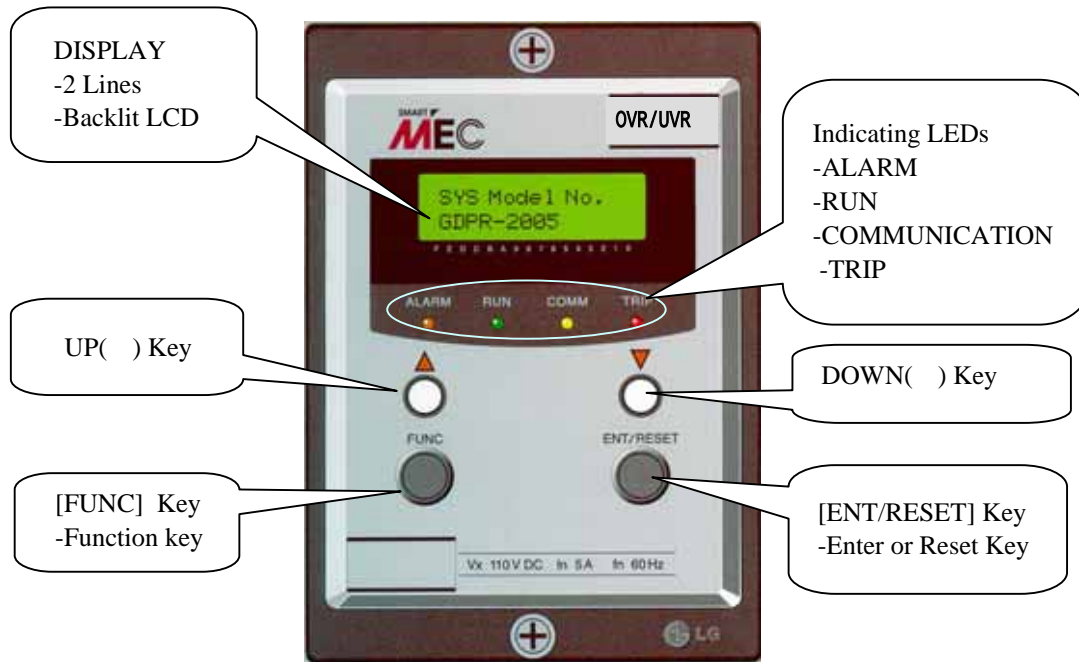

1. [FUNC] Function key to shift between menus.
2. [ENT/RESET] Enter or Reset key
Press to move to a upper or lower menu.
Press to select the data after changing before saving it.
In the event of fault it is used to reset.
3. [] Press to increase the value of the data to be changed.
Press in case of YES to the question asking "Data Save ?"
Press to shift between upper menus.
- [] Press to decrease the value of the data to be changed.
Press in case of NO to the question asking "Data Save ?"
Press to shift between upper menus.
4. [_ F] Keeping pressing the Function key until the initial menu displayed.
It makes the menu options 00 to return to the initial from any menu.
5. [_ E] Keeping pressing the Enter key to reset in the event of fault.

3.7 Operation manual

1) Turn on and then RUN LED lights up and LCD displays as below.

LCD displays [Fig 1-1] for 3 sec and then shows [Fig 1-2] or [Fig. 1-3].

[Fig. 1-1]

				L		G		I		S				
	D	I	g	I	t	a	I		R	e	I	a	y	

[Fig. 1-2]

Phase R			x	.	x	x	x	V			x	.	x	x	x	V	Phase S
Phase T			x	.	x	x	x	V					O	V	R		

It is normal running status. The RUN LED keeps lighting up.

Each phase voltage is displayed as x.xxx.

* In case of DPR-311 (OVR(UVR)) OVR or UVR is displayed according to user's choice.

[Fig. 1-3]

Phase R			x	.	x	x	x	V			x	.	x	x	x	V	Phase S	
Phase T			x	.	x	x	x	V			O	V	R	+	U	V	R	

* In case of DPR-411 (OVR/UVR) OVR+UVR is displayed.

2) SYS DATA Menu

SYS DATA menu is displayed as shown in Fig 2 by pressing [FUNC] key.

[Fig 2]

1	.	S	Y	S		D	A	T	A					

2.1) To move to Password mode as shown in Fig 2-1 press [ENT/RESET] key.

[Fig 2-1]

P	a	s	s	w	o	r	d							
#	#	#	#											

a) To change any data except Comm Channel(Communication Address) and Comm Baud rate (Communication speed) Password should be inputed.

b) The factory default set Password is 0123. In case of inputing new Password do not forget it. Contact LG if your Password has been forgotton.

c) How to input Password 0123

In the Password mode press () key once and then press [ENT/RESET] key.

O is inputed at the first digit as shown in Fig 2-2.

[Fig 2-2]

P	a	s	s	w	o	r	d							
#	#	#	#											



Press () key and [ENT/RESET] key in order

P	a	s	s	w	o	r	d								
0	#	#	#												

Press () key once and press [ENT/RESET] key in order.
 1 is inputed at the second digit as shown in Fig 2-3.

[Fig 2-3]

P	a	s	s	w	o	r	d								
0	#	#	#												



Press () key and [ENT/RESET] key in order

P	a	s	s	w	o	r	d								
0	1	#	#												

Press () key once and press [ENT/RESET] key in order.
 2 is inputed at the third digit as shown in Fig 2-4.

[Fig 2-4]

P	a	s	s	w	o	r	d								
0	1	#	#												



Press () key and [ENT/RESET] key in order

P	a	s	s	w	o	r	d								
0	1	2	#												

Press () key once and press [ENT/RESET] key in order.
 3 is inputed at the last digit as shown in Fig 2-5.

[Fig 2-5]

P	a	s	s	w	o	r	d								
0	1	2	#												



Press () key

P	a	s	s	w	o	r	d								
0	1	2	3												



Press [ENT/RESET] key

	D	a	t	a		S	a	v	e		?				
	Y	e	s	(U	P)		N	o	(D	N)	

* In case of inputing the correct Password
 Press () key to the question " Data Save? " and then the RUN LED blinks (flash on and off).
 The LCD displays Fig 2-6 and it is allowed to change and save new data.

[Fig 2-6]

P	a	s	s	w	o	r	d										
#	#	#	#														

* In case of inputting the Password incorrectly,
 Press () key to the question " Data Save? " and then the RUN LED lights up (flash on).
 The LCD displays Fig 2-7 and it is not allowed to change any data.

[Fig 2-7]

P	a	s	s	w	o	r	d										
#	#	#	#														

d) How to input New Password

To change Password first input the existing Passord according to the procedure c).
 When the RUN LED blinks input new Password.

2.2) To move to Comm Channel mode as shown in Fig 2-8 press [FUNC] key.
 Communication address can be set here from 1 through 255 by using (), () keys.
 It is required only for communication. Please set 000 in case of no communication.

[Fig 2-8]

C	o	m	m	.	C	h	a	n	n	e	l						
0	0	1															

* Changeable without inputting Password

2.3) To move to Comm Baud rate mode as shown in Fig 2-9 press [FUNC] key.
 Communication speed can be set here among 2400, 4800, 9600 and 19200.

[Fig 2-9]

C	o	m	m	.	B	a	u	d	r	a	t	e					
	9	6	0	0													

* Changeable without inputting Password
 * Factory default set is to 9600.

2.4) Press [FUNC] key to move to Exit mode.

[Fig 2-10]

	E	x	i	t													

To move to 2.SYS info menu press [ENT/RESET] key

3) SYS Info Menu

To move to 2. SYS info menu from 1. SYS DATA menu press [FUNC]

[Fig. 3]

2	.	S	Y	S	I	n	f	o									

3.1) In case of DPR-311 (OVR(UVR))

Pressing [ENT/RESET] key, LCD displays the selected model as follows.

It monitors and protects phases R, S, T and is optional between OVR and UVR.

[Fig. 3-1]

R	e	I	a	y		I	n	f	o					
O	V	R												

* OVR selected

3.2) In case of DPR-411 (OVR/UVR)

Pressing [ENT/RESET] key, LCD displays the model as follows.

It is the relay with the functions of OVR and UVR, and monitors and protects phases R, S, T.

[Fig. 3-2]

R	e	I	a	y		I	n	f	o					
O	V	R		+		U	V	R						

3.3) Pressing [FUNC]key, rated voltage,110V is displayed.

[Fig. 3-3]

R	a	t	I	n	g		V	o	l	t				
1	1	0	V											

Same application to DPR-311 and DPR-411.

No changing the value allowed.

3.4) Pressing [FUNC] key, SYS Model Numbers are displayed as shown in Fig 3-4.

Those are DPR-311 for OVR(UVR) and DPR-411 for OVR/UVR which are not changeable.

[Fig. 3-4]

S	Y	S		M	o	d	e	I		N	o	.		
D	P	R	-	3	1	1	S							

[DPR-OVR(UVR)]

S	Y	S		M	o	d	e	I		N	o	.		
D	P	R	-	4	1	1	S							

[DPR-OVR/UVR]

3.5) Pressing [FUNC] key, SYS Firmware No is displayed as shown in Fig 3-5.

The No. is OUVR_Vx_x for both DPR-311 and DPR-411 which is not changeable.

[Fig. 3-5]

S	Y	S		F	I	r	m	w	a	r	e		N	o	.
O	U	V	R	_	V	x	_	x							

* DPR-311 and DPR-411 use the same No.

* x is Version of Firmware assigned by the maker.

3.6) Pressing [FUNC] key, SYS Serial ID with 8 digits is displayed as shown in Fig 3-6.

It is not changeable.

[Fig. 3-6]

S	Y	S		S	e	r	I	a	I		I	D			
S	N	.	x	x	x	x	x	x	x	x					

* x is the No. of manufacture assigned by the maker.

3.7) Pressing [FUNC] key, Comm Module is displayed as shown in Fig 3-7.

It depends on the communication system and is not changeable.(Communication option)

[Fig 3-7]

C	o	m	m	.	M	o	d	u	l	e					
I	-	N	E	T											

(in case of I-NET)

3.8) Pressing [FUNC] key, Comm Version No. is displayed as shown in Fig 3-8

which is not changeable.

[Fig 3-8]

C	o	m	m	.		V	e	r	s	i	o	n			
x	x	x	x												

* x is the version No. of communication module assigned by the maker.

3.9) Press [FUNC] key to move to Exit mode.

[Fig 3-9]

	E	x	I	t											

To move to 3.FAULT Info menu press [ENT/RESET] key

4) FAULT Info Menu (**unchangeable**)

To move to 3.FAULT Info menu from previous menu press [FUNC]key.

[Fig 4]

3	.	F	A	U	L	T		I	n	f	o				

4.1) Pressing [ENT/RESET] key, the latest fault voltage of R phase is displayed as below.

It is not changeable.

[Fig 4-1]

F	a	u	l	t		V	1								
		x	.	x	x	x	V								

* x is fault voltage.

4.2) Pressing [ENT/RESET] key, the latest fault voltage of S phase is displayed as below.
It is not changeable.

[Fig. 4-2]

F	a	u	l	t		V	2								
		x	x	.	x	x	V								

* x is fault voltage.

4.3) Pressing [ENT/RESET] key, the latest fault voltage of T phase is displayed as below.
It is not changeable.

[Fig. 4-3]

F	a	u	l	t		V	3								
		x	x	.	x	x	V								

* x is fault voltage.

4.4) Pressing [FUN] key, the fault flag is displayed as below.
Reset to save the present fault data here.

[Fig. 4-4]

a) DPR-311 (OVR(UVR)) Model

Ex.1) When R, S and T phases are tripped in case of OVR set,

F	a	u	l	t		f	l	a	g	-	1				
		O	V	R	_	T	R	I	P	V	>	:	1	2	3

Ex.2) When R, S and T phases are tripped in case of UVR set,

F	a	u	l	t		f	l	a	g	-	1				
		U	V	R	_	T	R	I	P	V	<	:	1	2	3

b) DPR-411 (OVR/UVR) Model

Ex.1) When R, S, and T phases are tripped due to over voltage,

F	a	u	l	t		f	l	a	g	-	1				
		O	V	>	:	1	2	3		U	V	<	:		

Ex.2) When R, S, and T phases are tripped due to under voltage,

F	a	u	l	t		f	l	a	g	-	1				
		O	V	>	:					U	V	<	:	1	2

4.5) Pressing [FUNC] key, Fig 4-5 displays the preceding fault record that is previous to the Fig4-4.
It is not changeable.

[Fig. 4-5]

a) DPR-311 (OVR(UVR)) Model

Ex.1) When R and S phases are tripped in case of OVR set,

F	a	u	l	t		f	l	a	g	-	2				
O	V	R	_	T	R	I	P		V	>	:	1	2		

Ex.2) When R and S phases are tripped in case of UVR set,

F	a	u	l	t		f	l	a	g	-	2				
	U	V	R	_	T	R	I	P		V	<	:	1	2	

b) DPR-411 (OVR/UVR) Model

Ex.1) When R and S phases are tripped due to over voltage,

F	a	u	l	t		f	l	a	g	-	2				
O	V	>	:	1	2			U	V	<	:				

Ex.2) When R and S phases are tripped due to under voltage,

F	a	u	l	t		f	l	a	g	-	2				
O	V	>	:					U	V	<	:	1	2		

4.6) Pressing [FUNC] key, Fig 4-6 displays the preceding fault record that is previous to the Fig4-5. It is not changeable.

[Fig. 4-6]

a) DPR-311 (OVR(UVR)) Model

Ex.1) When R and T phases are tripped in case of OVR set,

F	a	u	l	t		f	l	a	g	-	3				
	O	V	R	_	T	R	I	P		V	>	:	1	3	

Ex.2) When R and T phases are tripped in case of UVR set,

F	a	u	l	t		f	l	a	g	-	3				
	U	V	R	_	T	R	I	P		V	<	:	1	3	

b) DPR-411 (OVR/UVR) Model

Ex.1) When R and T phases are tripped due to over voltage,

F	a	u	l	t		f	l	a	g	-	3				
O	V	>	:	1	3			U	V	<	:				

Ex.2) When R and T phases are tripped due to under voltage,

F	a	u	l	t		f	l	a	g	-	3				
O	V	>	:					U	V	<	:	1	3		

4.7) Pressing [FUNC] key, Fig 4-7 displays the preceding fault record that is previous to the Fig4-6. It is not changeable.

[Fig. 4-7]

a) DPR-311 (OVR(UVR)) Model

Ex.1) When S and T phases are tripped in case of OVR set,

F	a	u	l	t		f	l	a	g	-	4				
	O	V	R	_	T	R	I	P		V	>	:	2	3	

Ex.2) When S and T phases are tripped in case of UVR set,

F	a	u	l	t		f	l	a	g	-	4				
	U	V	R	_	T	R	I	P		V	<	:	2	3	

b) DPR-411 (OVR/UVR) Model

Ex.1) When S and T phases are tripped due to over voltage,

F	a	u	l	t		f	l	a	g	-	4				
	O	V	>	:	2	3			U	V	<	:			

Ex.2) When S and T phases are tripped due to under voltage,

F	a	u	l	t		f	l	a	g	-	4				
	O	V	>	:					U	V	<	:	2	3	

4.8) Press [FUNC] key to move to Fault clear mode.

Here all records in FAULT Info Menu can be cleared by pressing [ENT/RESET] and () keys in order.

[Fig. 4-8]

A	L	L		F	a	u	l	t		C	L	R			
C	L	E	A	R	=		E	N	T		K	e	y		

↓ ENT/RESET key

	D	a	t	a		S	a	v	e		?				
	Y	e	s	(U	P)		N	o	(D	N)	

↓ () key

A	L	L		F	a	u	l	t		C	L	R		?	
C	L	E	A	R	=		O	K		!					

4.9) Press [FUNC] key to move Exit mode.

[Fig 4-9]

	E	x	i	t											

To move to 4.MEASUREMENTS menu press [ENT/RESET] key

5) MEASUREMENTS Menu

To move to 4.MEASUREMENTS menu from previous menu press [FUNC]key.

[Fig. 5]

4	.	M	E	A	S	U	R	E	M	E	N	T	S		

5.1) Pressing [ENT/RESET] key, the secondary voltage of the CT of each phase is displayed as shown in Fig5-1. The voltage of each phase can be calculated from this displayed volts and PT ratio.

[Fig. 5-1]

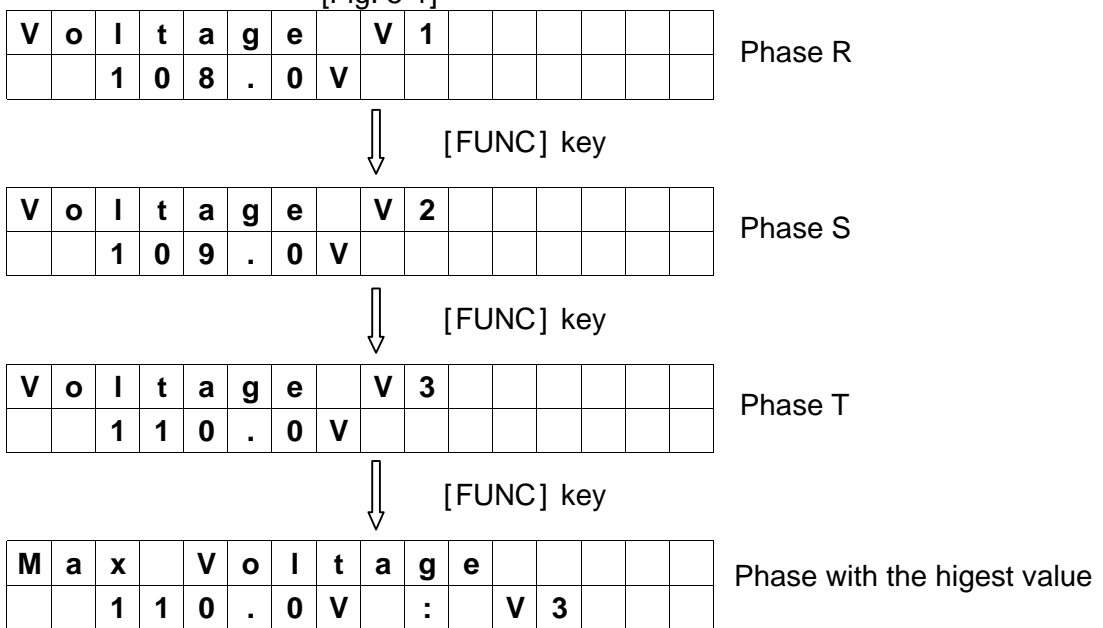

5.2) Calculation of voltage of each phase

Ex.) If PT ration is 22900 :110V and the displayed volt of phase T is 110V, the volt of phase T is 22900V.

5.3) Press [FUNC] key to move to Exit mode.

To move to 5.OVR SETTING menu press [ENT/RESET] key

[Fig. 5-2]

	E	x	i	t											

6) DPR-311 (OVR(UVR)) SETTING Menu (Password protected)

6.1) Setting to OVR

Pressing [FUNC] key, 5.OVR SETTING Menu is displayed as follows.

[Fig. 6]

5	.	O	V	R		S	E	T	T	I	N	G			

- a) Pressing [ENT/RESET] key, voltage setting mode is displayed as follows.
 The voltage can be set from 121 to 165 V at the interval of 2 V.

[Fig. 6-1]

T	D	-	S	E	T										
1	2	1			V										

*Use (), () keys to increase or decrease the value.

- b) Press [FUNC] key to move to Trip time setting mode.
 The trip time options are 0.05 and 0.1 to 10 at the interval of 0.1sec.

[Fig. 6-2]

T	D	-	T	I	m	e	T	a	p						
	0	.	0	5	S	e	c								

Ex.) How to change the time set to 10 sec from 0.05sec

T	D	-	T	I	m	e	T	a	p						
	0	.	0	5	S	e	c								

() key ↓

T	D	-	T	I	m	e	T	a	p						
	1	0	.	0	0	S	e	c							

[ENT/RESET] key ↓

	D	a	t	a		S	a	v	e	?					
	Y	e	s	(U	P)		N	o	(D	N)	

() key ↓

T	D	-	T	I	m	e	T	a	p						
	1	0	.	0	0	S	e	c							

[FUNC] key ↓

	E	x	I	t											

- c) Press [ENT/RESET] key to move to 6.DO SETTING Menu.

6.2) Setting to UVR

Pressing [FUNC] key, 5.UVR SETTING Menu is displayed as follows.

[Fig. 6-3]

5	.	U	V	R		S	E	T	T	I	N	G			

a) Pressing [ENT/RESET] key, voltage setting mode is displayed as follows.

The voltage can be set from 55 to 99 V at the interval of 2 V.

[Fig. 6-4]

T	D	-	S	E	T										
	5	5			V										

*Use (), () keys to increase or decrease the value.

b) Press [FUNC] key to move to Trip time setting mode.

The trip time options are 0.05 and 0.1 to 10 at the interval of 0.1sec.

[Fig. 6-5]

T	D	-	T	I	m	e	T	a	p						
	0	.	0	5	S	e	c								

* Refer to the Fig 6.2 for changing it's value.

c) Press [FUNC] key and the mode to select between TRIP LOCK and TRIP UNLOCK is displayed.

This function is applied in the event the input voltages of R, S and T phases are dropped under 20V.

[Fig. 6-6]

V	o	I	t	a	g	e		a	b	s	e	n	c	e	
T	R	I	P					L	o	c	k				

Ex.) From TRIP LOCK to UNLOCK

V	o	I	t	a	g	e		a	b	s	e	n	c	e	
T	R	I	P					L	o	c	k				

() key ↓

V	o	I	t	a	g	e		a	b	s	e	n	c	e	
T	R	I	P		U	n	L	o	c	k					

[ENT/RESET] key ↓

	D	a	t	a		S	a	v	e		?					
	Y	e	s		(U	P)		N	o		(D	N)

() key ↓

V	o	I	t	a	g	e		a	b	s	e	n	c	e	
T	R	I	P		U	n	L	o	c	k					

[FUNC] key ↓

	E	x	I	t											

d) Press [ENT/RESET] key to move to 6.DO SETTING Menu.

7) DPR-411 (OVR/UVR) SETTING Menu (Password protected)

Pressing [FUNC] key, 5.OVR SETTING Menu is displayed as follows.

[Fig. 7]

5	.	O	V	R		S	E	T	T	I	N	G			

7.1) Pressing [ENT/RESET] key, voltage setting mode is displayed as follows.

The voltage can be set from 121 to 165 V at the interval of 2 V.

[Fig. 7-1]

T	D	-	S	E	T										
1	2	1			V										

*Use (), () keys to increase or decrease the value.

7.2) Press [FUNC] key to move to Trip time setting mode.

The trip time options are 0.05 and 0.1 to 10 at the interval of 0.1sec.

[Fig. 7-2]

T	D	-	T	I	m	e	T	a	p						
	0	.	0	5	S	e	c								

Ex.) Chaning trip time to 10 from 0.05sec

T	D	-	T	I	m	e	T	a	p						
	0	.	0	5	S	e	c								

() key ↓

T	D	-	T	I	m	e	T	a	p						
1	0	.	0	0	S	e	c								

[ENT/RESET] key ↓

	D	a	t	a		S	a	v	e		?				
	Y	e	s	(U	P)		N	o	(D	N)	

() key ↓

T	D	-	T	I	m	e	T	a	p						
1	0	.	0	0	S	e	c								

7.3) Press [FUNC] key to move to Exit Mode or press [ENT/RESET] key to move to 6. UVR SETTING Menu as follows.

[Fig. 7-3]

6	.	U	V	R		S	E	T	T	I	N	G			

7.4) Pressing [ENT/RESET] key, voltage setting mode is displayed as follows.

The voltage can be set from 55 to 99 V at the interval of 2 V.

[Fig. 7-4]

T	D	-	S	E	T										
	5	5			V										

*Use (), () keys to increase or decrease the value.

7.5) Press [FUNC] key to move to Trip time setting mode.

The trip time options are 0.05 and 0.1 to 10 at the interval of 0.1sec.

[Fig. 7-5]

T	D	-	T	I	m	e	T	a	p						
	0	.	0	5	S	e	c								

* Refer to the Fig 7.2 for changing it's value.

7.6) Press [FUNC] key and the mode to select between TRIP LOCK and TRIP UNLOCK is displayed. This function is applied in the event the input voltages of R, S and T phases are dropped under 20V.

[Fig. 7-6]

V	o	I	t	a	g	e		a	b	s	e	n	c	e	
T	R	I	P					L	o	c	k				

Ex.) From TRIP LOCK to UNLOCK

V	o	I	t	a	g	e		a	b	s	e	n	c	e	
T	R	I	P					L	o	c	k				

() key ↓

V	o	I	t	a	g	e		a	b	s	e	n	c	e	
T	R	I	P		U	n	L	o	c	k					

[ENT/RESET] key ↓

	D	a	t	a		S	a	v	e		?				
	Y	e	s	(U	P)		N	o	(D	N)	

() key ↓

V	o	I	t	a	g	e		a	b	s	e	n	c	e	
T	R	I	P		U	n	L	o	c	k					

[FUNC] key ↓

	E	x	I	t											

7.7) Press [ENT/RESET] key to move to 7.DO SETTING menu.

8) DPR-311 (OVR(UVR)) DO SETTING Menu (Password protected)

Press [FUNC] key to move to 6.DO SETTING menu.

[Fig. 8]

6	.		D	O		S	E	T	T	I	N	G		

8.1) Pressing [ENT/RESET] key, the present Relay output status are displayed as below.

[Fig. 8-1]

D	O		S	t	a	t	u	s						
0	0	0	0	0	0									

* 6 digits represent 6 output relays and each digit shows the status of the corresponding Relay output. 0 indicates Relay off and 1 indicates On status.

Ex.) Chart below indicates only the 4th Relay is on status.

D	O		S	t	a	t	u	s						
0	0	0	1	0	0									

* It is not latched but depends on the user's DO SETTING.

8.2) Output contacts configuration

The output contacts are designed to be set by user's requirements as shown in Fig 8-2.

[Fig. 8-2]

Setting \ contact		For TRIP		For ALARM				Use of contacts
		TRIP1	TRIP2	ALARM1	ALARM2	ALARM3	ALARM4	
TRIP RELAY	TRIP			X	X	X	X	Fault in one or more phase
	TRIP-3 Phase			X	X	X	X	Fault in all three phases
ALARM RELAY	ALM-TRIP	X	X				X	Trip in one or more phase
	ALM-3 Phase	X	X				X	Three phase TRIP
	ALM-V1	X	X				X	R phase TRIP
	ALM-V2	X	X				X	S phase TRIP
	ALM-V3	X	X				X	T phase TRIP
	ALM-Sys Fail	X	X	X	X	X		Self-diagnosis Error
	PICK-UP	X	X				X	Overload signal
NO USE	X	X				X	No use	

Note 1 : Factory set User set. If necessary. X : Not available

Note 2 : Do not use ALARM Relays instead of TRIP(CB CONTROL) contacts.

Note 3 : If TRIP1 and TRIP2 contacts are operated, the both status before and after event are stored.

Note 4 : DPR-311 is to be set to OVR or UVR. Factory default set is to UVR.

Note 5 : DPR-411 is the multi-functional relay with OVR and UVR.

TRIP1 is the trip contact for OVR and TRIP2 for UVR.

Those can be set to TRIP or TRIP-3Phase by requirement.

8.3) Press [FUNC] key to move to the mode to set the function of Relays.

a) DPR-311 (OVR(UVR))

To set the functions of TRIP1 Relay and TRIP2 Relay press [FUNC] key.

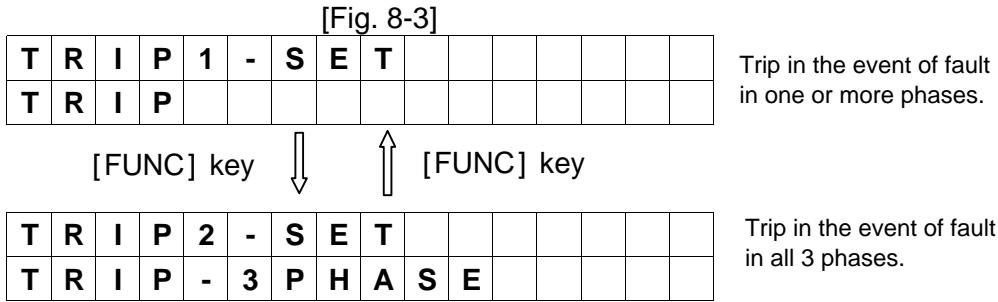

To set the function of ALARM1 Relay press [FUNC] key.

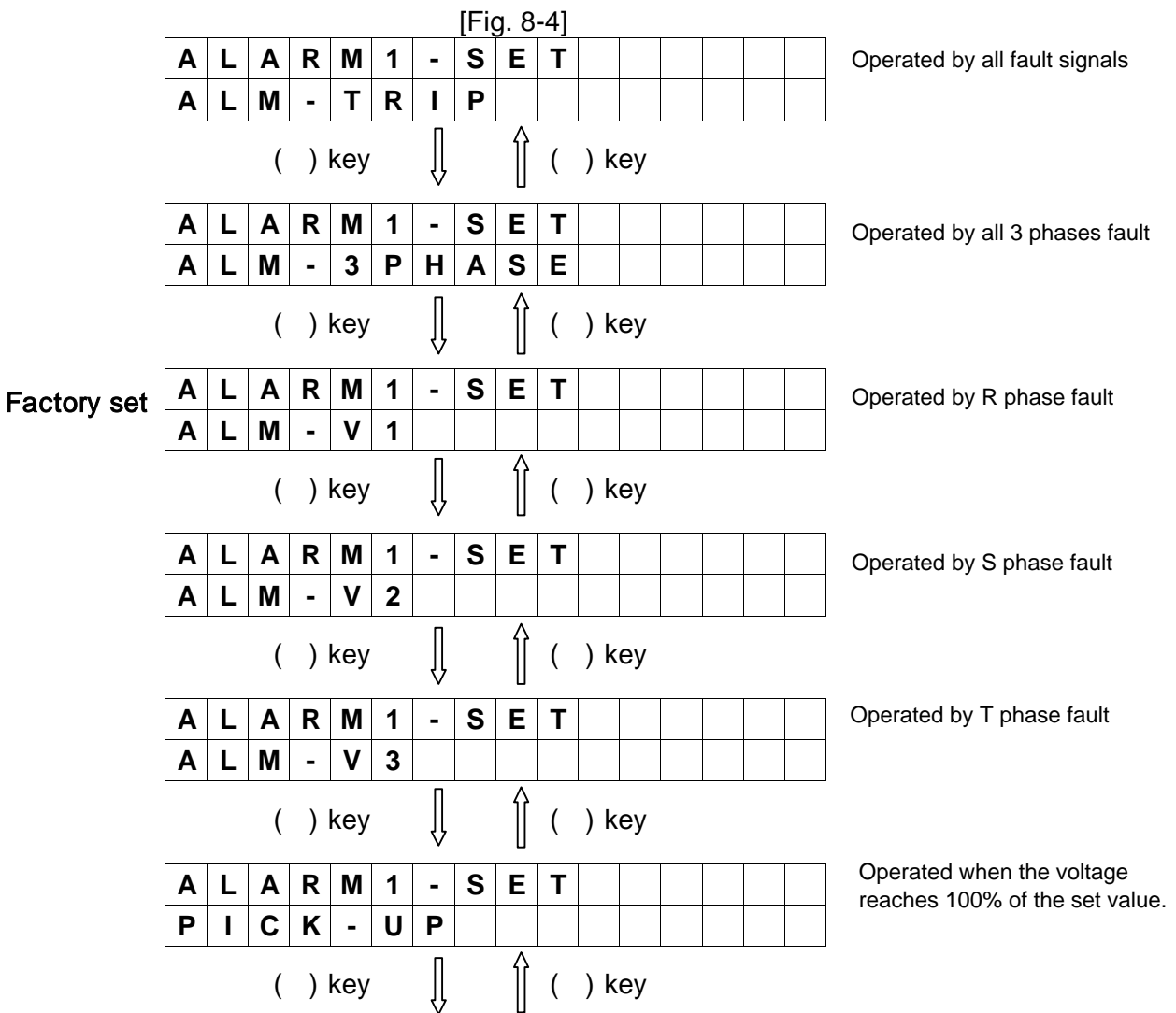

A	L	A	R	M	1	-	S	E	T					
N	O		U	S	E									

Alarm1 Relay is not in use.

Ex.) How to change to PICK-UP from ALARM-V1.

Factory

A	L	A	R	M	1	-	S	E	T					
A	L	M	-	V	1									

Operated by R phase fault

() key ↓ ↑ () key

A	L	A	R	M	1	-	S	E	T					
P	I	C	K	-	U	P								

Operated when the voltage reaches 100% of the set value.

[ENT/RESET] key ↓

	D	a	t	a		S	a	v	e	?				
	Y	e	s	(U	P)		N	o	(D	N)

() key ↓

A	L	A	R	M	1	-	S	E	T					
P	I	C	K	-	U	P								

Operated when the voltage reaches 100% of the set value.

Press [FUNC] key to move to the modes for setting the functions of ALARM2, ALARM3. Refer to the above process for detail.

Press [FUNC] key to move to ALARM4-SET mode. It is only for ALM-SysFail that operates in the event of Self-diagnosis Error.

b) DPR-411 (OVR/UVR)

To set the functions of TRIP1 Relay press [FUNC] key. It is applied in the case of OVR related.

[Fig. 8-5]

T	R	I	P	1	-	S	E	T						
O	V	R	_	T	R	I	P							

Trip in the event of fault in one or more phases.

() key ↓ ↑ () key

T	R	I	P	1	-	S	E	T						
O	V	R	_	T	R	I	P	-	3	P	H	A	S	E

Trip in the event of fault in all 3 phases.

To set the functions of TRIP2 Relay press [FUNC] key. It is applied in the case of UVR related.

[Fig. 8-6]

T	R	I	P	2	-	S	E	T						
U	V	R	_	T	R	I	P							

Trip in the event of fault in one or more phases.

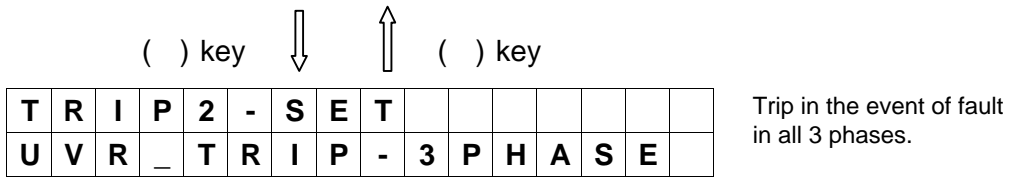

To set the function of ALARM1 Relay press [FUNC] key.

[Fig. 8-7]

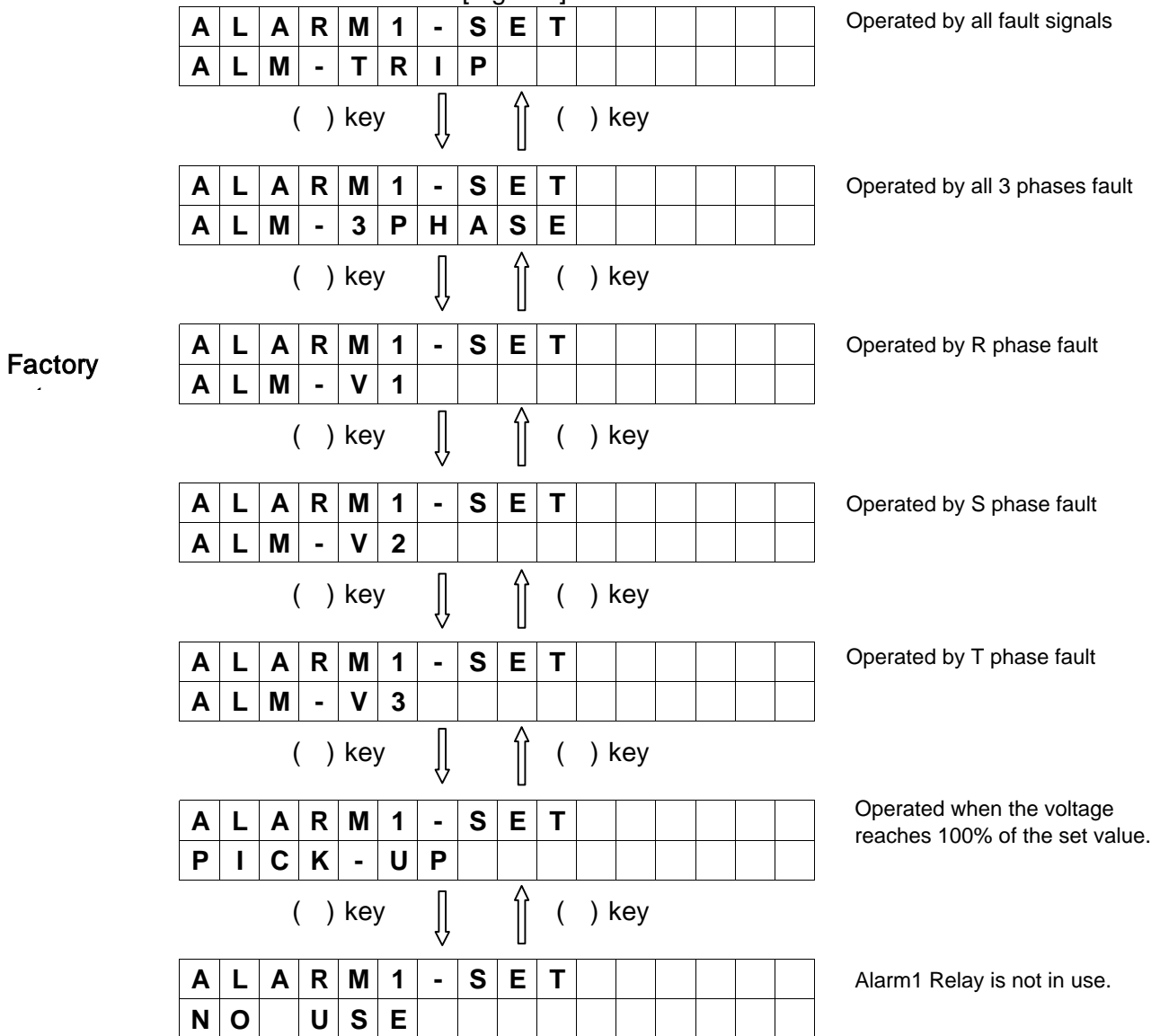

Ex.) How to change to ALARM-TRIP from ALARM-V1.

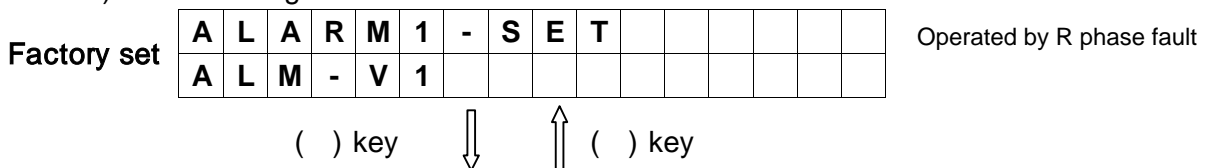

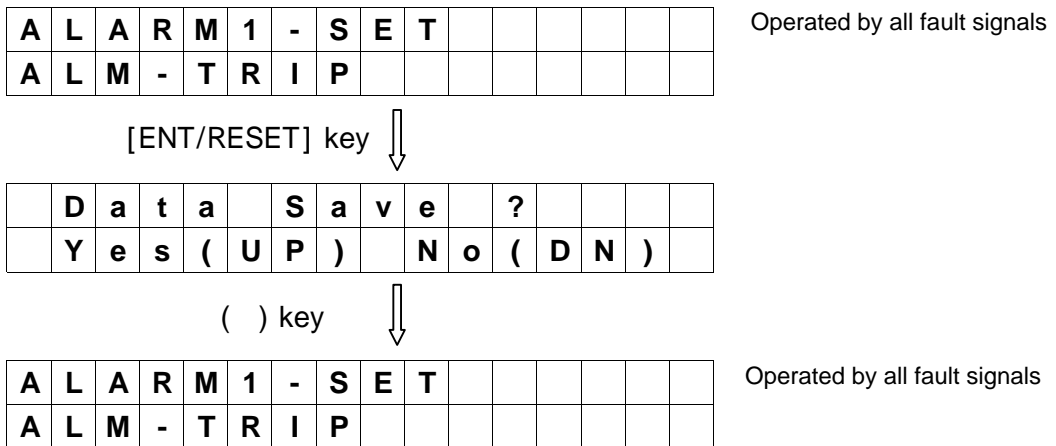

Press [FUNC] key to move to the modes for setting the functions of ALARM2, ALARM3. Refer to the above process for detail.

Press [FUNC] key to move to ALARM4-SET mode. It is only for ALM-SysFail that operates in the event of Self-diagnosis Error.

9) DATA displayed in the event of fault

When fault happens **TRIP LED lights up and LCD Backlit and RUN LED are blinking.** LCD displays the status as follows.

a) DPR-311 (OVR(UVR))

[Fig. 9]

Ex. 1) In the event of Phase R trip when OVR selected.

	□		F	a	u	l	t		T	r	i	p		□
	O	V	R	-	T	R	I	P		V	>	:	1	

Ex. 2) In the event of the trip of all 3 phases when OVR selected.

	□		F	a	u	l	t		T	r	i	p		□	
	O	V	R	-	T	R	I	P		V	>	:	1	2	3

Ex. 3) In the event of Phase S trip when UVR selected.

	□		F	a	u	l	t		T	r	i	p		□
	U	V	R	-	T	R	I	P		V	<	:	2	

Ex. 2) In the event of the trip of R and T phases when UVR selected.

	□		F	a	u	l	t		T	r	i	p		□
	U	V	R	-	T	R	I	P		V	<	:	1	3

b) DPR-411 (OVR/UVR)

[Fig. 9-1]

Ex.1) In the event of trip of phase R from OVR

	□		F	a	u	l	t		T	r	i	p		□	
O	V	>	:	1					U	V	<	:			

Ex.2) In the event of trip of all 3 phases from OVR

	□		F	a	u	l	t		T	r	i	p		□	
O	V	>	:	1	2	3			U	V	<	:			

Ex.3) In the event of trip of phase S from UVR

	□		F	a	u	l	t		T	r	i	p		□	
O	V	>	:						U	V	<	:	2		

Ex.4) In the event of trip of phases R and T from UVR

	□		F	a	u	l	t		T	r	i	p		□	
O	V	>	:						U	V	<	:	1	3	

10) DATA displayed in the event of Self-diagnosis Error

Error signal is as shown in Fig 10.

[Fig 10]

S	Y	S		S	t	a	t	u	s						
E	R	R	0	R	x										

* In the event of happening more than one Error at the same time all Error codes are displayed.
(Ex. ERROR 124)

4. Over Voltage Ground Relay(OVGR : Earth Fault Overvoltage Protection)

4.1 Features and Specifications

Self-diagnostics	Standard inverse time
Fault recording	Very inverse time
Sequence of Event (S.O.E)	Extremely inverse time
High speed serial data communication	Long inverse time
International standard applied	Definite time
- IEC 255, IEC 1000-4, KEMC 1120	

Type designation		DPR-511	
ANSI code		64	
Ratings	Voltage (Von)	190V or 190√3 V	
	Frequency (fn)	50/60Hz	
	Control power (Vx)	DC 110/125V (DC 85-150V)	
	Input burden	0.5VA and below	
Relay elements		Over Voltage Ground Protection (Earth fault overvoltage protection/OVGR)	
Setting range	Time delayed setting	20~76/2V (10.5~40%)	
	Instantaneous setting	20~76/2V (10.5~40%), Lock	
Operating time	Time delayed element	Inverse	Standard inverse, Very inverse, Extremely inverse 0.05~1.00sec in a 0.1sec step
		Definite time	0.1~10sec in a 0.1sec step
	Instantaneous element	Definite time	within 35msec
Ancillary function		Self-diagnostics Fault recording Sequence of Event (S.O.E)	
Communication mode		I-NET	
Display		Back-lit LCD (Dot Matrix)	
Output contacts	Switching capacity		Make 10A/250Vac, 0.5sec, Resistive Break 1A/250Vac 0.1PF
	Constitution (3EA)		Trip Relay 1a, 1250VA and over Alarm Relay 1a System Fail Relay 1a
	Type	at Trip operation	Trip Relay + Trip LED + Alarm Relay
		self-diagnostics error	System Fail Relay+Alarm LED
	at Normal	RUN LED	
Insulation Resistance		DC 500V 100MΩ and over	
Dielectric withstand		2kV (1kV) rms. and over for 1 minute	
High Voltage Impulse		5kV (3kV) peak and over applied for 1.2x50 μs	
Overload capacity	Voltage circuit	Vn x 1.15 for 3 hours	
Temperature	Operating	-10 ~ 55	
	Storage	-20 ~ 70	
Humidity		80% RH (Non-condensing)	
Applicable standard		IEC 255, IEC1000-4, KEMC 1120	
Weight		2.8kg	
Dimension		124mm (width), 177mm (height), 243mm (depth)	

4.2 Block Diagram

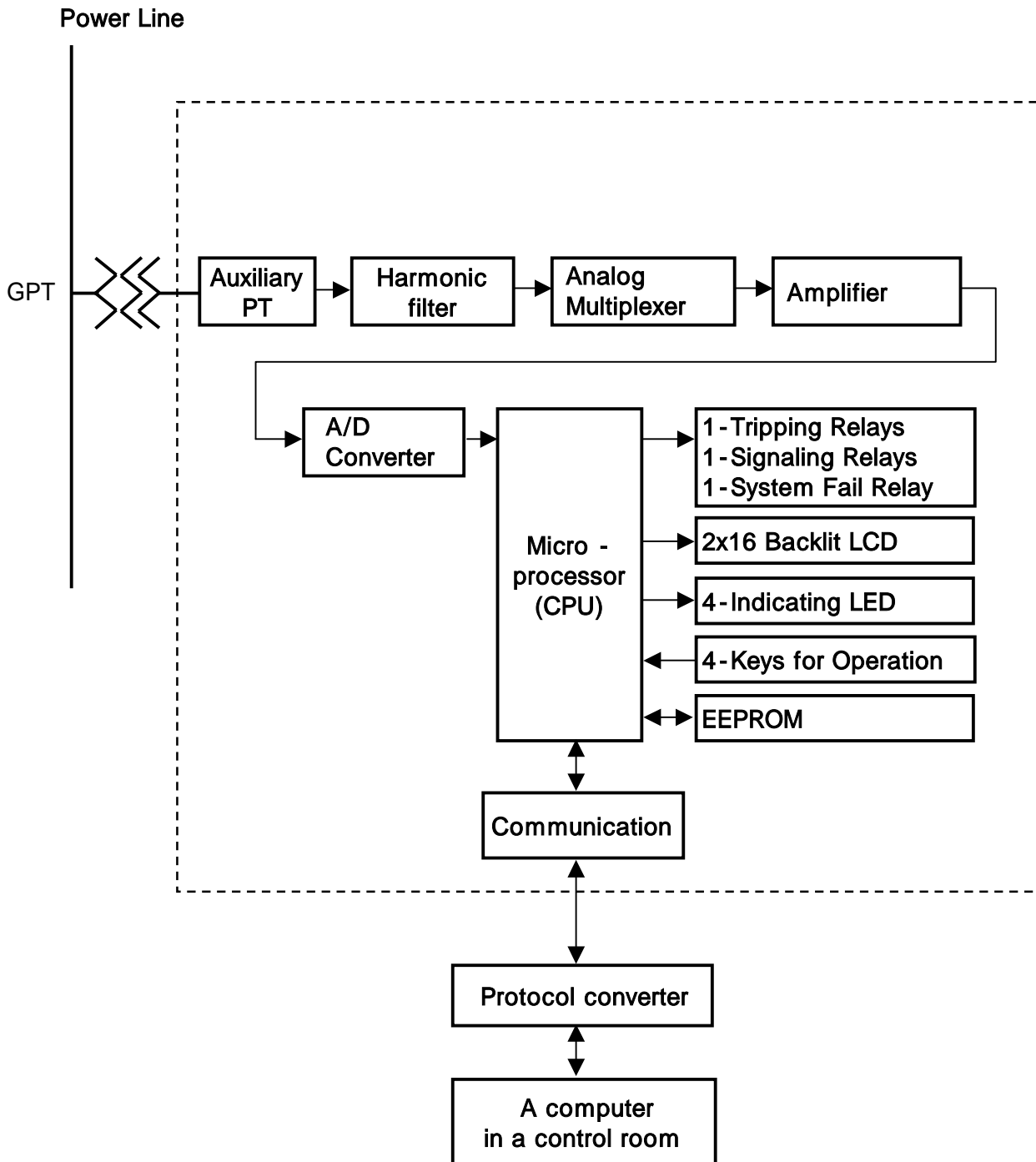

4.3 Application

Feeder Protection

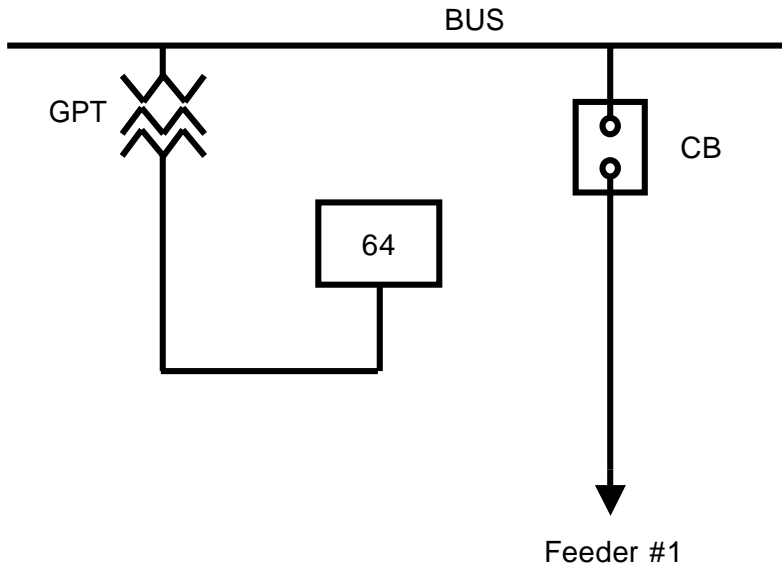

4.4 Wiring

3phase 3 wire non-grounded system

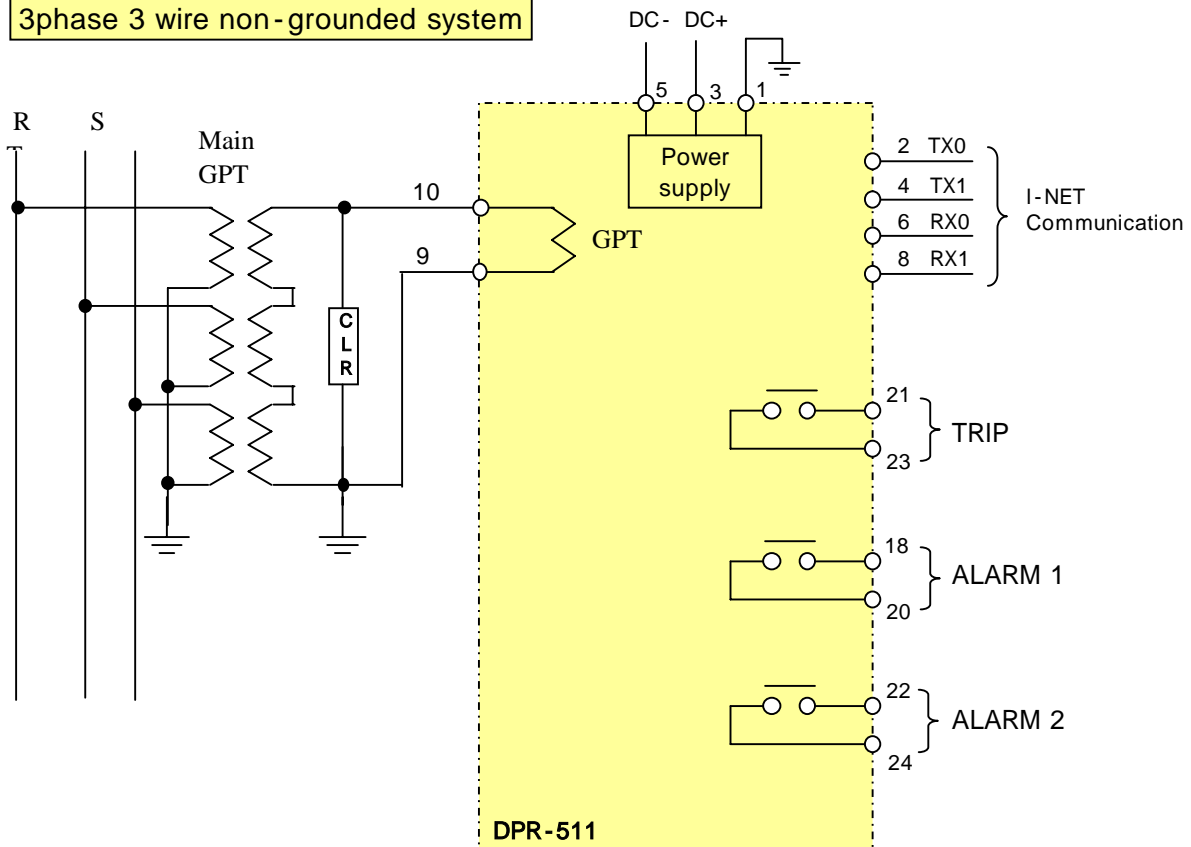

4.5 Output contacts

OVGR provides three(3) output contacts.

One of those are trip contacts to trip a circuit breaker and the others are for alarm signals.

1) Trip contacts

The trip contact is to give a circuit breaker trip signals.

Do not use this contact for the purpose of alarm contact.

Contact rating : 250V AC 10A

2) Alarm contacts

These contacts are to give signals in the events of fault (ALARM1) and self-diagnosis error(ALARM2).

Do not use these contacts for the purpose of trip contact.

Contact rating : 250V AC 5A

3) Terminal Blocks of DPR-511

OVGR			
1	F.G	2	TX0
3	DC +	4	TX1
5	DC -	6	RX0
7		8	RX1
9	GPTk	10	GPTI
11		12	
13		14	
15		16	
17		18	ALARM1
19		20	ALARM1
21	TRIP	22	ALARM2
23	TRIP	24	ALARM2

All terminals of LG DPR series have the same grade of insulation and withstand current properties. Screws and Push-on blade type connectors can be used with them.

4.6 Front face configuration

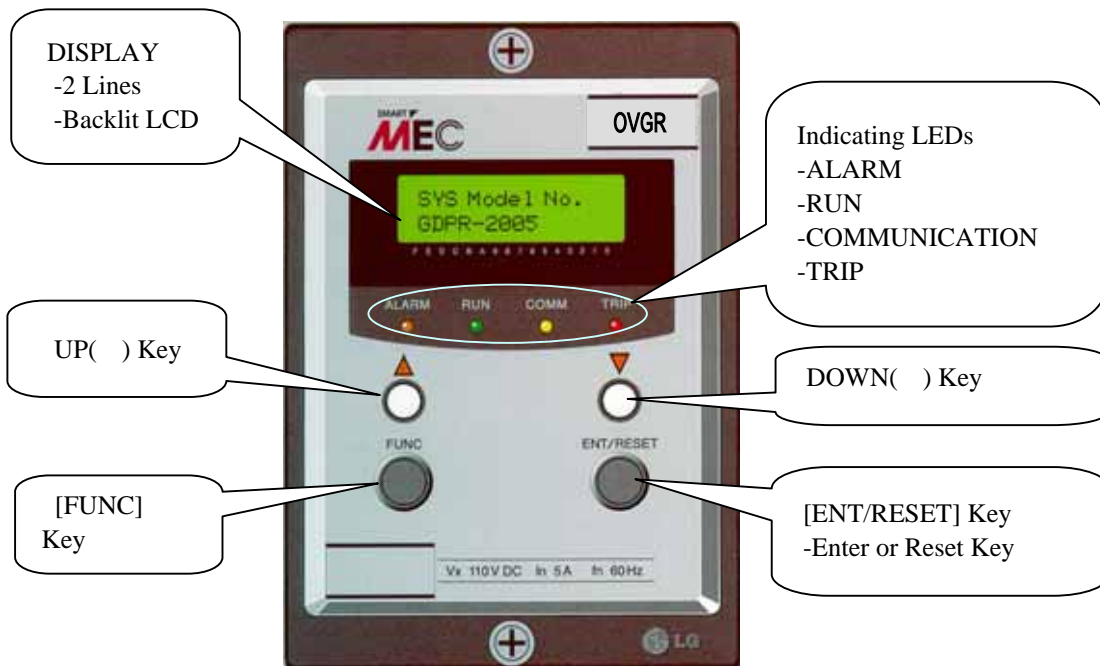

1. [FUNC] Function key to shift between menus
2. [ENT/RESET] Enter or Reset key
 Press to move to a upper or lower menu.
 Press to select the data after changing before saving it.
 In the event of fault it is used to reset.
3. [] Press to increase the value of the data to be changed.
 Press in case of YES to the question asking "Data Save ?"
 Press to shift between upper menus.
- [] Press to decrease the value of the data to be changed.
 Press in case of NO to the question asking "Data Save ?"
 Press to shift between upper menus.
4. [_ F] Keeping pressing the Function key until the initial menu displayed.
 It makes the menu options 00 to return to the initial from any menu.
5. [_ E] Keeping pressing the Enter key to reset in the event of fault.

4.7 Operation manual

- 1) Turn on and then RUN LED lights up and LCD displays as below.
LCD displays [Fig 1-1] for 3 sec and then shows [Fig 1-2].

[Fig. 1-1]

				L		G		I		S				
	D	I	g	I	t	a	I		R	e	I	a	y	

[Fig. 1-2]

	V	o	:			x	.	x	x	x	V			

It is normal running status. The RUN LED keeps lighting up.
X.XXX is the values of zero-phase volts.

- 2) SYS DATA Menu

SYS DATA menu is displayed as shown in Fig 2 by pressing [FUNC] key.

[Fig 2]

1	.	S	Y	S		D	A	T	A					

- 2.1) To move to Password mode as shown in Fig 2-1 press [ENT/RESET] key.

[Fig 2-1]

P	a	s	s	w	o	r	d							
#	#	#	#											

- a) To change any data except Comm Channel(Communication Address) and Comm Baud rate (Communication speed) Password should be inputed.
- b) The factory default set Password is 0123. In case of inputing new Password do not forget it. Contact LG if your Password has been forgotton.
- c) How to input Password 0123

In the Password mode press () key once and then press [ENT/RESET] key.
O is inputed at the first digit as shown in Fig 2-2.

[Fig 2-2]

P	a	s	s	w	o	r	d							
#	#	#	#											



Press () key and [ENT/RESET] key in

P	a	s	s	w	o	r	d							
0	#	#	#											

Press () key once and press [ENT/RESET] key in order.
1 is inputed at the second digit as shown in Fig 2-3.

[Fig 2-3]

P	a	s	s	w	o	r	d										
0	#	#	#														



Press () key and [ENT/RESET] key in

P	a	s	s	w	o	r	d										
0	1	#	#														

Press () key once and press [ENT/RESET] key in order.
2 is inputted at the third digit as shown in Fig 2-4.

[Fig 2-4]

P	a	s	s	w	o	r	d										
0	1	#	#														



Press () key and [ENT/RESET] key in

P	a	s	s	w	o	r	d										
0	1	2	#														

Press () key once and press [ENT/RESET] key in order.
3 is inputted at the last digit as shown in Fig 2-5.

[Fig 2-5]

P	a	s	s	w	o	r	d										
0	1	2	#														



Press () key

P	a	s	s	w	o	r	d										
0	1	2	3														



Press [ENT/RESET] key

	D	a	t	a		S	a	v	e		?						
	Y	e	s	(U	P)		N	o	(D	N)			

* In case of inputting the correct Password
Press () key to the question " Data Save? " and then the RUN LED blinks (flash on and off)
The LCD displays Fig 2-6 and it is allowed to change and save new data.

[Fig 2-6]

P	a	s	s	w	o	r	d										
#	#	#	#														

* In case of inputting the Password incorrectly,
 Press () key to the question " Data Save? " and then the RUN LED lights up (flash on).
 The LCD displays Fig 2-7 and it is not allowed to change any data.

[Fig 2-7]

P	a	s	s	w	o	r	d										
#	#	#	#														

d) How to input New Password

To change Password first input the existing Passord according to the procedure c).
 When the RUN LED blinks input new Password.

2.2) To move to Comm Channel mode as shown in Fig 2-8 press [FUNC] key.
 Communication address can be set here from 1 through 255 by using (), () keys.
 It is required only for communication. Please set 000 in case of no communication.

[Fig 2-8]

C	o	m	m	.		C	h	a	n	n	e	l					
0	0	1															

* Changeable without inputing Password

2.3) To move to Comm Baud rate mode as shown in Fig 2-9 press [FUNC] key.
 Communication speed can be set here among 2400, 4800, 9600 and 19200.

[Fig 2-9]

C	o	m	m	.		B	a	u	d		r	a	t	e			
	9	6	0	0													

* Changeable without inputing Password
 * Factory default set is to 9600.

2.4) Press [FUNC] key to move to Exit mode.

[Fig 2-10]

	E	x	i	t													

To move to 2.SYS info menu press [ENT/RESET] key

3) SYS Info Menu

To move to 2. SYS info menu from 1. SYS DATA menu press [FUNC]

[Fig 3]

2	.	S	Y	S		I	n	f	o								

3.1) DPR-511 (OVGR)

Pressing [ENT/RESET] key, LCD displays the model OVGR as follows.

[Fig. 3-1]

R	e	I	a	y		I	n	f	o						
O	V	G	R												

3.2) Press [FUNC] key and rated zero-phase voltage 190V is displayed.

[Fig. 3-2]

R	a	t	I	n	g		V	o	l	t					
1	9	0		V											

3.3) Pressing [FUNC] key, SYS Model No is displayed as shown in Fig 3-3.

It is not allowed to change Model No.

[Fig. 3-3]

S	Y	S		M	o	d	e	I		N	o	.			
D	P	R	-	5	1	1	S								

3.4) Pressing [FUNC] key, SYS Firmware No. is displayed as shown in Fig 3-4.

It is not allowed to change the Number.

[Fig. 3-4]

S	Y	S		F	I	r	m	w	a	r	e		N	o	.
O	V	G	R	_	V	x	_	x							

* x is Version No. of Firmware assigned by the maker.

3.5) Pressing [FUNC] key, SYS Serial ID with 8 digits is displayed as shown in Fig 3-5.

It is not changeable.

[Fig. 3-5]

S	Y	S		S	e	r	I	a	I		I	D			
S	N	.	x	x	x	x	x	x	x	x					

* x is the No. of manufacture assigned by the maker.

3.6) Pressing [FUNC] key, Comm Module is displayed as shown in Fig 3-6.

It depends on the communication system and is not changeable.(Communication option)

[Fig. 3-6]

C	o	m	m	.	M	o	d	u	l	e					
I	-	N	E	T											

(in case of I-NET)

3.7) Pressing [FUNC] key, Comm Version is displayed as shown in Fig 3-7 which is not changeable.

[Fig. 3-7]

C	o	m	m	.		V	e	r	s	i	o	n				
x	x	x	x													

* x is the version No. of communication module assigned by the maker.

3.8) Press [FUNC] key to move to Exit mode.

[Fig. 3-8]

	E	x	I	t												

To move to 3.FAULT Info menu press [ENT/RESET] key

4) FAULT Info Menu (**unchangeable**)

To move to 3.FAULT Info menu from previous menu press [FUNC]key.

[Fig. 4]

3	.	F	A	U	L	T		I	n	f	o					

4.1) Pressing [ENT/RESET] key, the latest fault value of the zero-phase voltage is displayed as below. It is not changeable.

[Fig. 4-1]

F	a	u	l	t		V	o									
		x	.	x	x	x	V									

* x is fault value.

4.2) Pressing [FUN] key, the fault flag is displayed as below.

Reset to save the present fault data here. It's not allowed to alter the data after saving.

[Fig. 4-2]

Ex.1) When tripped instantly at zero-phase volt 70.9V.

F	a	u	l	t		f	l	a	g	-	1					
		V	>>		:		7	0	.	9	0		V			

Ex.2) In the event of time-delay trip at zero-phase volt 50.9V.

F	a	u	l	t		f	l	a	g	-	1					
		V	>		:		5	0	.	9	0		V			

4.3) Pressing [FUNC] key, Fig 4-3 displays the preceding fault record that is previous to the Fig4-2. It is not changeable.

[Fig. 4-3]

Ex.) When tripped instantly at zero-phase volt 56.9V.

F	a	u	l	t		f	l	a	g	-	2				
			V	>>	:			5	6	.	9	0		V	

4.4) Pressing [FUNC] key, Fig 4-4 displays the preceding fault record that is previous to the Fig4-3. It is not changeable.

[Fig. 4-4]

Ex.) In the event of time-delay trip at zero-phase volt 34.9V.

F	a	u	l	t		f	l	a	g	-	3				
			V	>	:			3	4	.	9	0		V	

4.5) Pressing [FUNC] key, Fig 4-5 displays the preceding fault record that is previous to the Fig4-4. It is not changeable.

[Fig. 4-5]

Ex.) When tripped instantly at zero-phase volt 60.9V.

F	a	u	l	t		f	l	a	g	-	4				
			V	>>	:			6	0	.	9	0		V	

4.6) Press [FUNC] key to move to Fault clear mode.

Here all records in FAULT Info Menu can be cleared by pressing [ENT/RESET] and () keys in order.

[Fig. 4-6]

A	L	L		F	a	u	l	t		C	L	R			
C	L	E	A	R	=			E	N	T		K	e	y	

↓ [ENT/RESET] key

	D	a	t	a		S	a	v	e		?				
	Y	e	s	(U	P)		N	o	(D	N)	

↓ () key

A	L	L		F	a	u	l	t		C	L	R		?	
C	L	E	A	R	=			O	K		!				

4.7) Press [FUNC] key to move Exit mode.

[Fig. 4-7]

	E	x	i	t											

To move to 4.MEASUREMENTS menu press [ENT/RESET] key

5) SGR SETTING Menu (Password protected)

To move to 4.OVGR SETTING menu from previous menu press [FUNC]key.

[Fig. 5]

4	.	O	V	G	R	S	E	T	T	I	N	G		

5.1) Press [ENT/RESET] key and Time-delay Zero-phase voltage SET mode is displayed below. This value can be set here from 20 to 76V at the interval of 2V.

[Fig. 5-1]

	T	D	-	S	E	T								
		7	6	V										

* Use (), () keys to adjust the volt.

Ex.) Changing the zero-phase voltage to 20V from 76V.

V	o	-	S	E	T									
		7	6	V										

() key ↓

V	o	-	S	E	T									
		2	0	V										

[ENT/RESET] key ↓

	D	a	t	a	S	a	v	e	?					
	Y	e	s	(U	P)		N	o	(D	N)

() key ↓

V	o	-	S	E	T									
		2	0	V										

5.2) Press [FUNC] key to move to the TD-Characteristic mode.

4 options of characteristic curves are available here.

[Fig. 5-2]

T	D	-	C	h	a	r	a	c	t	.				
S	t	a	n	d	a	r	d		I	n	v			

standard inverse curve, SI

() key ↓ ↑ () key

T	D	-	C	h	a	r	a	c	t	.				
V	e	r	y		I	n	v							

very inverse curve, VI

() key ↓ ↑ () key

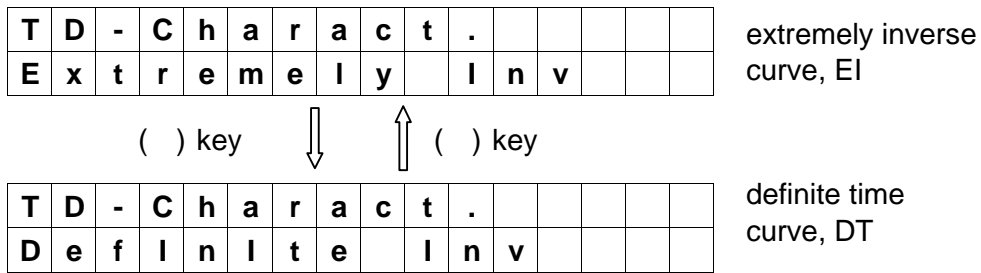

Ex.) Changing the curve to VI(very inverse) from SI(standard inverse)

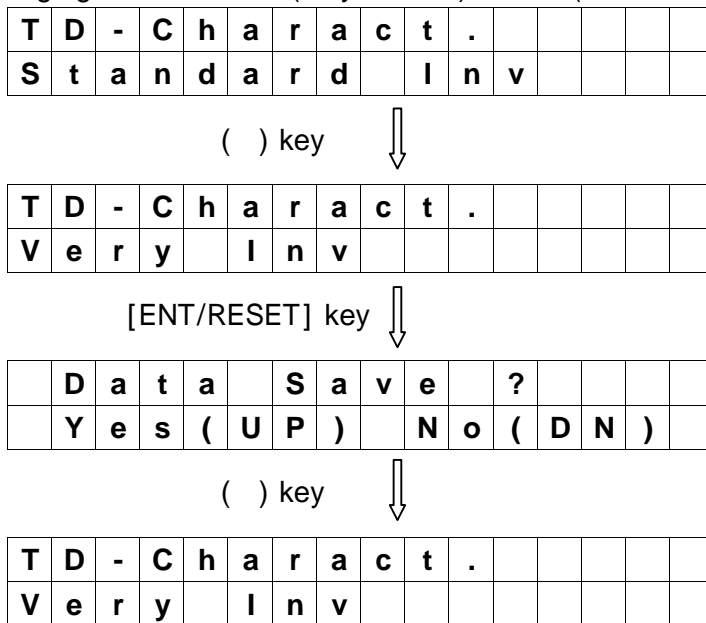

5.3) Press [FUNC] key to move to TD-TimeTap mode.

Delay time can be set here from 0.05 to 1.0 at the interval of 0.01.

[Fig. 5-3]

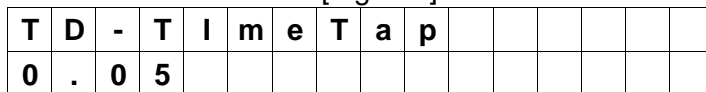

Note : Definite time setting can be done in Definite Inv Mode from 0.1~10sec at the interval of 0.1 sec.

Ex.) Changing delay time to 0.1 from 0.05.

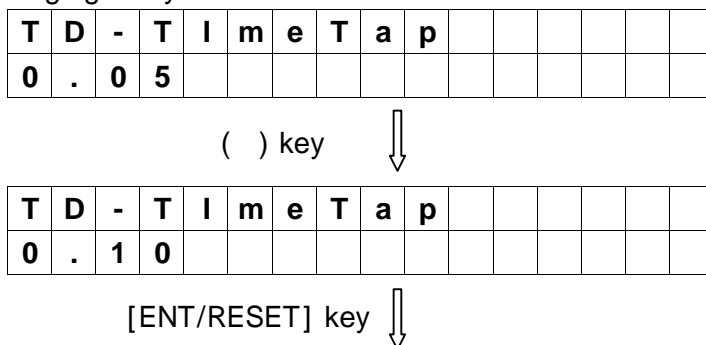

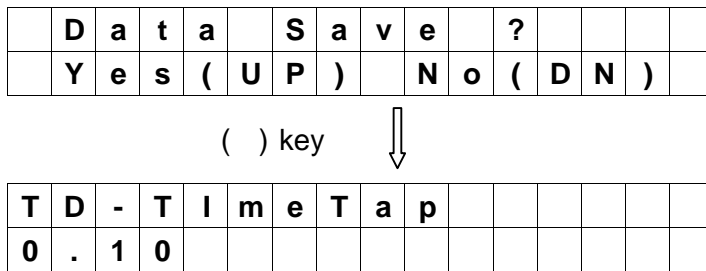

5.4) Press [FUNC] key and Instantaneous-Lock mode is displayed.
 This mode is to select between Lock and UnLock.
 When it is set to Lock the Instantaneous Mode is not displayed.

[Fig. 5-4]

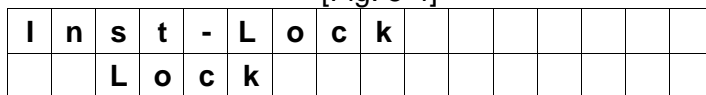

- * If Lock is selected the instantaneous trip is not activated.
- * Press [FUNC] key to move to Exit.

Ex.) Changing of setting to Unlock from Lock.

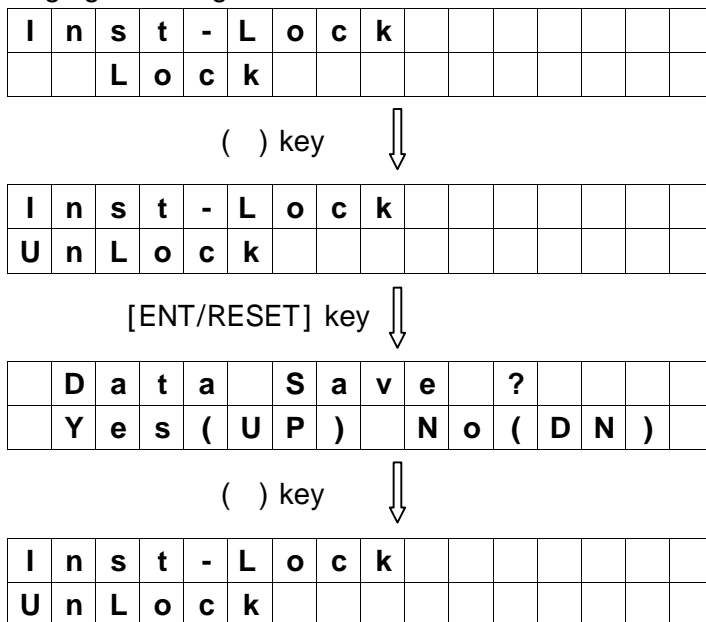

5.5) How to set instantaneous zero-phase volt when the Unlock is selected.
 Instantaneous zero-phase volt can be set from 20 to 76A at the interval of 2V.

[Fig. 5-5]

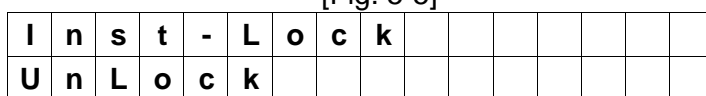

Press [FUNC Button] 5 times ↓

I	N	S	T	-	S	E	T													
	7	6	V																	

Ex.) To set a new data 20V.

I	N	S	T	-	S	E	T													
	7	6	V																	

() key ↓

I	N	S	T	-	S	E	T													
	2	0	V																	

[ENT/RESET] key ↓

	D	a	t	a		S	a	v	e		?									
	Y	e	s	(U	P)		N	o	(D	N)						

() key ↓

I	N	S	T	-	S	E	T													
	2	0	V																	

5.6) How to move to the next mode after inputting the new value 20V.

[Fig. 5-6]

I	N	S	T	-	S	E	T													
	2	0	V																	

[FUNC] key ↓

I	n	s	t	-	L	o	c	k												
U	n	L	o	c	k															

[FUNC] key ↓

	E	x	I	t																

5.7) Press [ENT/REST] key at this mode to move to DO SETTING menu.

6) Press [FUNC] key to move to 5.DO SETTING menu.

[Fig. 6]

5	.		D	O		S	E	T	T	I	N	G				

6.1) Pressing [ENT/RESET] key, the present Relay output status are displayed as below.

[Fig. 6-1]

D	O		S	t	a	t	u	s								
0	0	0														

* 3 digits represent 3 output relays and each digit shows the status of the corresponding Relay output. 0 indicates Relay off and 1 indicates On status.

Ex.) Chart below indicates only the 2nd Relay is on status.

D	O		S	t	a	t	u	s								
0	1	0														

* It is not latched but depends on the user's DO SETTING.

6.2) Output contacts configuration

The output contacts are fixed as shown in Fig 6-2.

[Fig. 6-2]

Setting \ Contact		For ALARM			Use of contacts
		For TRIP	ALARM1	ALARM2	
TRIP RELAY	TRIP		X	X	TRIP
ALARM RELAY	ALM-TRIP	X		X	Alarm TRIP
	ALM-Sys Fail	X	X		Self-diagnosis

Note 1 : Factory set User set. If necessary. X : Not available

Note 2 : Do not use a ALARM Relay instead of TRIP(CB CONTOL) contacts.

Note 3 : If TRIP conatct is operated, the both status before and after event are stored.

6.3) Press [FUNC] key to move to the mode to set the function of TRIP Relay.

[Fig. 6-3]

T	R	I	P	-	S	E	T									
T	R	I	P													

6.4) Press [FUNC] key to move to the mode to set the function of ALARM1 Relay.

[Fig. 6-4]

A	L	A	R	M	1	-	S	E	T							
A	L	M	-	T	R	I	P									

6.5) Press [FUNC] key to move to the mode to set the function of ALARM2 Relay.

[Fig. 6-5]

A	L	A	R	M	1	-	S	E	T						
A	L	M	-	S	y	s	F	a	I	I					

6.6) Pressing [FUNC] key, Fig 6-6 displays. Press [ENT/RESET] key to move MENU Exit.

[Fig. 6-6]

	E	x	I	t											

7) DATA displayed in the event of fault

When fault happens TRIP LED lights up and LCD Backlit and RUN LED are blinking. LCD displays the status as follows.

[Fig. 7]

Ex.1) In the event of instant trip at Zero-phase voltage 27.34V.

	□		F	a	u	I	t		T	r	i	p		□	
			V	>>	:				2	7	.	3	4		V

Ex.2) In the event of time-delay trip at Zero-phase voltage 30.50V.

	□		F	a	u	I	t		T	r	i	p		□	
			V	>	:				3	0	.	5	0		V

8) DATA displayed in the event of Self-diagnosis Error

Error signal is as shown in Fig 10.

[Fig. 8]

S	Y	S		S	t	a	t	u	s						
E	R	R	0	R		x									

* In the event of happening more than one Error at the same time all Error codes are displayed. (Ex. ERROR 124)

5. Characteristic curves and data

5.1 Data on Standard Inverse Time Delay Curve

$$t = \frac{0.14}{G^{0.02} - 1} \times T_{lever} \text{ (sec)}$$

T_{lever} = time lever

G = I(operating current) / Is(set current)

T _{lever} Time lever	Trip Time (sec)		
	200%	700%	2000%
0.05	0.501	0.176	0.113
0.06	0.602	0.212	0.136
0.07	0.702	0.247	0.159
0.08	0.802	0.282	0.181
0.09	0.903	0.317	0.204
0.1	1.003	0.353	0.227
0.11	1.103	0.388	0.249
0.12	1.203	0.423	0.272
0.13	1.304	0.459	0.295
0.14	1.404	0.494	0.317
0.15	1.504	0.529	0.340
0.16	1.605	0.564	0.363
0.17	1.705	0.600	0.385
0.18	1.805	0.635	0.408
0.19	1.906	0.670	0.431
0.2	2.006	0.706	0.453
0.21	2.106	0.741	0.476
0.22	2.206	0.776	0.499
0.23	2.307	0.811	0.521
0.24	2.407	0.847	0.544
0.25	2.507	0.882	0.567
0.26	2.608	0.917	0.590
0.27	2.708	0.952	0.612
0.28	2.808	0.988	0.635
0.29	2.908	1.023	0.658
0.3	3.009	1.058	0.680
0.31	3.109	1.094	0.703
0.32	3.209	1.129	0.726
0.33	3.310	1.164	0.748
0.34	3.410	1.199	0.771
0.35	3.510	1.235	0.794
0.36	3.610	1.270	0.816
0.37	3.711	1.305	0.839
0.38	3.811	1.341	0.862
0.39	3.911	1.376	0.884
0.4	4.012	1.411	0.907
0.41	4.112	1.446	0.930
0.42	4.212	1.482	0.952
0.43	4.312	1.517	0.975
0.44	4.413	1.552	0.998
0.45	4.513	1.587	1.020
0.46	4.613	1.623	1.043
0.47	4.714	1.658	1.066
0.48	4.814	1.693	1.088
0.49	4.914	1.729	1.111
0.5	5.015	1.764	1.134
0.51	5.115	1.799	1.156
0.52	5.215	1.834	1.179

T _{lever} Time lever	Trip Time (sec)		
	200%	700%	2000%
0.53	5.315	1.870	1.202
0.54	5.416	1.905	1.224
0.55	5.516	1.940	1.247
0.56	5.616	1.976	1.270
0.57	5.717	2.011	1.292
0.58	5.817	2.046	1.315
0.59	5.917	2.081	1.338
0.6	6.017	2.117	1.360
0.61	6.118	2.152	1.383
0.62	6.218	2.187	1.406
0.63	6.318	2.222	1.428
0.64	6.419	2.258	1.451
0.65	6.519	2.293	1.474
0.66	6.619	2.328	1.496
0.67	6.719	2.364	1.519
0.68	6.820	2.399	1.542
0.69	6.920	2.434	1.564
0.7	7.020	2.469	1.587
0.71	7.121	2.505	1.610
0.72	7.221	2.540	1.632
0.73	7.321	2.575	1.655
0.74	7.421	2.611	1.678
0.75	7.522	2.646	1.701
0.76	7.622	2.681	1.723
0.77	7.722	2.716	1.746
0.78	7.823	2.752	1.769
0.79	7.923	2.787	1.791
0.8	8.023	2.822	1.814
0.81	8.124	2.857	1.837
0.82	8.224	2.893	1.859
0.83	8.324	2.928	1.882
0.84	8.424	2.963	1.905
0.85	8.525	2.999	1.927
0.86	8.625	3.034	1.950
0.87	8.725	3.069	1.973
0.88	8.826	3.104	1.995
0.89	8.926	3.140	2.018
0.9	9.026	3.175	2.041
0.91	9.126	3.210	2.063
0.92	9.227	3.246	2.086
0.93	9.327	3.281	2.109
0.94	9.427	3.316	2.131
0.95	9.528	3.351	2.154
0.96	9.628	3.387	2.177
0.97	9.728	3.422	2.199
0.98	9.828	3.457	2.222
0.99	9.929	3.492	2.245
1	10.029	3.528	2.267

5.2 Standard Inverse Time Delay Curve

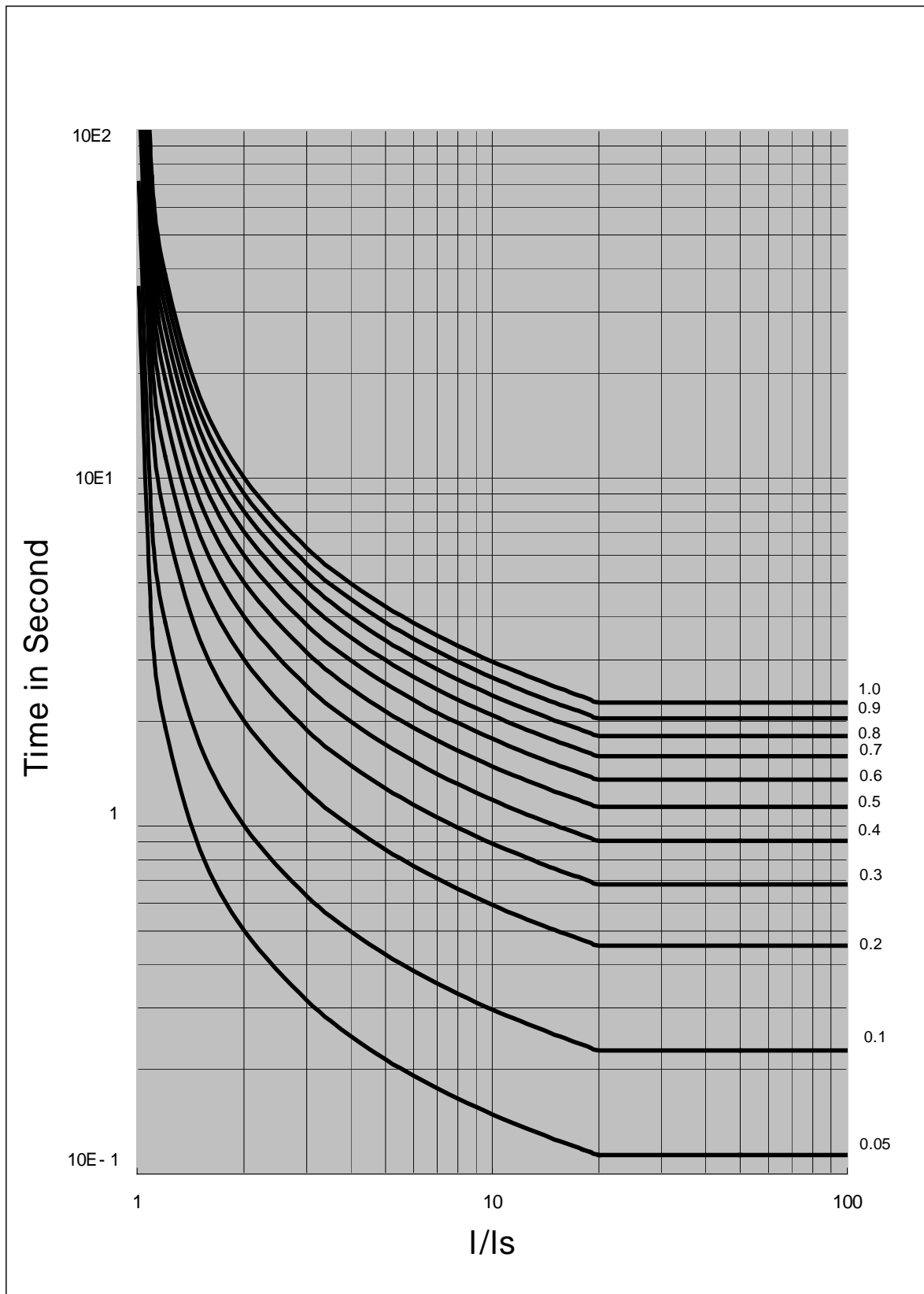

5.3 Data on Very Inverse Time Delay Curve

$$t = \frac{13.5}{G - 1} \times T_{lever} \text{ (sec)}$$

T_{lever} = time lever

G = I(operating current) / I_s(set current)

T _{lever}	Trip Time (sec)		
	200%	700%	2000%
0.05	0.675	0.113	0.036
0.06	0.810	0.135	0.043
0.07	0.945	0.158	0.050
0.08	1.080	0.180	0.057
0.09	1.215	0.203	0.064
0.1	1.350	0.225	0.071
0.11	1.485	0.248	0.078
0.12	1.620	0.270	0.085
0.13	1.755	0.293	0.092
0.14	1.890	0.315	0.099
0.15	2.025	0.338	0.107
0.16	2.160	0.360	0.114
0.17	2.295	0.383	0.121
0.18	2.430	0.405	0.128
0.19	2.565	0.428	0.135
0.2	2.700	0.450	0.142
0.21	2.835	0.473	0.149
0.22	2.970	0.495	0.156
0.23	3.105	0.518	0.163
0.24	3.240	0.540	0.171
0.25	3.375	0.563	0.178
0.26	3.510	0.585	0.185
0.27	3.645	0.608	0.192
0.28	3.780	0.630	0.199
0.29	3.915	0.653	0.206
0.3	4.050	0.675	0.213
0.31	4.185	0.698	0.220
0.32	4.320	0.720	0.227
0.33	4.455	0.743	0.234
0.34	4.590	0.765	0.242
0.35	4.725	0.788	0.249
0.36	4.860	0.810	0.256
0.37	4.995	0.833	0.263
0.38	5.130	0.855	0.270
0.39	5.265	0.878	0.277
0.4	5.400	0.900	0.284
0.41	5.535	0.923	0.291
0.42	5.670	0.945	0.298
0.43	5.805	0.968	0.306
0.44	5.940	0.990	0.313
0.45	6.075	1.013	0.320
0.46	6.210	1.035	0.327
0.47	6.345	1.058	0.334
0.48	6.480	1.080	0.341
0.49	6.615	1.103	0.348
0.5	6.750	1.125	0.355
0.51	6.885	1.148	0.362
0.52	7.020	1.170	0.369

T _{lever}	Trip Time (sec)		
	200%	700%	2000%
0.53	7.155	1.193	0.377
0.54	7.290	1.215	0.384
0.55	7.425	1.238	0.391
0.56	7.560	1.260	0.398
0.57	7.695	1.283	0.405
0.58	7.830	1.305	0.412
0.59	7.965	1.328	0.419
0.6	8.100	1.350	0.426
0.61	8.235	1.373	0.433
0.62	8.370	1.395	0.441
0.63	8.505	1.418	0.448
0.64	8.640	1.440	0.455
0.65	8.775	1.463	0.462
0.66	8.910	1.485	0.469
0.67	9.045	1.508	0.476
0.68	9.180	1.530	0.483
0.69	9.315	1.553	0.490
0.7	9.450	1.575	0.497
0.71	9.585	1.598	0.504
0.72	9.720	1.620	0.512
0.73	9.855	1.643	0.519
0.74	9.990	1.665	0.526
0.75	10.125	1.688	0.533
0.76	10.260	1.710	0.540
0.77	10.395	1.733	0.547
0.78	10.530	1.755	0.554
0.79	10.665	1.778	0.561
0.8	10.800	1.800	0.568
0.81	10.935	1.823	0.576
0.82	11.070	1.845	0.583
0.83	11.205	1.868	0.590
0.84	11.340	1.890	0.597
0.85	11.475	1.913	0.604
0.86	11.610	1.935	0.611
0.87	11.745	1.958	0.618
0.88	11.880	1.980	0.625
0.89	12.015	2.003	0.632
0.9	12.150	2.025	0.639
0.91	12.285	2.048	0.647
0.92	12.420	2.070	0.654
0.93	12.555	2.093	0.661
0.94	12.690	2.115	0.668
0.95	12.825	2.138	0.675
0.96	12.960	2.160	0.682
0.97	13.095	2.183	0.689
0.98	13.230	2.205	0.696
0.99	13.365	2.228	0.703
1	13.500	2.250	0.711

5.4 Very Inverse Time Delay Curve

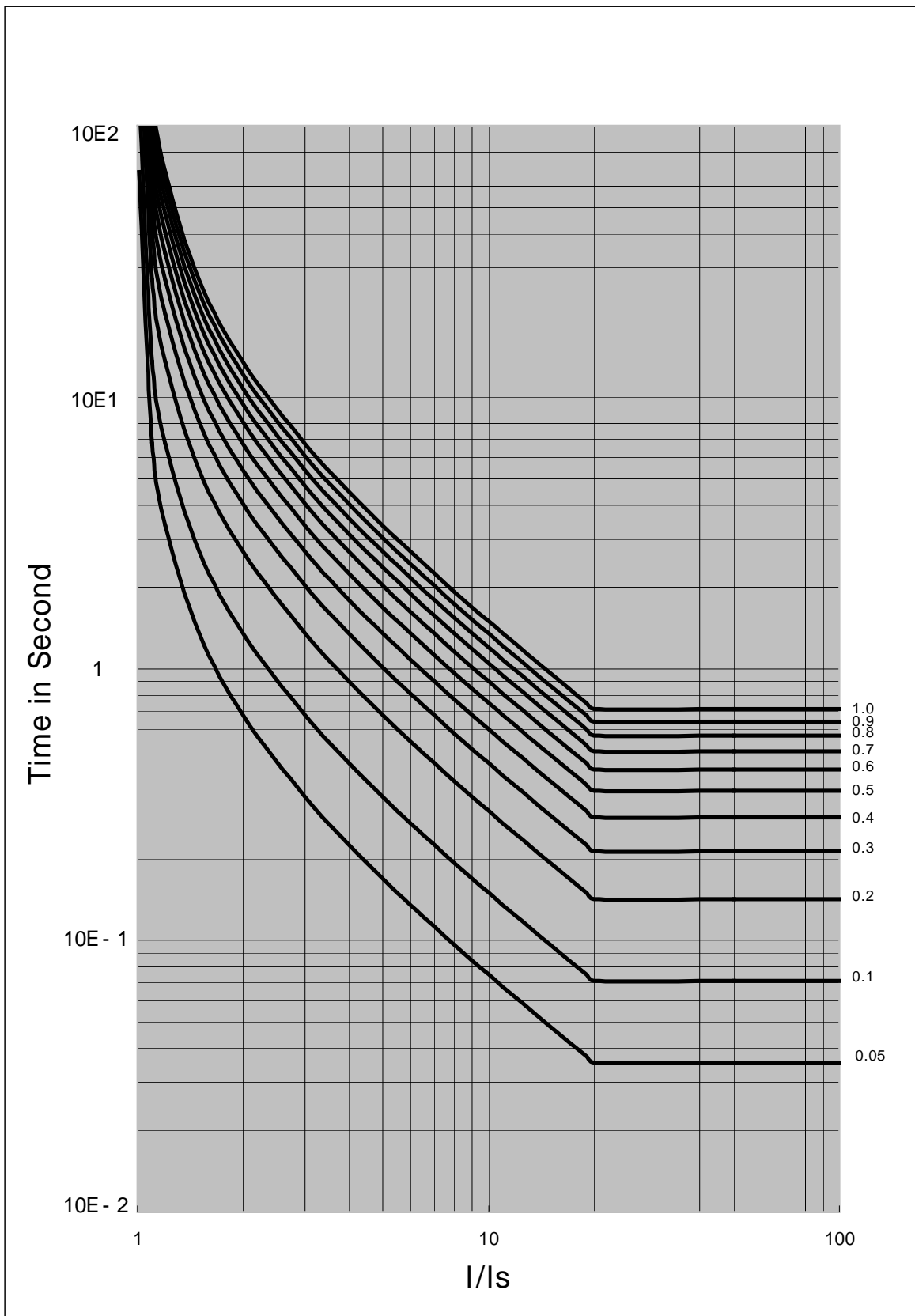

5.5 Data on Extremely Inverse Time Delay Curve

$$t = \frac{80}{G^2 - 1} \times T_{lever} \text{ (sec)}$$

T_{lever} = time lever

G = I(operating current) / I_s(set current)

T _{lever} Time lever	Trip Time (sec)		
	200%	700%	2000%
0.05	1.333	0.083	0.035
0.06	1.600	0.100	0.035
0.07	1.867	0.117	0.035
0.08	2.133	0.133	0.035
0.09	2.400	0.150	0.035
0.1	2.667	0.167	0.035
0.11	2.933	0.183	0.035
0.12	3.200	0.200	0.035
0.13	3.467	0.217	0.035
0.14	3.733	0.233	0.035
0.15	4.000	0.250	0.035
0.16	4.267	0.267	0.035
0.17	4.533	0.283	0.035
0.18	4.800	0.300	0.036
0.19	5.067	0.317	0.038
0.2	5.333	0.333	0.040
0.21	5.600	0.350	0.042
0.22	5.867	0.367	0.044
0.23	6.133	0.383	0.046
0.24	6.400	0.400	0.048
0.25	6.667	0.417	0.050
0.26	6.933	0.433	0.052
0.27	7.200	0.450	0.054
0.28	7.467	0.467	0.056
0.29	7.733	0.483	0.058
0.3	8.000	0.500	0.060
0.31	8.267	0.517	0.062
0.32	8.533	0.533	0.064
0.33	8.800	0.550	0.066
0.34	9.067	0.567	0.068
0.35	9.333	0.583	0.070
0.36	9.600	0.600	0.072
0.37	9.867	0.617	0.074
0.38	10.133	0.633	0.076
0.39	10.400	0.650	0.078
0.4	10.667	0.667	0.080
0.41	10.933	0.683	0.082
0.42	11.200	0.700	0.084
0.43	11.467	0.717	0.086
0.44	11.733	0.733	0.088
0.45	12.000	0.750	0.090
0.46	12.267	0.767	0.092
0.47	12.533	0.783	0.094
0.48	12.800	0.800	0.096
0.49	13.067	0.817	0.098
0.5	13.333	0.833	0.100
0.51	13.600	0.850	0.102
0.52	13.867	0.867	0.104

T _{lever} Time lever	Trip Time (sec)		
	200%	700%	2000%
0.53	14.133	0.883	0.106
0.54	14.400	0.900	0.108
0.55	14.667	0.917	0.110
0.56	14.933	0.933	0.112
0.57	15.200	0.950	0.114
0.58	15.467	0.967	0.116
0.59	15.733	0.983	0.118
0.6	16.000	1.000	0.120
0.61	16.267	1.017	0.122
0.62	16.533	1.033	0.124
0.63	16.800	1.050	0.126
0.64	17.067	1.067	0.128
0.65	17.333	1.083	0.130
0.66	17.600	1.100	0.132
0.67	17.867	1.117	0.134
0.68	18.133	1.133	0.136
0.69	18.400	1.150	0.138
0.7	18.667	1.167	0.140
0.71	18.933	1.183	0.142
0.72	19.200	1.200	0.144
0.73	19.467	1.217	0.146
0.74	19.733	1.233	0.148
0.75	20.000	1.250	0.150
0.76	20.267	1.267	0.152
0.77	20.533	1.283	0.154
0.78	20.800	1.300	0.156
0.79	21.067	1.317	0.158
0.8	21.333	1.333	0.160
0.81	21.600	1.350	0.162
0.82	21.867	1.367	0.164
0.83	22.133	1.383	0.166
0.84	22.400	1.400	0.168
0.85	22.667	1.417	0.170
0.86	22.933	1.433	0.172
0.87	23.200	1.450	0.174
0.88	23.467	1.467	0.176
0.89	23.733	1.483	0.178
0.9	24.000	1.500	0.180
0.91	24.267	1.517	0.182
0.92	24.533	1.533	0.184
0.93	24.800	1.550	0.186
0.94	25.067	1.567	0.188
0.95	25.333	1.583	0.190
0.96	25.600	1.600	0.192
0.97	25.867	1.617	0.194
0.98	26.133	1.633	0.196
0.99	26.400	1.650	0.198
1	26.667	1.667	0.201

5.6 Extremely Inverse Time Delay Curve

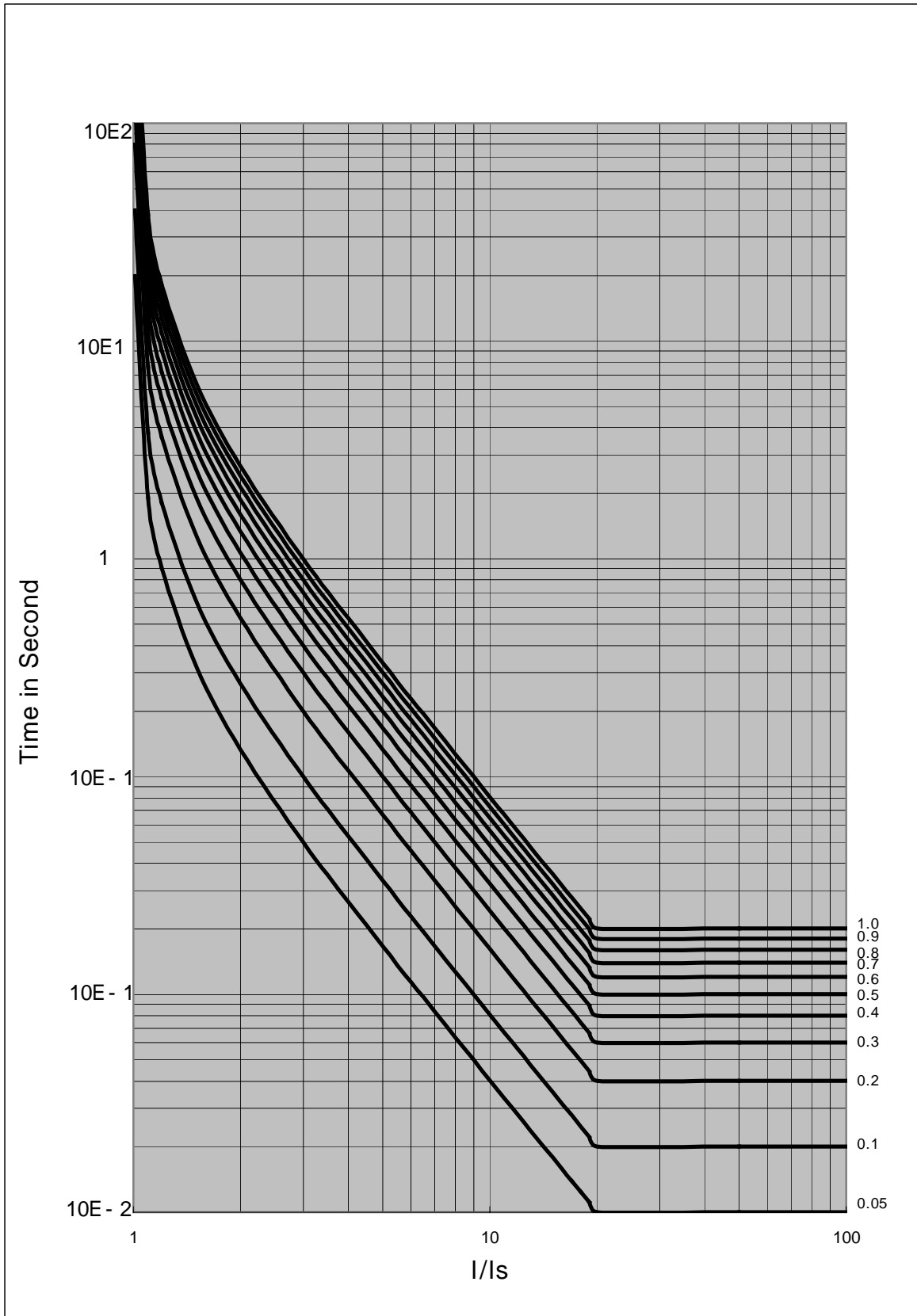

5.7 Data on Long Inverse Time Delay Curve

$$t = \frac{120}{G - 1} \times T_{lever} \text{ (sec)}$$

T_{lever} = time lever

G = I(operating current) / I_s(set current)

T _{lever}	Trip Time (sec)		
Time lever	200%	700%	2000%
0.05	6.000	1.000	0.316
0.06	7.200	1.200	0.379
0.07	8.400	1.400	0.442
0.08	9.600	1.600	0.505
0.09	10.800	1.800	0.568
0.1	12.000	2.000	0.632
0.11	13.200	2.200	0.695
0.12	14.400	2.400	0.758
0.13	15.600	2.600	0.821
0.14	16.800	2.800	0.884
0.15	18.000	3.000	0.947
0.16	19.200	3.200	1.011
0.17	20.400	3.400	1.074
0.18	21.600	3.600	1.137
0.19	22.800	3.800	1.200
0.2	24.000	4.000	1.263
0.21	25.200	4.200	1.326
0.22	26.400	4.400	1.389
0.23	27.600	4.600	1.453
0.24	28.800	4.800	1.516
0.25	30.000	5.000	1.579
0.26	31.200	5.200	1.642
0.27	32.400	5.400	1.705
0.28	33.600	5.600	1.768
0.29	34.800	5.800	1.832
0.3	36.000	6.000	1.895
0.31	37.200	6.200	1.958
0.32	38.400	6.400	2.021
0.33	39.600	6.600	2.084
0.34	40.800	6.800	2.147
0.35	42.000	7.000	2.211
0.36	43.200	7.200	2.274
0.37	44.400	7.400	2.337
0.38	45.600	7.600	2.400
0.39	46.800	7.800	2.463
0.4	48.000	8.000	2.526
0.41	49.200	8.200	2.589
0.42	50.400	8.400	2.653
0.43	51.600	8.600	2.716
0.44	52.800	8.800	2.779
0.45	54.000	9.000	2.842
0.46	55.200	9.200	2.905
0.47	56.400	9.400	2.968
0.48	57.600	9.600	3.032
0.49	58.800	9.800	3.095
0.5	60.000	10.000	3.158
0.51	61.200	10.200	3.221
0.52	62.400	10.400	3.284

T _{lever}	Trip Time (sec)		
Time lever	200%	700%	2000%
0.53	63.600	10.600	3.347
0.54	64.800	10.800	3.411
0.55	66.000	11.000	3.474
0.56	67.200	11.200	3.537
0.57	68.400	11.400	3.600
0.58	69.600	11.600	3.663
0.59	70.800	11.800	3.726
0.6	72.000	12.000	3.789
0.61	73.200	12.200	3.853
0.62	74.400	12.400	3.916
0.63	75.600	12.600	3.979
0.64	76.800	12.800	4.042
0.65	78.000	13.000	4.105
0.66	79.200	13.200	4.168
0.67	80.400	13.400	4.232
0.68	81.600	13.600	4.295
0.69	82.800	13.800	4.358
0.7	84.000	14.000	4.421
0.71	85.200	14.200	4.484
0.72	86.400	14.400	4.547
0.73	87.600	14.600	4.611
0.74	88.800	14.800	4.674
0.75	90.000	15.000	4.737
0.76	91.200	15.200	4.800
0.77	92.400	15.400	4.863
0.78	93.600	15.600	4.926
0.79	94.800	15.800	4.989
0.8	96.000	16.000	5.053
0.81	97.200	16.200	5.116
0.82	98.400	16.400	5.179
0.83	99.600	16.600	5.242
0.84	100.800	16.800	5.305
0.85	102.000	17.000	5.368
0.86	103.200	17.200	5.432
0.87	104.400	17.400	5.495
0.88	105.600	17.600	5.558
0.89	106.800	17.800	5.621
0.9	108.000	18.000	5.684
0.91	109.200	18.200	5.747
0.92	110.400	18.400	5.811
0.93	111.600	18.600	5.874
0.94	112.800	18.800	5.937
0.95	114.000	19.000	6.000
0.96	115.200	19.200	6.063
0.97	116.400	19.400	6.126
0.98	117.600	19.600	6.189
0.99	118.800	19.800	6.253
1	120.000	20.000	6.316

5.8 Data on Long Inverse Time Delay Curve

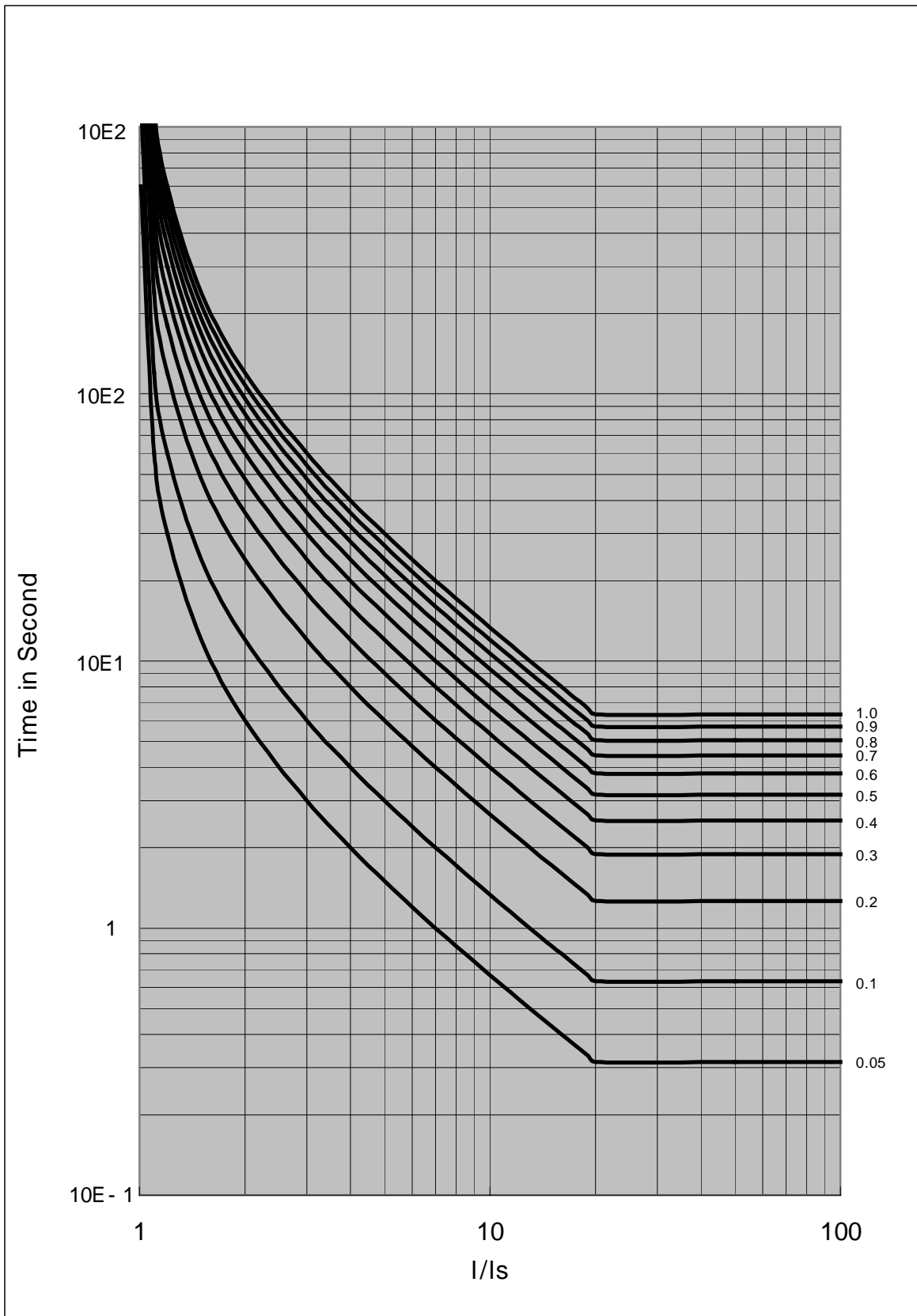

6. Dimensions and Installation

6.1 Dimensions, mm

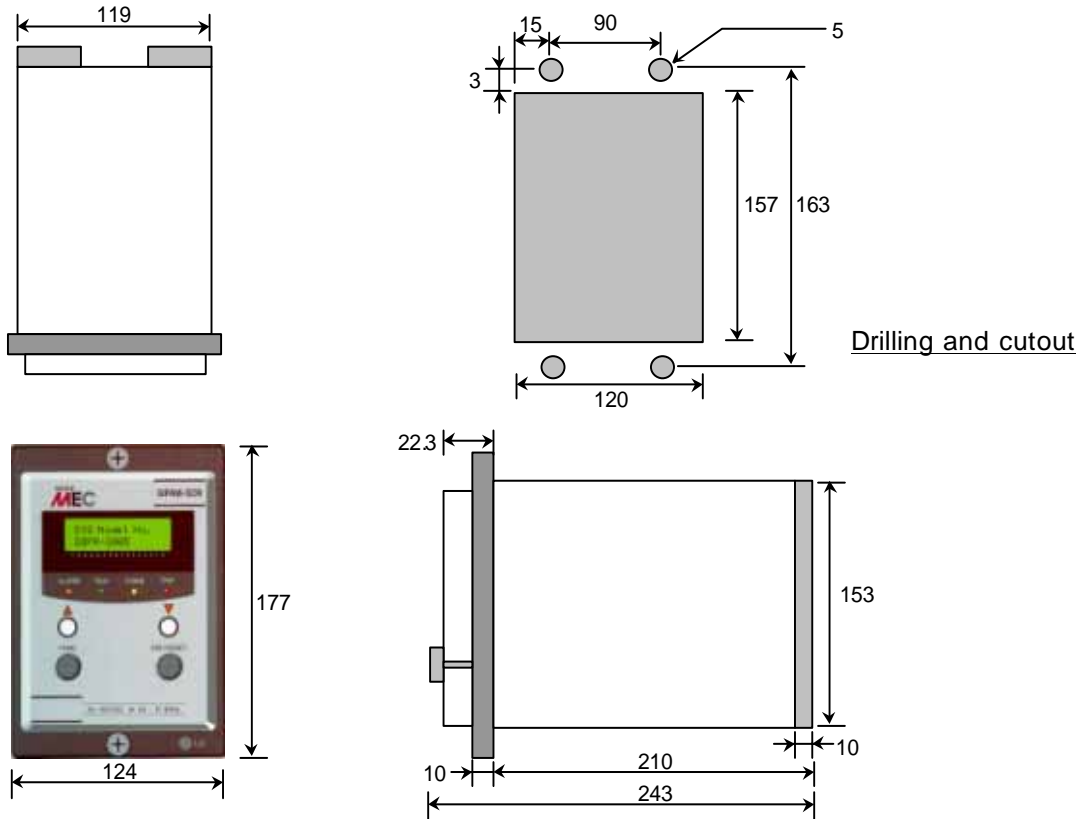

6.2 Installation

Insert a DPR into the panel cutout and fix it with 4 ea of bolts.
Two types of connection, screw or fast-on connector are available.

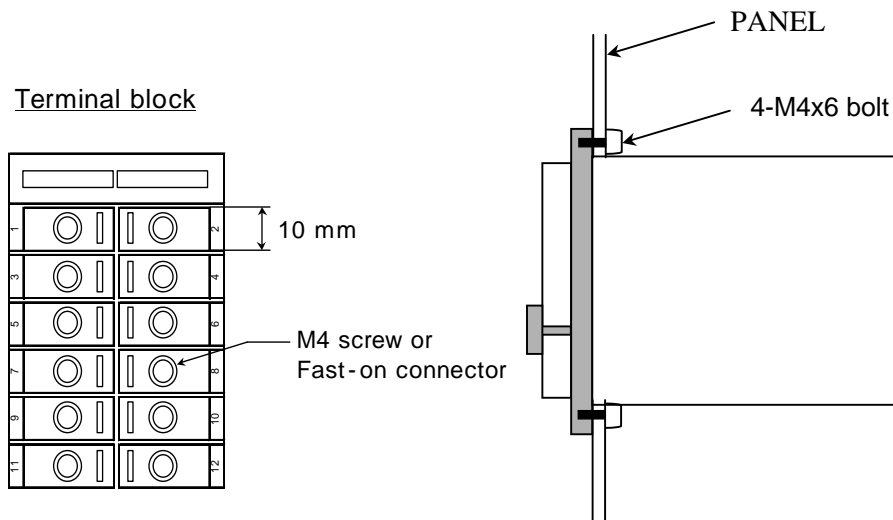

7. Warnings

(1) Check points before power supply

- Verify that the earth terminal is connected properly.
- Check the control voltage, DC110V and polarity.
- Verify that wirings for output contacts are right.
- Verify that input wirings for current and voltage are right.

(2) Keep the LCD parts out of the direct rays of the sun.

(3) Keep the DPR case handling horizontally when inserting and drawing out.
If not, the terminals in it may be damaged.

8. Ordering information

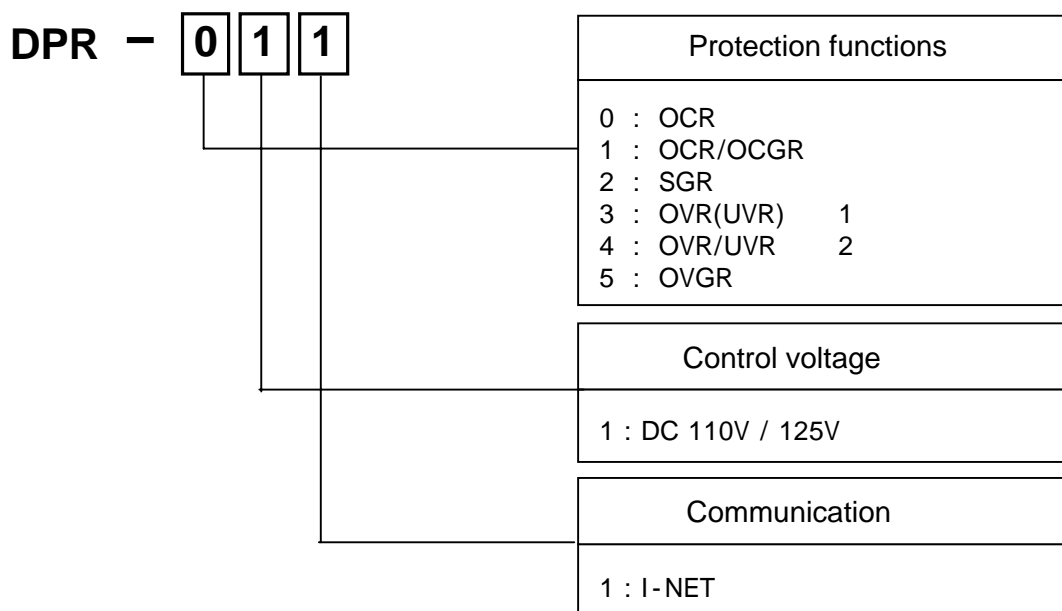

Note 1 : OVR(UVR) : One between OVR and UVR should be selected when setting.
 2 : OVR/UVR : Both functions of OVR and UVR are available at the same time in



LG Industrial Systems

■ HEAD OFFICE

LG TWIN TOWERS, 20 Yoido-dong, Youngdungpo-gu,
Seoul, 150-721, Korea
Tel. (82-2)3777-4870
Fax. (82-2)3777-4713
<http://www.lgis.com>

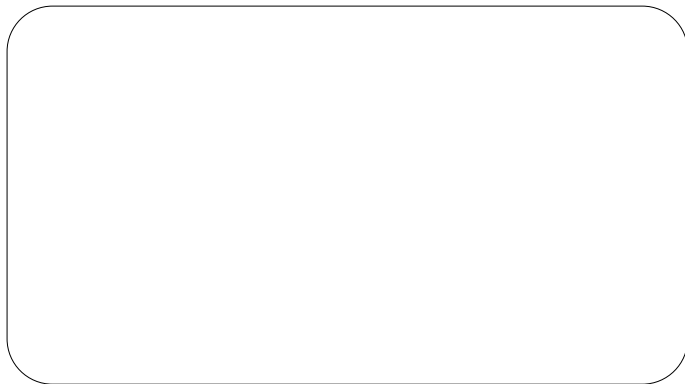

LG constantly endeavor to improve our products
so that information in this catalog is subject to change without notice.

Global network

■ Dalian LG Industrial Systems Co.,Ltd China

● Address : No. 15 Liaohexi 3 Road, economic and
technical development zone, Dalian, China
● Tel : 86-411-731-8210 ● Fax : 86-411-730-7560
● e-mail : youngeel@lgis.com

■ LG-VINA Industrial Systems Co.,Ltd Vietnam

● Address : LGIS VINA Congty che tao may dien Viet-Hung Dong Anh
Hanoi, Vietnam
● Tel : 84-4-882-0222 ● Fax : 84-4-882-0220
● e-mail : srjo@hn.vnn.vn

■ LG Industrial Trading (Shanghai) Co.,Ltd China

● Address : Room1705-1707, 17th Floor Xinda
Commerical Building No 318, Xian Xia Road Shanahai
● Tel : 86-21-6252-4291 ● Fax : 86-21-6278-4372
● e-mail : jkkimb@lgis.com

■ LG Industrial Systems Beijing Office China

● Address : Room 303, 3F North B/D, EAS 21 XIAO YUN ROAD,
Dong San Huan Bei Road, Chao Yang District, Beijing, China
● Tel : 86-10-6462-3259/4 ● Fax : 86-10-6462-3236
● e-mail : sclim@mx.cei.gov.cn

■ LG Industrial Systems Shanghai Office China

● Address : Room1705-1707, 17th Floor Xinda Commerical Building
No 318, Xian Xia Road Shanahai, China
● Tel : 86-21-6278-4370 ● Fax : 86-21-6278-4301
● e-mail : sdkwang@lgis.com

■ LG Industrial Systems Guangzhou Office China

● Address : Room 303, 3F, Zheng Sheng Building, No 5-6, Tian He
Bei Road, Guangzhou, China
● Tel : 86-20-8755-3410 ● Fax : 86-20-8755-3408
● e-mail : lgisgz@public1.guangzhou.gd.cn

■ LG Industrial Systems New Jersey Office USA

● Address : 1000 Sylvan Avenue, Englewood Cliffs, New Jersey 07632 USA
● Tel : 1-201-816-2985 ● Fax : 1-201-816-2343
● e-mail : hskim@lgisusa.com

■ LG Industrial Systems Tokyo Office Japan

● Address : 16F, Higashi-Kan, Akasaka Twin Towers 17-22, 2-chome,
Akasaka, Minato-ku Tokyo 107-0052, Japan
● Tel : 81-3-3582-9126 ● Fax : 81-3-3582-0062
● e-mail : snbaek@partner.lgis.co.jp